

Архангельск (8182)63-90-72
Астана (7172)727-132
Астрахань (8512)99-46-04
Барнаул (3852)73-04-60
Белгород (4722)40-23-64
Брянск (4832)59-03-52
Владивосток (423)249-28-31
Волгоград (844)278-03-48
Вологда (8172)26-41-59
Воронеж (473)204-51-73
Екатеринбург (343)384-55-89
Иваново (4932)77-34-06

Ижевск (3412)26-03-58
Иркутск (395)279-98-46
Казань (843)206-01-48
Калининград (4012)72-03-81
Калуга (4842)92-23-67
Кемерово (3842)65-04-62
Киров (8332)68-02-04
Краснодар (861)203-40-90
Красноярск (391)204-63-61
Курск (4712)77-13-04
Липецк (4742)52-20-81

Киргизия (996)312-96-26-47

Магнитогорск (3519)55-03-13
Москва (495)268-04-70
Мурманск (8152)59-64-93
Набережные Челны (8552)20-53-41
Нижний Новгород (831)429-08-12
Новокузнецк (3843)20-46-81
Новосибирск (383)227-86-73
Омск (3812)21-46-40
Орел (4862)44-53-42
Оренбург (3532)37-68-04
Пенза (8412)22-31-16

Россия (495)268-04-70

Пермь (342)205-81-47
Ростов-на-Дону (863)308-18-15
Рязань (4912)46-61-64
Самара (846)206-03-16
Санкт-Петербург (812)309-46-40
Саратов (845)249-38-78
Севастополь (8692)22-31-93
Симферополь (3652)67-13-56
Смоленск (4812)29-41-54
Сочи (862)225-72-31
Ставрополь (8652)20-65-13

Казахстан (772)734-952-31

Сургут (3462)77-98-35
Тверь (4822)63-31-35
Томск (3822)98-41-53
Тула (4872)74-02-29
Тюмень (3452)66-21-18
Ульяновск (8422)24-23-59
Уфа (347)229-48-12
Хабаровск (4212)92-98-04
Челябинск (351)202-03-61
Череповец (8202)49-02-64
Ярославль (4852)69-52-93

<https://siruba.nt-rt.ru> || sbe@nt-rt.ru

КАТАЛОГ





製衣工程

APPLICATION

▶ PAGE

1



自動化

AUTOMATIC SEWING

▶ PAGE

13

ASP-EBJ Series , ASV-ATS100A , ASK-ACS100 , ASK-ASM100 ,
ASK-ASM200 , ASC-TBH100 , ASP-SFS Series , ASP-PTA Series ,
ASP- ABF100



包縫機

OVERLOCK STITCH MACHINE

▶ PAGE

33

700L , 700LX , 700KS , 700KST , 700KT , 700K



繃縫機

INTERLOCK STITCH MACHINE

▶ PAGE

73

C007L , C007LX , C007K , U007 , C007JP , S007K , F007K



多針鏈縫機

MULTI-NEEDLE/PICOTING CHAINSTITCH MACHINE

▶ PAGE

129

NC008 , VC008 , VC008A , VC008B , HF008A , Z008



平縫機

LOCKSTITCH MACHINE

▶ PAGE

180

DL7200B , DL7400 , DL720 , DL7200 , DL7300 , T8200 , DT8200



電子花樣機/鎖眼機/套結機/釘扣機

COMPUTER-CONTROLLED CYCLE MACHINE

▶ PAGE

192

PS Series , BT Series , BH9820 Series , LBHS1790 ,
LKS1900AN SERIES , LKS1900P



四針六線併縫機

4-NEEDLE 6-THREAD FLATSEAMER

▶ PAGE

223

D007SB , D007S , D007RB , D007R

其他

OTHER

▶ PAGE

232

BH780 , PK511 , PK522 , FA007 , LZ Series , L380 , DL380 , AA

TABLE OF SPECIFICATION SYMBOLS

	針數 Number of needles		旋梭 Hook		加固尺寸 Bar-tacking size
	線數 Thread numbers		切邊距離 Gauge width		孔位尺寸 Button sewing size
	針距 Needle gauge		壓腳手動提升 Presser foot hand lift		鈕釦長度 Button size
	包邊寬度 Overedge width		壓腳膝動提升 Presser foot knee lift		自動切線功能 Thread trimmer
	車縫距離 stitch length mm		針棒行程(mm) Needle bar stroke		壓具尺寸 Presser foot work clamp check size
	差動比 Differential feed ratio		功能碼 Function		釦眼尺寸 Button hole size
	使用針型號 Type of needle		自動切線 Auto thread trimmer		切刀尺寸 Knife size
	車縫速 Sewing speed		快速倒縫 Reverse feed		針距 Max. feeding amount
	壓具揚程 Presser foot lift mm		撥線桿 Wiper		最高擺針 Max zigzag width
	車縫圖形 Stitch pattern		自動抬壓腳 Auto lifter		跳距 Skip stitch
	車縫布料 Sewing material		拉布輪數 Puller numbers		針距 Needle gauge
	針板 Needle plate		上送具行程 Top Feeding Function mm		



General Seaming:

Closing hood, Sleeve, Leg & etc.

737K-504M2-04

747K-514M2-24 --> **K1**

757K-516M2-35



Zipper Attaching

DL7200 --> **L3**

DL7200B --> **L4**



Hot Air Sealing

DM-HT-SEALER-A2-PG(Brand: NPI)



Elastic Tape Attaching

737K-504M2-04/LFC-3

747K-514M2-24/LFC-3 --> **K5**

747K-514M2-24/SMK

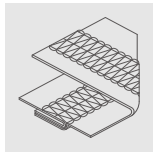

C007K-W322-356/CC --> C5

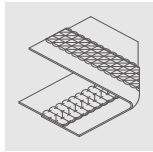

D007

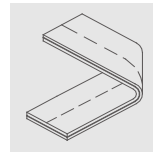

DL720 --> L1
DL7200 --> L3
DL7200B --> L4

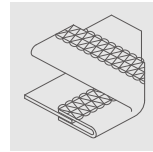

ASK-AMT100
700KS/ACS
700KS/KCL or RSK
C007K-W222-356/CQ --> C4
F007K-W222-356/FQ --> F2

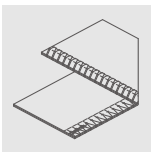

747K-514M5-23/BK --> K7
747K-514M5-23/BK-1
747L/LX-514M5-23/BKF
747K-514M5-23/BKF
747L/LX-514M3-24/BKT

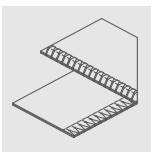

747L/LX-514M3-24
747K-514M2-24 --> K1

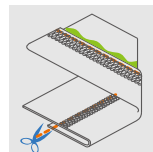

ASC-TBH100
C007K-W812(A)-356/CRL --> C13
C007L/LX-W815(A)-356/CRL/RL

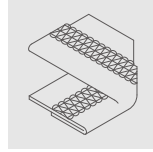

C007K-W122-356/CH --> C1
F007K(D)-W122-356/FHA --> F1
C007L/LX-W125-356/CH

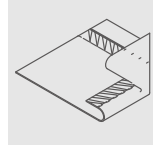

737L/LX-505F2-04
737K-505F1-04 --> K4

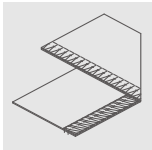

737KS(T)
747KS(T)
737FS-504M2-04
747FS-514M2-24

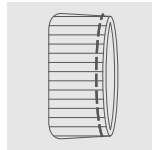

ASK-ASM100

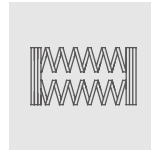

LBHS1790S
BH780 --> BH04

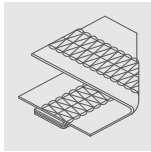

C007K-W322-356/CE --> C5
C007L/LX-W325-356/CE

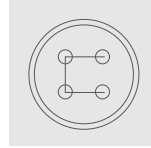

ASP-ABF100
LKS1903AN
PK511 --> PK01

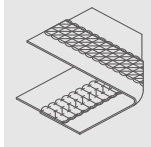

D007

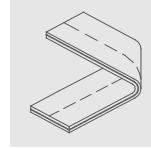

DL720 --> L1
DL7200 --> L3
DL7200B --> L4

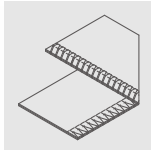

747L/LX-514M3-24/TG
747K-514M2-24/TG --> K3

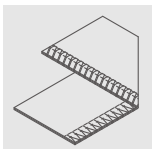

747L/LX-514M3-24
747K-514M2-24 --> K1
747K-514M5-23/BK --> K7
747K-514M5-23/BK-1
747L/LX-514M5-23/BKF
747K-514M5-23/BKF
747L/LX-514M3-24/BKT

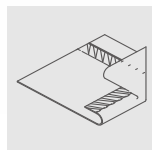

737L/LX-505F2-04
737K-505F1-04 --> K4

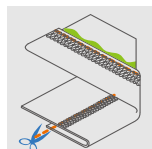

C007K(D)-W812(A)-356/CRL --> C13
C007L/LX-W815(A)-356/CR

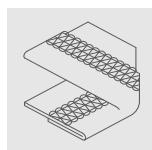

C007K(D)-W122-356/CH --> C1
C007L/LX-W125-356/CH

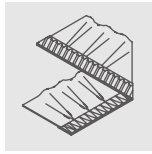

737KS(T)

747KS(T)

747K-514M2-24/LFC-3 --> K5

C007K-W122-356/CH --> C1

C007L/LX-W125-356/CH

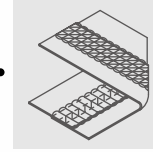
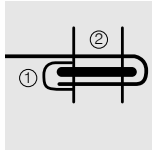

D007



SWIMMING WEAR

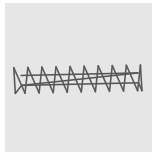

LKS1900AN
PK522 --> PK02

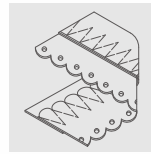

LZ457A --> LZ1

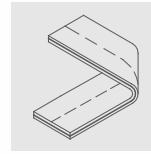

DL720 --> L1
DL7200 --> L3
DL7200B --> L4

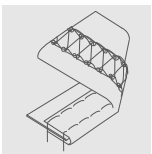
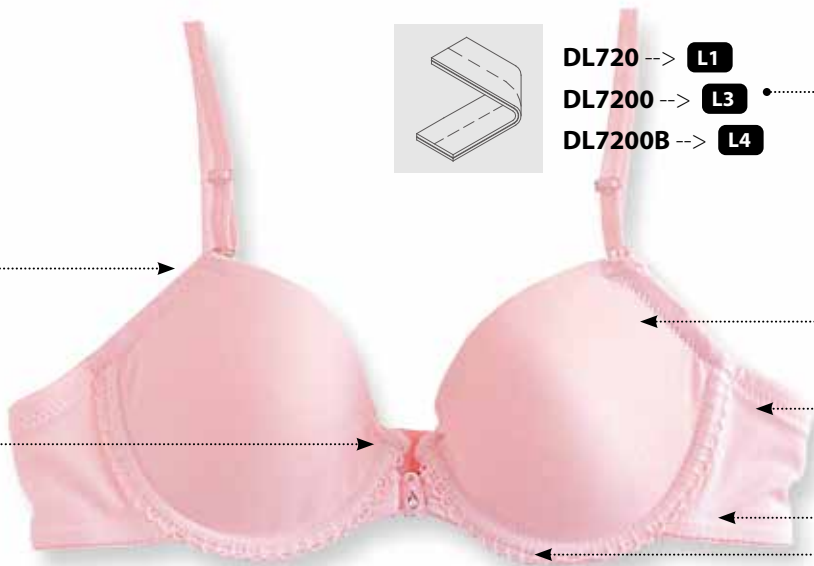

F007K-W522-232
 /FR/FQS--> **F7**

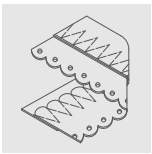

LZ457A --> LZ1

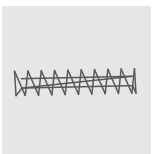

LKS1900AN
PK522 --> PK02

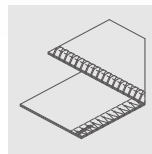

747K-514M5-23/BK --> K7
747K-514M5-23/BK-1
747L/LX-514M5-23/BKF
747K--514M5-23/BKF
747L/LX-514M3-24/BKT

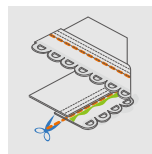

C007K-W522-356/CR/FFC --> C7
F007K-W522-356/FR/FFC --> F6

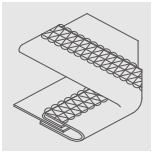

C007K-W152-356/CZ/RLQ --> C10

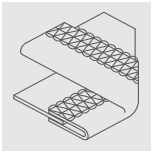

C007K-W222-356/CQ --> C4
F007K-W222-356/FQ --> F2

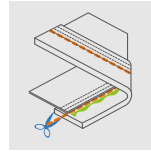

C007K-W532-356/CR/CX/UTP/RLP --> C8

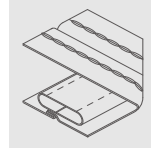

F007K-U712(A)-264/FSP --> F10

F007K-U712-496/FSS --> F10

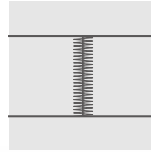

ASP-EBJ100
ASP-EBJ200

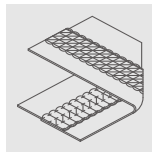

D007
F007K-W922-456/FW --> F13
C007K-W922-456/CW --> C12

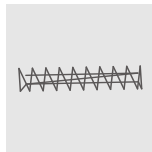

LKS1900AN
PK522 --> PK02

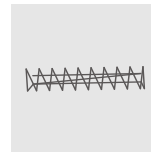

LKS1900AN
PK522 --> PK02

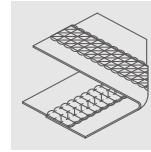

D007
F007K-W922-456/FW --> F13
C007K-W922-456/CW --> C12

MEN'S BRIEF

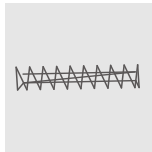

LKS1900AN

PK522 --> PK02

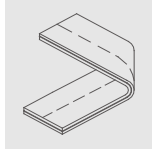

DL720 --> L1

DL7200 --> L3

DL7200B --> L4

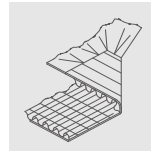

VC008A-04095P/VWL --> V4

VC008A-04095P/VWLB --> V5

VC008A-04095P/VWLC --> V6

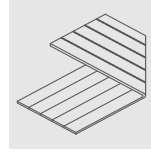

VC008B-04085P/VCE --> V3

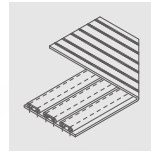

VC008B-06048P/VPL --> V8

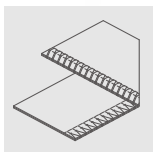

747L/LX-514M3-24

747K-514M2-24 --> K1

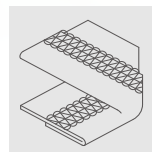

C007K-W122-356/CH --> C1

C007L/LX-W125-356/CH

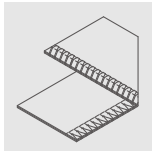

757L/LX-516M3-35
757K-516M2-35 --> **K1**

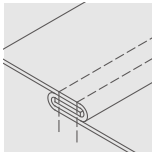

FA007 --> **FA1**

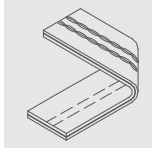

L382 --> **L11**

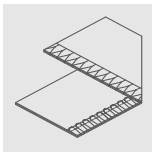

747L/LX-514M3-24
747K-514M2-24 --> **K1**

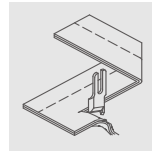

DL7300 --> **L5**

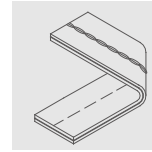

L381 --> **L11**

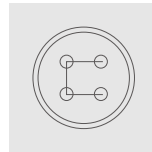

ASP-ABF100
LKS1903AN
BT290-A1 --> **BT02**
PK511 --> **PK01**

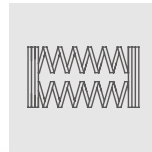

LBHS1790S
BH780 --> **BH04**

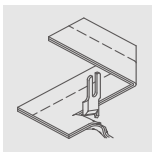

DL7300 --> **L5**

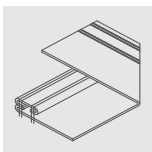

VC008B-0464-191P/VSF --> **V13**

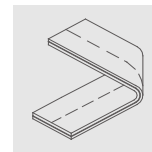

L720 --> **L1**
DL7200 --> **L3**
DL7200B --> **L4**

SHIRT

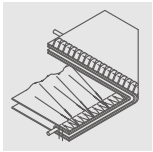

747L/LX-514M8-24/GA
747K-514H4-24/GA --> K6

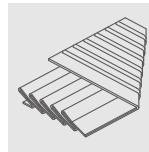

VC008A-12048P/VPT --> V12

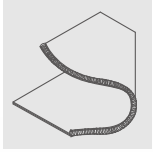

737L/LX-504F2-02/GAL
737K-504F2-02/GAL --> K2

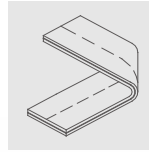

DL720 --> L1
DL7200 --> L3
DL7200B --> L4

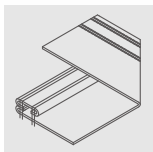

VC008B-0464-191P/VSF --> V13

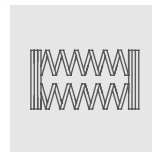

LBHS1790S
BH780 --> BH04

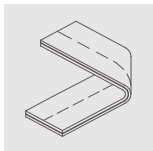

DL720 --> L1
DL7200 --> L3
DL7200B --> L4

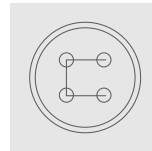

ASP-ABF100
LKS1903AN
BT290-A1 --> BT02
PK511 --> PK01

LADIES' OUTWEAR

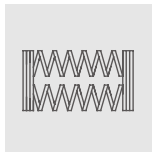

LBHS1790S

BH780 --> BH04

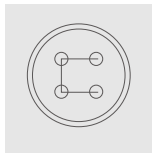

ASP-ABF100

LKS1903AN

BT290-A1 --> BT02

PK511 --> PK01

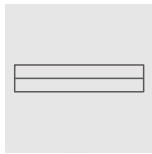

T828-42-127KL/C --> T2

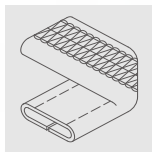

F007K(D)-U613-256/FBP --> F9

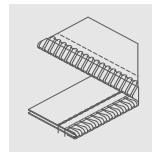

757L/LX-516M335/PS

757K-516M2-35/PS --> K9

757L/LX-401M8-50/TA

757K-401M2-50/TA

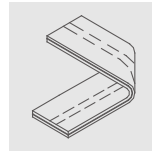

T828-42-32HL/C(拉鍊) --> T1

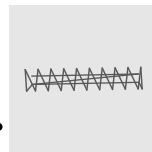

LKS1900AN

BT290-DS--> BT01

PK522 --> PK02

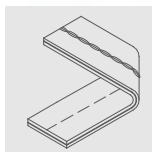

L381 --> L11

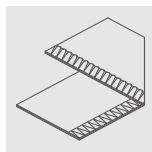

737L/LX-504M3-04

737K-504M2-04 --> K1

757L/LX-516M3-35

757K-516M2-35

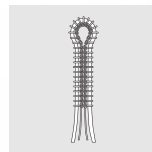

BH9820

MEN'S TROUSERS



AUTOMATIC SEWING

AS P - EBJ 100 / □□ / C

搭配機種
Model

P	電腦車 Programmable Bar-tacker
L	平車(單) Single-needle Lockstitch
K	拷克車 Overlock
V	VC008
C	C007
F	F007

功能
Function

EBJ	自動鬆緊帶搭接機 Automatic Elastic Ring Making Machine
ATS	自動三貼條車縫機 Three-Strip Attaching Multi Needle Sewing Machine
ACS	自動上圓領機 Automatic Ribbed Collar Attaching Machine
ASM 100	自動羅紋上袖口/褲腳機 Automatic Ribbed Cuff Attaching Machine
ASM 200	自動羅紋下擺機 Automatic Ribbed Hem Attaching To Wide Waistband Machine
TBH	自動T恤下擺折縫機 Automatic T-shirt Bottom Hemming Machine
SFS	自動縫線收尾加固縫機 Automatic suction Bartacking and cutting of Flatseam chain machine
PTA	自動上紙標機 Automatic Paper Tag Attaching Machine
ABF	電子釘扣機附自動送扣 Computer-controlled Lockstitch Button Sewing Machine with Auto Button Feeder

選配件
Optional Device

機型編號
Model Number

客制化
Customized

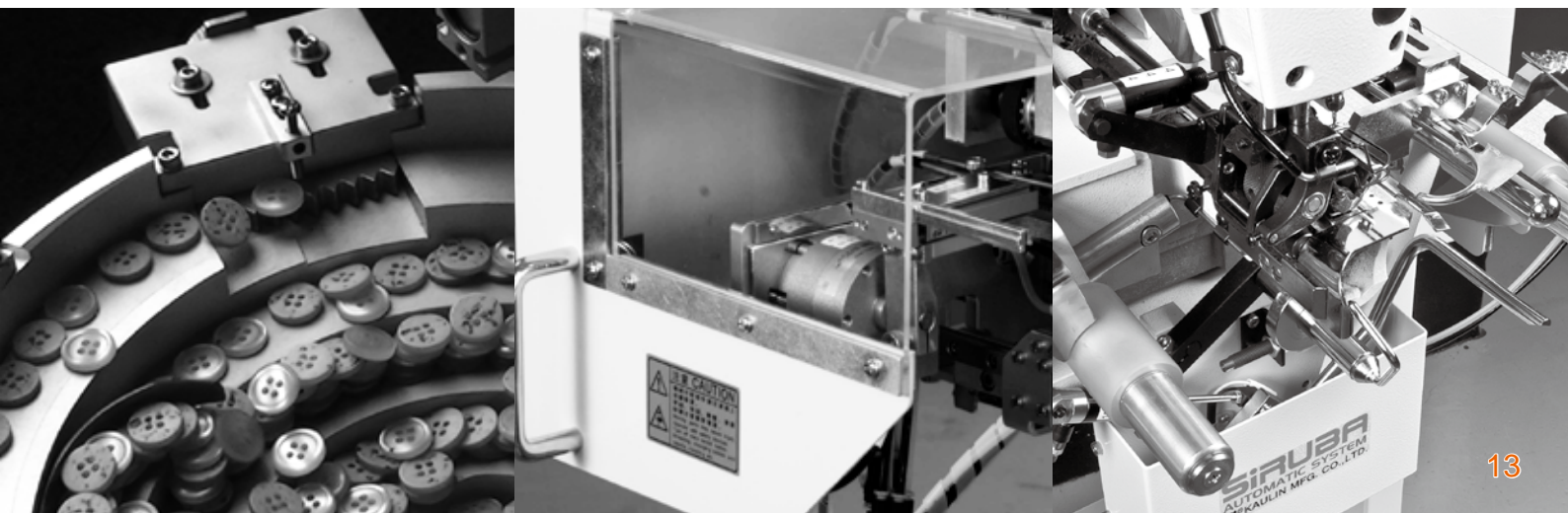

ASP-EBJ SERIES

自動鬆緊帶搭接機

Automatic Elastic Ring Making Machine



ASP-EBJ100A



ASP-EBJ150



ASP-EBJ200

特點

FEATURES

1 EBJ系列實現全自動鬆緊帶車縫。量測·裁剪·送料·車縫一系列連續動作·具有絕對的穩定度·精準可靠
EBJ Series realizes automatic sewing of elastic band. Measuring, cutting, feeding, and sewing are in sequence with absolute stability. It is accurate and reliable.

2 無人化生產·成品良率高·投資回收期短·最慢一年即可回收
Unmanned Production with high yield rate. Payback period is short as maximum 1-year ROI.

3 採用高階感知器·靈敏偵測入料狀況·具有即時報警·自動暫停功能
By high-end sensors, it detects the feeding sensitively with real-time alarm and auto pause function.

4 可選配整燙裝置·確保入料前的平整度·解決皺褶或扭曲的問題
Pre-ironing device is optional, which it ensures the flatness when the material is entering, to solve the problem of wrinkles or twists.

5 可選配視覺辨識系統·偵測Logo並依設定位置裁剪與車縫
Visual identification system is optional, which detects Logo and then positions cutting and sewing according to user's setting.



規格

SPECIFICATIONS

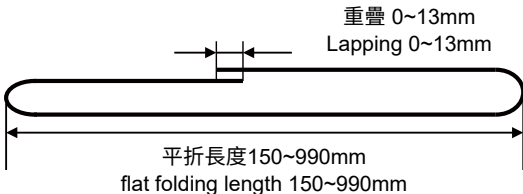
型號 Model	ASP- EBJ100A	ASP- EBJ100S	ASP-EBJ150	ASP-EBJ200
縫紉機機頭 Machine Head	JUKI LK-1920		JUKI LK-1920	JUKI AMS210ENSS
車縫速度 Sewing Speed	2500 SPM (最高 Max)			2800 SPM (最高 Max)
使用針型 Needle Type	DP×5 #14			DP×17 #14
線跡形式 Stitch type	單針鎖縫 #301 Single Needle Lockstitch #301			
鬆緊帶寬度 Rubber Width	20~50 mm	6~20 mm	20~50 mm	20~90 mm
車縫花型儲存 Pattern Memory	EEPROM			IP-420 (JUKI AMS)
最大儲存車縫花型數量 Max. Numbers of Pattern	99 種車縫花型 99 Patterns			999 種車縫花型 999 Patterns
切帶方式與材料 Tape Cutting Method	刀切 Knife Cutting			◎刀切 Knife Cutting △超聲波 Ultrasonic Cutting
生產效率 Production Capacity	視縫製針數而定 舉例: 190針縫製樣式的情形 下, 迴圈時間: 8秒/件; 3600 件/ 8小時 Depends on the stitch pattern, Ex: 190 stitches pattern, Cycle Time: 8 Sec./ pcs (Max.); 3600 pcs/ 8Hr	視縫製針數而定 舉例: 71針縫製樣式的情形 下, 迴圈時間: 6秒/件; 4800 件/ 8小時 Depends on the stitch pattern, Ex: 71 stitches pattern Cycle Time: 6 Sec./ pcs(Max.); 4800 pcs/ 8Hr	視縫製針數而定 舉例: 190針縫製樣式的情形下 迴圈時間: 8秒/件; 3600件/ 8小時 Depends on the stitch pattern Ex: 190 stitches pattern as below Cycle Time: 8 Sec./ pcs(Max.); 3600 pcs/ 8Hr	
縫紉尺寸 Stitch Length	 <p>重疊 0~13mm Lapping 0~13mm</p> <p>平折長度 150~990mm flat folding length 150~990mm</p>			
氣體消耗量 Air Consumption	30 公升/分 30 L/Min.			
氣壓 Air Pressure	0.5 MPa			
電源電壓 Power Supply	Single Phase 1Φ AC200~240V 50/60Hz			
消費電力 Power consumption	750 W (Max)	750 W (Max)	800 W (Max)	800 W (Max)
機器尺寸 Dimensions	(W)1230X(D)1030X(H)1530mm (With table and thread stand 含桌板、線架)			(W)1550X(D)1150X(H)1530mm (With table and thread stand 含 桌板、線架)
選配裝置 Optional Device				
收料裝置 Stacker	△	△	△	△
熱整燙裝置 Pre-Ironing	—	—	△	△
LOGO 辨識裝置 LOGO Identification	—	—	◎	◎

◎ 標配 Standard

△ 選配 Option

ASV-ATS100A

自動三貼條車縫機

Three-Strip Attaching Multi Needle Sewing Machine



特點

FEATURES

- 1** 特殊設計壓腳·快速縫合防止皺褶·可依不同特性進行調整
Custom-designed presser foot for Adidas 3-stripe sewing. Puckering free and adjustable.
- 2** 雙電眼控制·可減少廢料·節省人工裁切收料時間
Dual-sensor control to reduce material waste and save cutting/collecting time.
- 3** 最短收料長度150mm
Minimum finished length:150mm
- 4** 三顆馬達·獨立控制送帶·張力控制精準
Stripe feeding controlled by individual motors for a better feeding performance.

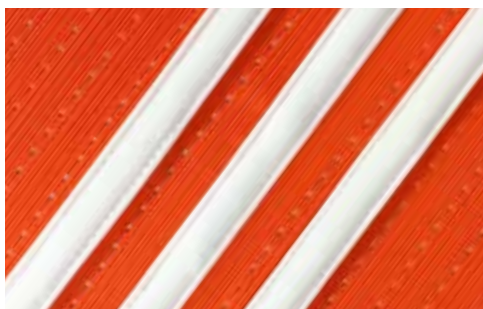

規格

SPECIFICATIONS

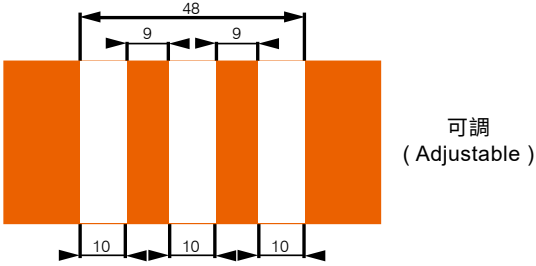
型號 Model	ASV-ATS100A
縫紉機機頭 Machine Head	SiRUBA VC008-06064P/VPL
車縫速度 Sewing Speed	2000 SPM (最高Max)
使用針型 Needle Type	UO×113GS #11
車縫平台寬度 Available Width of Stitching Platform	440 mm
縫紉針距 Stitch Length	6.4 mm
生產樣式 Sewing Pattern	 <p>可調 (Adjustable)</p>
氣體消耗量 Air Consumption	40公升/分 40 L/min
氣壓 Air Pressure	0.5 MPa
電源電壓 Power Supply	Single Phase 1Φ AC200~240V 50/60Hz
消費電力 Power Consumption	800 W (Max)
機器尺寸 Dimensions	(W)1200×(D)900×(H)1900 mm (With table and thread stand含桌板、線架)
生產效率 Production Capacity	車縫布長：600mm計算、縫距：2 mm、 車縫速度：1500 SPM、產速：3 件/min Cloth length：600mm、Stitch pitch: 2 mm、 Sewing speed: 1500 SPM、Output: 3 pcs/min

※收料限制：布料長度 150 mm 以上

※Material limit : essential requirement cloth length \geq 150 mm

ASK-ACS100

自動上圓領機

Automatic Ribbed Collar
Attaching Machine



特點

FEATURES

1

自動偵測縫骨位置·減少工人對位時間

Auto detect the collar seam, by sensor. shorten the rib marking time.

2

可調式張力控制機構·減少布料起皺現象

Tubular tension control system avoids puckering.

3

導布結構·車縫衣領與布身結合時·防止偏斜

Guiding platform ensures a quality joint of rib and fabrics.

4

電眼控制導布機自動開合

Automatically control the fabric feeding.



規格

SPECIFICATIONS

型號 Model	ASK-ACS100
縫紉機機頭 Machine Head	747KST-514M-3-24VT
車縫速度 Sewing Speed	4500 SPM (最高Max)
使用布料 Type of Fabric	彈性布料 Elastic fabric
使用針型 Needle Type	DC x 27 #11
縫紉針距 Stitch Length	0.5~6 mm
領圍車縫範圍 Applicable Collar Circumference	
領高車縫範圍 Applicable Collar Height	
布厚車縫範圍 Applicable Cloth Thickness	對折後 1.2 mm ±0.2 mm After fold 1.2 mm ±0.2 mm
氣體消耗量 Air Consumption	35公升/分 35 L/min
氣壓 Air Pressure	0.5 MPa
電源電壓 Power Supply	Single Phase 1Φ AC200~240V 50/60Hz
消費電力 Power Consumption	660 W (Max)
機器尺寸 Dimensions	寬 1200 × 深 670 × 高 1200 mm 安裝線架後 1600 mm 1200(W)X670(D)X1200(H) mm 1600 mm with thread stand
生產效率 Production Capacity	車縫速度：4000 SPM、車縫時間：1小時180-240件 Sewing speed: 4000 SPM、Cycle time: 1 Hr / 180-240 pcs

ASK-ASM100

自動羅紋上袖口/褲腳機 Automatic Ribbed Cuff Attaching Machine



特點

FEATURES

1 自動過骨感知偵測 · 設定結尾需求針數
Auto Seam Detector, easy to set the stitching.

2 快速調整機構 · 方便設定與維護
Quick release mechanism, easy for setting and service.

3 張力調整 · 自動拉伸 · 減少布料起皺
Tension controller for smooth feeding and puckering free.



規格

SPECIFICATIONS

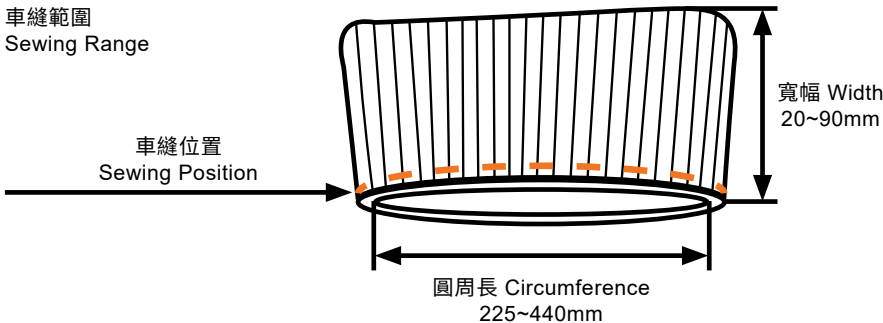
型號 Model	ASK-ASM100
縫紉機機頭 Machine Head	SiRUBA 747KST-514M-4-2
車縫速度 Sewing Speed	5500 SPM (最高Max)
使用針型 Needle Type	DC×27 #11
壓腳高度 Presser foot Height	7.5 mm
包邊寬度 Overedge Width	4 mm
縫紉針距 Stitch Length	2 mm
羅紋布尺寸 (mm) Rib Size (mm)	
布厚範圍 Fabric Thickness	6.5mm (Max)
氣體消耗量 Air Consumption	35公升/分 35 L/min
氣壓 Air Pressure	0.5 MPa
電源電壓 Power Supply	Single Phase 1Φ AC200~240V 50/60Hz
消費電力 Power Consumption	500 W (Max)
機器尺寸 Dimensions	(W)825×(D)640×(H)1622mm (With table and thread stand 含桌板、線架)
生產效率 Production Capacity	車縫速度：2 sec/pc (3000 spm，羅紋布尺寸 圓周長：270mm，高度：60mm) Sewing Speed: 2 sec/pc (3000 spm, Rib Size: Circumference: 270mm, Height: 60mm)

ASK-ASM200

自動羅紋下擺機

Automatic Ribbed Hem Attaching To Wide Waistband Machine



特點

FEATURES

1

撐布：可以依照商品需求做尺寸設定
Fabric tension: Can be adjust according to product requirements.

2

穩布：搭配Sensor穩布輪可將布邊穩定在 $\pm 2\text{mm}$ 內，使其送布量與切布量穩定
Fabric stability: Using sensor stabilizing wheel can stabilize the cloth edge within $\pm 2\text{mm}$, makes the feeding and cutting stable.

3

骨位偵測：螺紋布骨位自動感測定位功能
Seam detection: Automatic sensing positioning function for rib fabric seam.

4

疊縫設計：布料骨位感知偵測，簡單設定結尾疊縫需求針數
Overlapping stitching: End overlapping stitching counts can be simply set up by fabric seam detection sensor.

1



3

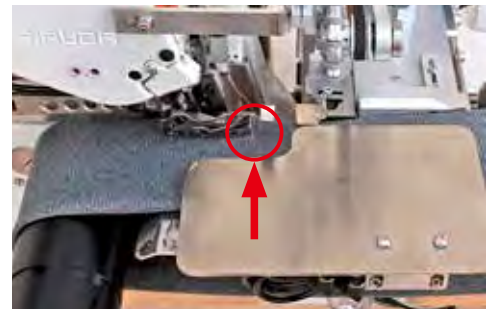

2



4



規格

SPECIFICATIONS

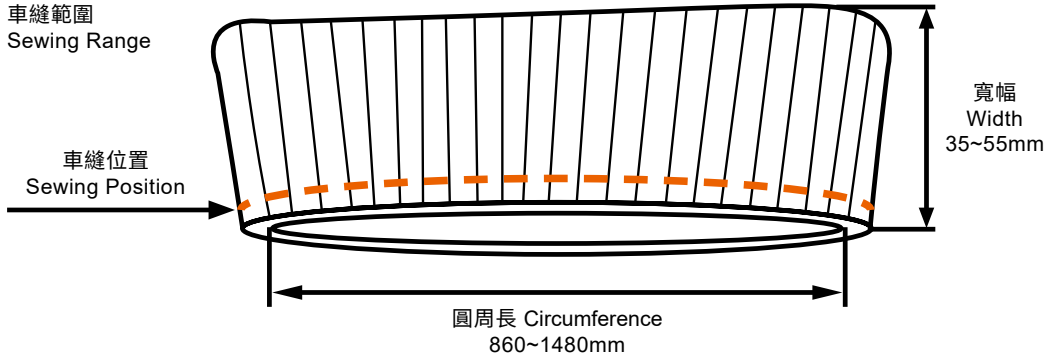
型號 Model	ASK-ASM200	
縫紉機機頭 Machine Head	SiRUBA 747KST-514M-4-24	
車縫速度 Sewing Speed	4500 SPM (最高Max)	
使用針型 Needle Type	DC×27 #11	
壓腳高度 Presser foot Height	7 mm	
包邊寬度 Overedge Width	6 mm	
縫紉針距 Stitch Length	0.5~6 mm	
羅紋布尺寸 (mm) Rib Size (mm)	 <p>車縫範圍 Sewing Range</p> <p>車縫位置 Sewing Position</p> <p>寬幅 Width 35~55mm</p> <p>圓周長 Circumference 860~1480mm</p>	
布厚範圍 Fabric Thickness	6.5 mm (Max)	
氣體消耗量 Air Consumption	400公升/分 400 L/min	
氣壓 Air Pressure	0.5 MPa	
電源電壓 Power Supply	Single Phase 1Φ AC200~240V 50/60Hz	
消費電力 Power Consumption	1K W (Max)	
機器尺寸 Dimensions	(W)1300×(D)790×(H)1640 mm (With table and thread stand 含桌板、線架)	
生產效率 Production Capacity	車縫速度：22 sec/pc (4500 spm，羅紋布尺寸 圓周長：980mm，高度：55mm) Sewing Speed: 22 sec/pc (4500 spm, Rib Size: Circumference: 980mm, Height: 55mm)	

ASC-TBH100

自動T恤下擺折縫機 Automatic T-shirt Bottom Hemming Machine



特點

FEATURES

- 1** 可縫製各式各樣的布料·適用性強·通過性高
Wide range of sewing material applicability.
- 2** 功能模組化設計：自動擴張系統、自動折邊裝置、自動糾偏系統、電動修布刀裝置、張力自動平衡系統及送料收料系統
Functional module design: extending roller system, edge folding device, direction keeping system, electric fabric edge trimmer, tension balance system, and collection system.
- 3** 雙蝸杆渦輪自動糾偏定位裝置·兩蝸杆驅動十渦輪結構·更穩定更完美地解決各種柔性面料
Due to dual-worm drive mechanism, the handling of soft material is perfect, which always keeps the sewing on the right direction.
- 4** 機器操作簡易·工作過程全自動化·放好布片·按開始鍵·機器就自動完成·生手經兩小時培訓練習·就能熟練操作
User-friendly! Fully sewing automation by loading the material, pressing one key and then sewing finished. From a beginner to be a quick operator by 2-hour training.
- 5** 兩側包縫倒骨同向裝置 (特別訂購)
Two sides' overlock seam folding device (Special order)
- 6** 散口預先包縫免修邊 (特別訂購)
Fabric edge serging prior to hemming (Special order)

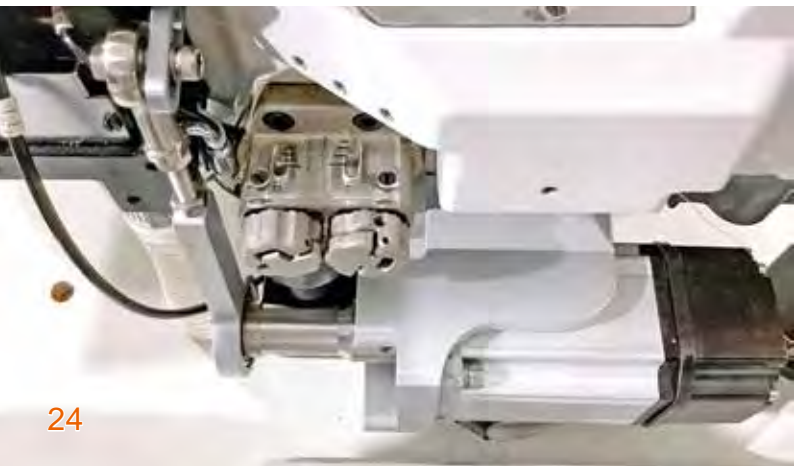

規格

SPECIFICATIONS

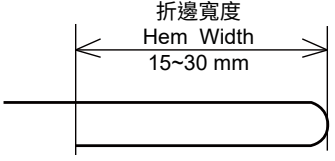
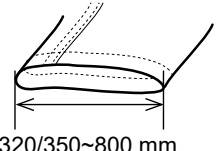
型號 Model	ASC-TBH100		
縫紉機機頭 Machine Head	上送筒型 / Top feed cylinder bed type C007KD-W812-□□□/CRL/FFT/UTP or S007KD-W812-□□□/SRL/FFT/UTT	針碼長度 Stitch Length	1.5-5 mm
車縫速度 Sewing Speed	4000 SPM (最高Max)	生產效率 Production Capacity	120~150 pcs/hour
折邊寬度Hemming Width	 <p>折邊寬度 Hem Width 15~30 mm</p>	適用周長(攤平) Circumference of T-shirt bottom(Flattened)	350-800 mm (C007KD) 320-800 mm (S007KD)  <p>320/350~800 mm</p>
使用針型 Needle Type	UY×128	縫紉針距 Stitch Length	4.0 / 4.8 / 5.6 / 6.4 mm 訂購時請選配 Optional by ordering
氣體消耗量 Air Consumption	8 L/min	消費電力 Power Consumption	850 W
氣壓 Air Pressure	0.6 MPa	機器尺寸 Dimensions	1550 x 1250 x 1500 mm
電源電壓 Power Supply	AC 220V , 50/60Hz	淨重 / 毛重 Net / Gross weight	250 KG / 320 KG

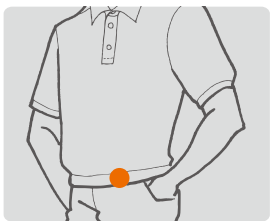

配置建議

Recommend Layout

一人操作兩台
One operator with two machines

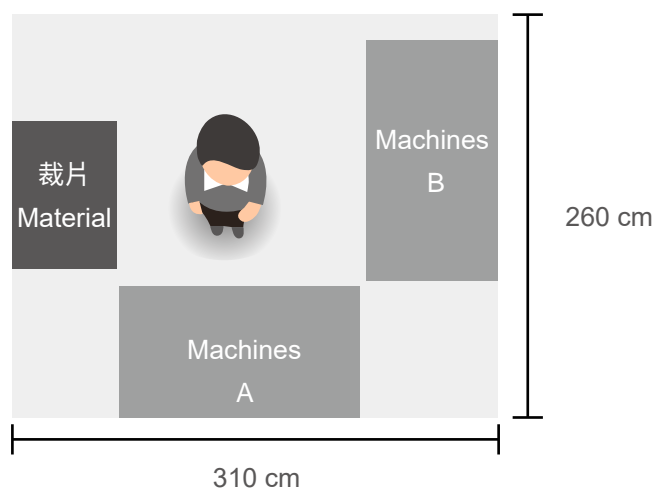

ASP-SFS SERIES

自動縫線收尾加固縫機

Automatic suction
Bartacking and cutting of
Flatseam chain machine



特點

FEATURES

1 對位凹槽方便操作員對位
Notch for alignment.

2 感測自動吸線·踏板啟動·壓腳、切線、自動套結車縫
Once the sensor detects the garment, the air suction will activate automatically and press the pedal to trim the flatseam chain and Bartacking Sensor.

3 小銅嘴(250mm)·作業員放布順手·容易操作
Small cylinder bed. Feed the garment with ease.

4 壓腳固定布面·滑動板送布設計·不傷布料·套結品質一致
Press the garment with presser foot and feed the garment with sliding plate to ensure the stable output.



型號 Model	ASP-SFS100A ASO-SFS100A	ASP-SFS100B ASO-SFS100B
縫紉機機頭 Machine Head	SiRUBA LKS-1900AN-FS	
車縫速度 Sewing Speed	2000 SPM (最高Max)	
使用針型 Needle Type	DP×5 #11	
車縫範圍 Sewing Range		
送布位置 Feeding Position	斜拉，壓腳位於中心右方 Pull oblique and presser foot is to the right of center	直拉，壓腳位於中心 Pull straight and presser foot is in the center
氣體消耗量 Air Consumption	175 L/min	
氣壓 Air Pressure	0.5 MPa	
電源電壓 Power Supply	Single Phase 1Φ AC200~240V 50/60 Hz	
消費電力 Power Consumption	100 W (Max)	
機器尺寸 Dimensions	(W)1200×(D)750×(H)1530 mm (With table and thread stand 含桌板、線架)	
生產效率 Production Capacity	車縫速度: 2000 SPM、車縫時間: 2.5秒/件、產速: 10秒/件 Sewing speed:2000 SPM、Sewing time:2.5 sec/pcs、Output:10 sec/pcs	

ASP-PTA SERIES

自動上紙標機 Automatic Paper Tag Attaching Machine



ASP-PTA101



ASP-PTA300

特點

FEATURES

- 1 彈性卡槽 · 方便調整 · 最高容量250張(厚度0.5mm)
Paper card loader is flexible for easy adjustment.
The capacity is up to 250 pieces.
- 2 旋轉缸更平滑與穩定 (ASP-PTA101)
Smooth and stable rotary cylinder
- 3 利用快拆裝置 · 快速調整紙卡尺寸
Card spec easy to adjust by quick release device.
- 4 單件車縫的週期時間 · 約為3-5秒鐘
Cycle time 3-5 sec
- 5 儲氣筒(選配) · 解決氣源不穩的問題
Air Tank (Optionl), solution to the unstable air supply.

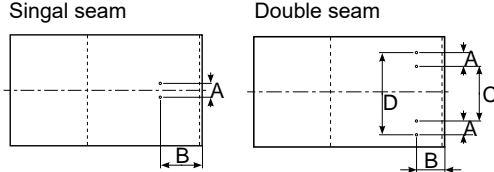
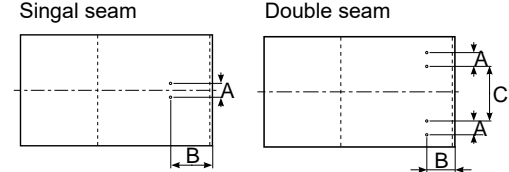
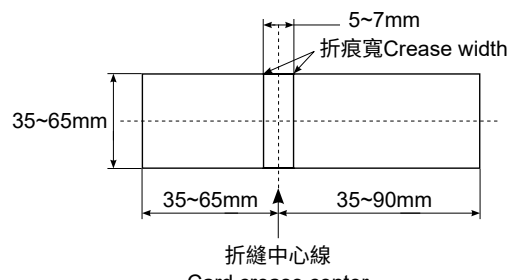
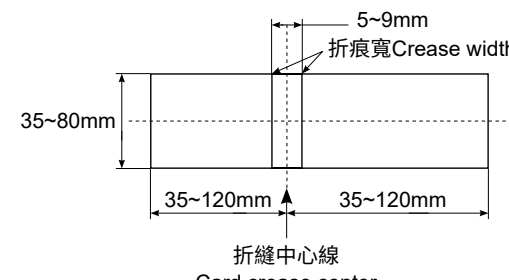

型號 Model	ASP-PTA101	ASP-PTA300
縫紉機機頭 Machine Head	SIRUBA LKS-1903AN	花樣 (電子循環車) JUKI AMS-201EN-1510
車縫速度 Sewing Speed	2000 SPM (最高Max)	2800 SPM (最高Max)
使用針型 Needle Type	DP×17 #11	DP×17 #11~14
紙卡單邊長 Card Length	Left 35~65 mm, Right 35~90 mm	Left 35~120 mm, Right 35~120 mm
紙卡寬度 Card Width	35~65 mm	35~80 mm
折痕寬度 Crease Width	5~7 mm	5~9 mm
紙卡厚度 Card Thickness	0.4~0.6 mm	0.4~0.6 mm
車縫範圍 Sewing range	<p>Singal seam Double seam</p>  <p>A 3~6mm B 15~30mm</p> <p>A 3~6mm×2 B 10~25mm C 20~30mm D ≤40mm (考慮縮放比例 Consider scale size)</p>	<p>Singal seam Double seam</p>  <p>A 3~6mm B 10~60mm</p> <p>A 3~6mm×2 B 10~60mm C 30~80mm</p>
適用紙卡規格 Card dimensions	 <p>5~7mm 折痕寬Crease width</p> <p>35~65mm</p> <p>35~65mm 35~90mm</p> <p>折縫中心線 Card crease center</p>	 <p>5~9mm 折痕寬Crease width</p> <p>35~80mm</p> <p>35~120mm 35~120mm</p> <p>折縫中心線 Card crease center</p>
氣體消耗量 Air Consumption	2 L/min	4 L/min
氣壓 Air Pressure	0.5 Mpa	
電源電壓 Power Supply	Single Phase 1Φ AC200~240V 50/60Hz	
消費電力 Power Consumption	660 W (Max)	
機器尺寸 Dimensions	(W)1050×(D)705×(H)1530 mm (With table and thread stand 含桌板、線架)	(W)1000×(D)750×(H)1530 mm (With table and thread stand 含桌板、線架)

ASP-ABF100

電子釘扣機附自動送扣

Computer-controlled Lockstitch Button Sewing Machine with Auto Button Feeder



ASP-ABF100



ASO-ABF100J



ASO-ABF100B

特點

FEATURES

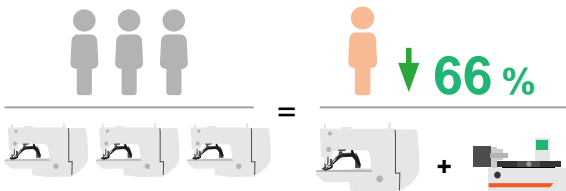

電子釘扣機附自動送扣比傳統縫扣機速度提升3倍
Button sewing machine with auto button feeder enhances 300% efficiency of button sewing.

循環時間: 2.2秒/顆; 13,090顆/ 8小時
Cycle Time: 2.2 Sec./Button; 13,090 Buttons/8 Hr



操作面板

簡單圖像式操作介面 · 所有車縫所需資料 · 皆能清楚顯示

PANEL

User friendly interface, all sewing parameters are clearly shown.



感知器訊號檢測

透過操作面板A02功能 · 檢測感知器訊號正常

SENSOR SIGNAL DETECT

Checking the sensors detecting by A02 function of operation panel.



翻扣機制

自動吹風翻扣功能 · 提高大尺寸鈕扣 (ø16mm以上) 的精確性

FLIP MECHANISM

Flip mechanism enhance the accuracy of ø16mm up button by auto air-blow.

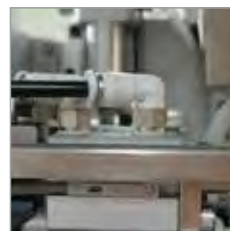

鈕扣夾爪自動感知器

可鈕扣夾爪偵測鈕扣位置 · 避免空縫

SMART SENSOR OF BUTTON CLAMP

Button clamp can detect the button position and avoid sewing without button.



送扣軌道調整

送扣軌道調整由步進馬達精準控制

BUTTON CHANNEL ADJUSTMENT

Channel adjustment is controlled by stepping motor accurately .



單鍵退扣

按鍵即可清空軌道內鈕扣

DISCHARGING

Press the key and then remove all the buttons in the channel.



電子式自動量測鈕扣

精準、極速，短時間內即可完成更換鈕扣設定

ELECTRONIC AUTOMATIC MEASUREMENT OF BUTTON SIZE

Accurate, Ultrafast, adjusting different button in a short time.



機頭上鈕扣夾爪

變換鈕扣尺寸時，鈕扣夾爪無須變更調整

BUTTON CLAMP OF MACHINE HEAD

Button clamp is suitable for variety button size, the clamp can be used in different button size and no further adjustment needed.



送扣載具模組化

可因應不同鈕扣規格，快速更換適合的送扣載具

BUTTON CARRIER MODULE

Modularized button carrier is for different button size and replacement.

規格

SPECIFICATIONS

型號 Model	ABF100J	ABF100B
適用車頭 Apply For	Juki LK-1903A/LK-1903B/ LK-1903AN	Brother 438FX
工作夾具提升量 Rising Amount of Clamp	最大:13mm Maximum:13mm	
餵扣時間 Feeding Time	0.35~0.5秒 0.35~0.5 Sec.	
使用鈕扣 Button	種類：圓形平扣 尺寸:Φ8~26mm ※Ø10mm以下為特規，須更換規格件 Type: Circle Flat Button Size: Φ8~26mm ※Ø10mm is special specification, need to replace standard parts.	
使用扣孔 Button Hole	標準：2或4孔 選配：3孔 Standard: 2&4 Holes Option: 3 Holes	
鈕扣厚度 Thickness of Button	1.5~3.5mm	
氣體消耗量 Air Consumption	20公升/分 20 L/min	
氣壓 Air Pressure	0.5 MPa	
電源電壓 Power Supply	單相AC 200~240V 50/60Hz single-phase AC 200~240V 50/60Hz	
機器尺寸 Dimensions	寬 440 × 深 560 × 高 280mm 440(W)x560(D)x280(H)mm	

Remark:

標配：專用桌板、腳架、鈕扣壓腳、底板、大小鋸齒板及12組標準送扣載具使用
選配：3孔扣孔、對位器、雷射燈對位器

*鈕扣尺寸定義：

超小鈕扣尺寸Φ8~10mm，小鈕扣尺寸Φ10~20mm，大鈕扣尺寸Φ20~26mm
鈕扣夾爪適用範圍Φ8~26mm，但縫製超小或大鈕扣時，需視鈕扣厚度與凸面的情況

**大小鋸齒板選用建議

使用鈕扣	尺寸:Φ8~16mm	尺寸:Φ16~25mm
	小鈕扣鋸齒板	大鈕扣鋸齒板

Remark:

Standard: Professional table, All Set of Button Presser Foot, Small/Big Button
Serrated Plate and Bottom Plate, 12 Sets of Standard Button Carrier.
Option: 3-Holed of Button Carrier, Button Spacer, Button Spacer with Laser Light.

*The definition of Button Size:

Extra small button size is Φ8~10mm, small button size is Φ10~20mm, and large button size is Φ20~26 mm. Basically, Button clamp of machine head is applied for Φ8~26mm, but that sewing extra/ large button size are depend on its thickness and convexity.

**Suggestion of selecting the serrated plate

Button	Size: Φ8~16mm	Size: Φ16~25mm
	The small serrated plate	The Big serrated plate

送釘載具模組規格

Button Carrier Specification

零件編碼 Codea of Parts	X +0.05 -0.05	D +0.05 -0.05	鈕扣孔數 Button Holes
ABF118	2.2	1.0	4
ABF119	2.2	1.0	2
ABF120	2.4	1.2	4
ABF121	2.4	1.2	2
ABF269	2.6	1.2	4
ABF270	2.6	1.2	2
ABF122	2.8	1.2	4
ABF123	2.8	1.2	2
ABF124	3.2	1.2	4
ABF125	3.2	1.2	2
ABF126	3.6	1.2	4
ABF127	3.6	1.2	2

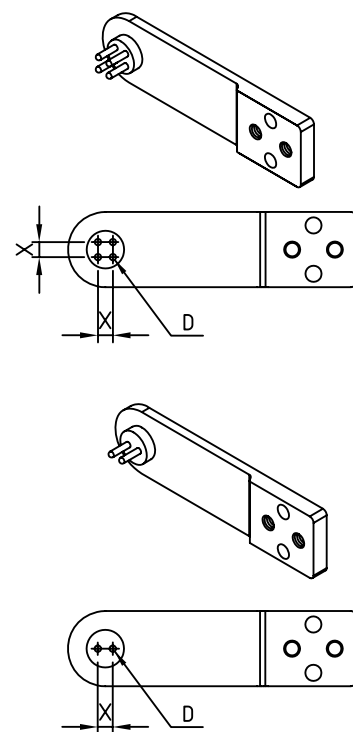

鈕扣型狀

Button Shape

適用鈕扣的形狀 Available Shape of Button	不適用鈕扣的形狀 Unavailable Shape of Button
<p>兩面須有明顯區別(落差)，凹或凸須在1.2mm差距以上，以順利判定正反面</p> <p>Two sides must be obviously different (Dissimilarity) For determining the positive or negative side, the convex or concave must above 1.2mm gap.</p>	<p>兩面皆相同之鈕扣，機器無法判別</p> <p>Machine can't work if one side of the button is identical to the other.</p>



OVERLOCK STITCH

700L 700LX 700KST 700KS 700KT

747 L - 514 M - 2 - 2 4 / VT

線數
Thread numbers

737	: 3T
747	: 4T
757	: 5T
767	: 6T

針距
Needle gauge

包邊寬度
Overedge width

配件
Device

機種別
Model

L	基本型 Basic Type
LX	微油型 Semi-Dry Type
KST	筒型上送包縫 Cylinder-bed Top-feed High Speed Overlock
KS	筒形包縫 Cylinder-bed High Speed Overlock
KT	上送包縫/安全縫 Top-feed High Speed Overlock/Safety Stitch

縫合方式
Sewing types

503	
504	
505	
512	
514	
516	
644 (514+401)	

車縫布料/上勾針縫容量
Sewing Fabric/Upper Looper
capacity

F	輕薄布料 Fine weight fabric
L	薄布料 Light weight fabric
M	中厚布料 Medium weight fabric
H	厚布料 Heavy weight fabric
X	特厚布料 Extra heavy weight fabric

送具型式
Feed dog type

1	1排 (標準) 1 row (standard)
2	2排 (標準) 2 row (standard)
3	3排 (標準) 3 row (standard)
4	4排 (標準) 4 row (standard)
5	5排 (標準) 5 row (standard)
6	1排 (特殊) 1 row (special)
7	2排 (特殊) 2 row (special)
8	3排 (特殊) 3 row (special)
9	4排 (特殊) 4 row (special)
0	5排 (特殊) 5 row (special)

OVERLOCK DD SERVO MOTOR

747L-514M-3-24 / ECA / DKL□□

配件
Device

- DKL□□ 700L/LX型直驅電控組
Direct-Drive Servo Motor for 700L/700LX
請參閱P.38-39 Detail on Page.38-39
- DKK□□ 700K/700KST/700KS/700KT型直驅電控組
Direct-Drive Servo Motor for 700K/700KST/
700KS/700KT
請參閱P.49 Detail on Page.49

卓越性能 來自不斷的淬煉

Excellent performance comes from
constant refinement



700L SERIES

700L

超高速包縫 / 安全縫縫紉機

Ultra High Speed Overlock/Safety Stitch Machine

700LX

微油型超高速包縫 / 安全縫縫紉機

Semi-Dry Ultra High Speed Overlock/
Safety Stitch Machine



700LX



700L series

在 SiRUBA 包縫機技術的既有基礎上，大幅度提升性能

Based on SiRUBA overlock technology, we greatly enhance the performance.

在控線與送布的根本性能的追求，實現了完美的縫紉品質

過線系統全面優化，在每一個細節都考慮了線的張力狀態，實現了極佳的控線能力。送具、壓具與切布刀的綜合調校，使得送布性能達到優化。在面料的厚薄適用性，700L在規格上有更全面的對應，實現了令人滿意的車縫品質

In pursuit of the core performance of thread controlling and fabric feeding, it realizes perfect sewing quality.

Threading system is fully optimized. As we fine-tuned every detail about the thread tension, it realizes a very good thread controlling. The feed dog, presser foot, and fabric trimmer are well coherent to make the fabric feeding optimized. Regarding the applicability range of fabric weight, 700L has a more comprehensive correspondence by specification, and realizes the satisfactory seam quality.

在機械精度的追求，達到高速運轉下的穩定性

提升零件的製造工藝，在精度、表面處理、內孔精加工和零件的輕量化設計，每一個細節都有嚴謹的配合，實現了高速、穩定、低噪音與低振動的機械性能

In pursuit of mechanical precision, it realizes the stability under high speed operation.

Improving the spare parts manufacturing process, the spare parts manufacturing process is improved. As the precision, surface treatment, micro-finish honing and parts light weight design are strictly coordinated in details, it realizes the high speed, stable, low noise and vibration mechanical performance.

車縫應用的範圍更寬

針對車縫面料的厚度，在規格上(包括規格組、上勾針行程、機構時位...等)有更全面的對應，在超薄或超厚的車縫情形，都有令人滿意的車縫品質

The bigger range of sewing application

Regarding sewing material thickness, we have a full specification (including gauge set, upper looper stroke, mechanical timing...etc) to satisfy customer requirement. We provide the nice seam quality in sewing fine or extra heavy material.

700LX series

SiRUBA 的乾式潤滑技術提供更乾淨的縫製體驗

Upgrade sewing experience with SiRUBA's state-of-the-art oil-free technology.

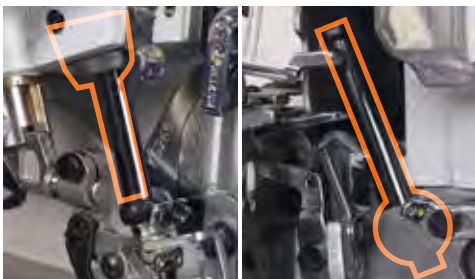

針棒與上勾針機構採特殊表面處理，縫製時無油污、無油漬飛散，在大幅提升縫製品質的同時，減少重工與縫製品髒汙的困擾

Needle bar and upper looper mechanism re-designed with new surface treatment, no oil stains and oil splash during sewing, greatly increase quality and reduce rework to achieve higher efficiency.

700L/700LX		布料厚度 Fabric Weight														
		L	M	H												
一般包縫 General Seaming	737L-503M-3-04				1	2	-	4	0.7-2	3.6	6	#11	7500			
	737L-504F-2-04				1	3	-	4	0.7-2	3.6	5	#11	7500			
	737L-504M-3-0□				1	3	-	4,5	0.7-2	3.6	6	#11	7500			
	747L-512M-3-25				2	4	2	5	0.7-2	3.6	5.5	#11	7500			
	747L-512M-3-34				2	4	3	4	0.7-2	3.6	5.5	#11	7500			
	747L-514M-3-2□				2	4	2	3,4,5	0.7-2	3.6	5.5	#11	7500			
	747L-514H-3-28				2	4	2	8	0.7-2	3.6	4	#11	6500			
	757L-516L-2-24				2	5	2	4	0.7-2	3.6	5.5	#14	7500			
	757L-516L-2-35				2	5	3	5	0.7-2	3.6	5.5	#14	7500			
	757L-516M-3-35				2	5	3	5	0.7-2	3.6	5.5	#14	7500			
	757L-516M-3-55				2	5	5	5	0.7-2	3.6	5.5	#14	7500			
	767L-644M-3-324				3	6	3+2	4	0.7-2	3.6	5	#11	7000			
767L-644M-3-524				3	6	5+2	4	0.7-2	3.6	5	#11	7000				
超薄布防起皺 Fine Fabric with Anti Puckering	747L-514F-3-23				2	4	2	3	0.7-2	3.6	5	#11	7500			
	747L-514F-3-24				2	4	2	4	0.7-2	3.6	5	#11	7500			
	757L-516F-2-34				2	5	3	4	0.7-2	3.6	5	#11	7500			
細包縫 Fine Edging	737L-504F-2-02/GAL				1	3	-	2	0.7-2	3.6	5	#9	7500			
	737L-504F-2-15				1	3	-	1.5	0.7-2	3.6	5	#9	7500			
	737L-504M-2-15				1	3	-	1.5	0.7-2	3.6	6	#9	7500			
肩帶包縫 Tape Inserting	747L-514M-3-24/TG				2	4	2	4	0.7-2	3.6	5.5	#11	7500			
	747L-514M-3-25/TG				2	4	2	5	0.7-2	3.6	5.5	#11	7500			
拷下擺 Blind Hemming	737L-505F-2-04				1	3	-	4	0.7-2	3.6	5	#9	7500			
鬆緊帶車縫 Elastic Attaching	737L-504M-3-04/LFC-3				1	3	-	4	0.7-2	3.6	6	#11	6500			
	747L-514M-3-2□/LFC-3				2	4	2	4,5	0.7-2	3.6	5.5	#11	6500			
	747L-514M-3-2□/SMK				2	4	2	4,5	0.7-2	3.6	5.5	#11	7500			
	737L-504M-3-04/TR				1	3	-	4	0.7-2	3.6	6	#11	7500			
摺景車縫 Gathering	747L-514M-8-24/GA				2	4	2	4	0.7-2	3.6	5.5	#11	7000			
	757L-516M-8-35/GA				2	5	3	5	0.7-2	3.6	5.5	#14	7000			
	757L-516M-8-55/GA				2	5	5	5	0.7-2	3.6	5.5	#14	7000			
手動線頭包縫 Manual Back Latching Seaming	737L-504M-7-04/BK(BK-1)				1	3	-	4	0.7-2	3.6	6	#11	7500			
	747L-514M-7-2□/BK(BK-1)				2	4	2	3,4,5	0.7-2	3.6	5.5	#11	7500			
	747L-514H-7-2□/BK(BK-1)				2	4	2	4,5	0.7-2	3.6	7	#16	7500			
全自動手動線頭包縫 Fully Auto Back Latching Seaming	737L-504M-3-04/BKF				1	4	2	4	0.7-2	3.6	6	#11	7500			
	747L-514M-3-23/BKF				2	4	2	4	0.7-2	3.6	5.5	#11	7500			

700L/700LX	布料厚度 Fabric Weight			針	針	針	針	針	針	針	針	針	針
	L	M	H										
厚毛衣料包縫 Over Seaming On Bulky Knitwear	747L-514H-4-24			2	4	2	4	0.7-2	3.6	7	#16	6500	
	747L-514H-4-25			2	4	2	5	0.7-2	3.6	7	#16	6500	
牛仔安全縫 Jeans Safety Stitch	757L-516H-3-5□			2	5	5	5,6	0.7-2	3.6	7	#16	6000	
	757L-516X-3-5□※			2	5	5	5,6	0.7-2	3.6	7	#16	6000	
厚毛衣料肩帶包縫 Tape Inserting On Bulky Knitwear	747L-514H-4-24/TG			2	4	2	4	0.7-2	3.6	7	#16	6500	
	747L-514H-4-25/TG			2	4	2	5	0.7-2	3.6	7	#16	6500	
口袋邊包縫 Pocket Binding	757L-516M-3-35/PS			2	5	3	5	0.7-2	3.6	5	#14	7000	
	757L-516M-3-55/PS			2	5	5	5	0.7-2	3.6	5	#14	7000	
	757L-401M-8-□0/TA			2	4	3,5	-	0.7-2	3.6	5	#14	7000	
	767L-644M-3-324/PS			2	6	3+2	4	0.7-2	3.6	5	#14	7000	
	767L-644M-3-524/PS			2	6	5+2	4	0.7-2	3.6	5	#14	7000	
管狀布條車縫 Spaghetti Sewing	737L-WR/LFC-3			1	3	-	-	0.7-2	3.6	-	#11	6000	
拉鍊包縫 Zip Seaming	737L-504M-3-05/PZ			1	3	-	5	0.7-2	3.6	6	#14	7500	
毛巾布邊車縫 Towel Edging	757L-401M-6/TW			1	2	-	-	0.7-2	3.6	5	#14	7500	

※ 搭配厚料修布角刀
With heavy material angle knife.

700L/LX直驅系列 700L/LX DD Motor Series

承續 700QD 系列的豐富實戰經驗，SiRUBA 電控技術再提升
Based on the rich experience of 700QD Series, SiRUBA upgrades the control technology.



採用高速伺服馬達

- 以充沛的動力，實現7500 RPM的運轉速度
- 製造精度高，噪音小，發熱低

The high speed servo motor

- By the plenty power, it realizes the operation speed of 7500 RPM.
- High precision makes low noise level and low heat.

採用新型電眼，更靈敏，更精準，偵測無死角

- 體積極小，安裝於車布板下方，單一方向偵測布邊
- 不需調整電眼位置，適用於各種車縫作業情形
- 克服因棉絮阻擋而造成感測失靈的問題

The new sensor is more sensitive, more accurate, no blind spot.

- It is very small, installed under the sewing bed, detecting the fabric by single direction.
- No need to adjust the position, apply to a variety of sewing operations.
- Overcoming the problem of sensory failure due to dust blocking.

控制器模組化設計，以多種組合，全方位滿足各種需求

- 經濟型：節能省電，並可驅動EC切布條裝置
- 多功能型：標配電眼，偵測布料邊緣，以進行自動模式車縫，並可切換半自動或手動模式
- 多功能型分為氣動型與電動型，依客戶的廠房設備，選擇適合的規格

The controller modularized design, with a variety of combinations, comprehensively meets the various demands.

- Economic type: Energy saving, and also drives EC device, electrical tape cutter
- Multi-function type: the sensor checks fabric edge for automatic sewing mode. Also semi-auto or manual mode can be switched on demand.
- Multi-function type includes pneumatic and electrical type. Customers may choose the suitable specification according to the factory facility.

700L/700LX

產品組合：配件與直驅電控組

Product Package: Devices and Direct-Drive Control Sets

直驅電控組 Direct-drive Control Set	配件 Device	功能 Function	配件表 Accessory List												
			電眼 Sensor	安全 開關 Safety Switch	操作 面板 Control Panel	手動 開關 Manual Cut Switch	鬆線 Thread Release	切布條 Tape Cutter	吸風切線 Suction Trimmer		LED 照明 LED Light	立式 踏板 Standing Operation Padel	抬壓腳 Auto Foot Lifter	吸風組 Suction Set	針板 Needle Plate
									側切 Side Cutter	平切 Flat Cutter					
DKLH□-0 經濟型 Economic Type		一般車縫 General Sewing									●				
	VT	吸風切線 Suction Thread Trimmer								●		●		#4	#3 #4
	CT	吸風切線 Suction Thread Trimmer									●	●		#4	#3 #4
	AC	氣動切布條 Pneumatic Type Tape Cutter				●		●			●				
DKLH□-1 多功能 氣動型 Multi-function Pneumatic Type	ECA	氣動切布條 Air Type Tape Cutter	●	●	●	●		●			●	#2	●	●	
	VTE	吸風切線 Suction Thread Trimmer	●	●	●		#1		●		●	#2	●	●	
	VTA	吸風切線 Suction Thread Trimmer	●	●	●		#1		●		●	#2	●	●	
	CTE	吸風切線 Suction Thread Trimmer	●	●	●		#1			●	●	#2	●	●	
	UC	上下層防捲邊 Top and Bottom Anti-Curly Edge		●	●				●		●	#2	●	●	
	SD	圓領衫頸後貼條 T-Shirt Neck-back Tape Attaching		●	●				●		●	#2	●	●	
	BKT	簡易型自動包線頭 Simplified Auto Back Latch	●	●	●	●	●	●			●	#2	●	●	
DKLH□-2 多功能電動型 Multi-function Electric Type	ECB	電動切布條 Electric Type Tape Cutter	●	●	●	●		● Solenoid Type			●	#2	● Solenoid Type	●	

標準型
Standard

直驅電控組 Direct-drive Control Set	配件 Device	功能 Function	配件表 Accessory List													
			電眼 Sensor	安全 開關 Safety Switch	操作 面板 Control Panel	手動 開關 Manual Cut Switch	鬆線 Thread Release	切布條 Tape Cutter	吸風切線 Suction Trimmer		LED 照明 LED Light	立式 踏板 Standing Operation Padel	抬壓腳 Auto Foot Lifter	吸風組 Suction Set	針板 Needle Plate	
									側切 Side Cutter	平切 Flat Cutter						
DKLU□-0 經濟型 Economic Type		一般車縫 General Sewing										●				標準型 Standard
DKLU□-1 多功能型 Multi-function Type	ECA-U	氣動切布條 Air Type Tape Cutter	●	●	●	●			●			●	#2	●	●	加長型 Long type
	ECB-U	電動切布條 Electric Type Tape Cutter	●	●	●	●			●			●	#2	● Solenoid Type	●	
	VTE-U	吸風切線 Suction Thread Trimmer	●	●	●	●	●			●		●	#2	●	●	
	CTE	吸風切線 Suction Thread Trimmer	●	●	●	●				●	●	●	#2	●	●	

備註:

● 標準配備 / # 選配

#1: BK321-4

#2: EC467-A

#3: 1. TUA-31 需有空壓設備

2. TUD-2 無電刷馬達驅動

#4: TUA-32K 需有空壓設備

Remark:

● Standard accessory / # Optional accessory

#1: BK321-4

#2: EC467-A

#3: 1. TUA-31 Air compressor is required.

2. TUD-2 Driven by Brushless motor

#4: TUA-32K Air compressor is required.

TUA-3X

三合一吸風集塵組

3-IN-1 SUCTION DEVICE

代號 Code	功能組件 Functional Section			搭配 配件 Collocated Device	適用機型 Applicable Model
	三吸組 3-In-1 Suction Set	氣動抬壓腳 Pneumatic Presser Foot Lifter	機械閥 Mechanical Type Air Switch		
TUA-31	V	V	單聯 Single way	VT CT	700L /700LX
TUA-32K			雙聯 Double ways		



備註: 吸風組為 700L 電眼型之標準配備

Remark: The suction set is standard accessory of 700L sensor type models.

ECA
ECB

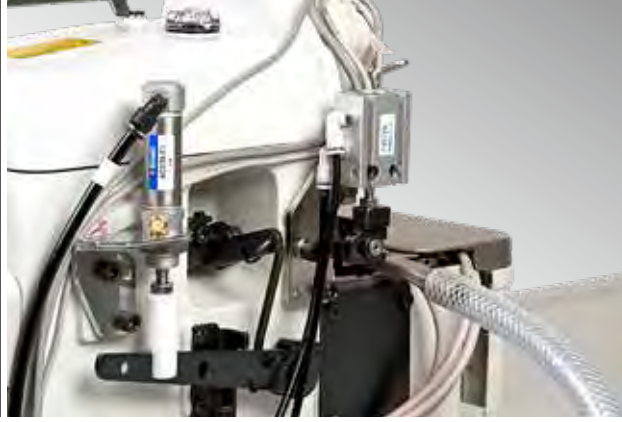

UC

CTE
VTA
VTE



BKT

ECB-U



ECA**氣動式切刀**
PNEUMATIC TYPE TAPE/THREAD CUTTER

採用新一代的電眼，性能再升級。ECA為氣動式，ECB為電動式，搭配吸風線槽，操作更順暢。

1. 手動、半自動及全自動操作模式，附轉換按鍵，且可透過操作面板調整。

2. 防誤切保護裝置：切刀旁安裝一電眼，如有被遮擋的狀況下，切刀不會動作，能有效地防止切刀誤切到布料。

3. 手動切線補償按鍵，如因操作問題沒有切斷線，可透由此按鍵進行手動切線。

4. 手動模式下，可後踩踏板切線。

5. 針對網紗、強反光絲光棉等特殊面料，採用專業的電控程式控制，均能輕鬆車縫及完成切線，不會造成切刀誤切。

Brand new sensor upgrades the performance. ECA is pneumatic type, and ECB is electric type, compatible with air suction slot, which makes the operation more smoothly.

1. Manual, semi-auto and fully-auto operation mode, attached the switch keys, and could be adjusted by the panel.

2. Mistake-proof protection device: One sensor equipped near the trimmer. If the sensor is blocked, the trimmer is deactivated effectively for avoiding from cutting the fabric.

3. Manual trimming compensation stitch key: If the thread is not cut due to the operation, it can be done by the key.

4. Under the manual mode, it could be fully backward pedaled to cut the thread.

5. For those special fabrics such as mesh fabric, mercerized cotton etc, the stitches are easily accomplished as well as the trimming by the professional computer controlled without mistake-trimming.

CTE**水平式 吸風切線(附電眼節能裝置)**
FLAT TYPE SUCTION CHAIN-CUTTER (WITH SENSOR-CONTROLLED ENERGY-SAVING DEVICE)

以電眼偵測布邊，控制吸風功能在切線時運作，減少空壓設備的能源消耗，並避免縫線浪費。

1. 垂直式吸風切線適合內褲廠等輕薄及不規則的針織面料車縫，提升效率。

2. 切刀之吸風口的設計使得切線更加快速。

3. 針對網紗、強反光絲光棉等特殊面料，採用專業的電控程式控制，均能輕鬆車縫及完成切線，不會造成切刀誤切。

4. 「切線後自動停車功能」以及「無面料即不車縫功能」可減少縫線的浪費。

5. VTA以氣缸推動切刀，減少刀刃磨耗，大幅延長使用壽命。

Electric eye (sensor) checks the fabric edge. It saves the energy consuming of air compressor system and also saves thread consuming.

1. Vertical suction trimming is suitable for sewing the light fabric like under-wear or irregular knitwear, to improve the efficiency.

2. The design of the suction inlet of the trimmer makes the trimming faster.

3. For those special fabrics such as mesh fabric, mercerized cotton etc, the stitches are easily accomplished as well as the trimming by the professional computer controlled without mistake-trimming.

4. Functions with auto stop sewing after trimming and with no fabric can save the stitches.

5. VTA trimmer is controlled by air cylinder, which reduces the blade stroke times and extends the durability.

BKT**簡易式自動包線頭**
SIMPLY AUTO BACK LATCH

為ECA延伸功能，車縫效率極高，針板有特殊風道設計，線頭在切線後，瞬間吸回，線頭長度約3cm。

It is an ECA extending function. The sewing efficiency is very high. Special needle plate suction channel is for thread-end down turning. It pulls back the chain while a wink. The back latch length is about 3cm.

SD**圓領衫頸後貼條**
T-Shirt Neck-back Tape Attaching

以氣動方式控制喇叭的水平位置(布條上料與切斷)，標準喇叭之規格：入布寬度36mm，出布寬度18mm。

Control the folder's horizontal positions (tape feeding and cutting). Standard folder's specification: Tape width 36mm, finish width 18mm.

ECB**電動式切刀**
SOLENOID TYPE TAPE/ THREAD CUTTER**ECB-A****ECB+ 氣動吸風組**
ECB+ PNEUMATIC SUCTION SET**UC****上下層防捲邊**
TOP AND BOTTOM ANTI-CURLY MATERIAL

針對易捲曲布料所開發的氣動裝置，在布料進入壓腳之前，將布料吹平，可適用上捲、下捲等各種捲曲的情形，大幅增加車縫效率。

The pneumatic device solves the problem of curly edge material. The fabric edge is flattened by air before entering the presser foot. Applicable to up-roll, down-roll, and all kinds of curly edge situations, which highly improves the sewing efficiency.

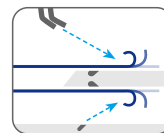

▲ 外捲模式
Up-roll

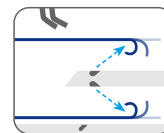

▲ 內捲模式
Down-roll

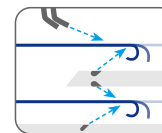

▲ 內外捲模式
Up-roll and Down-roll

700KS/KST SERIES FEATURES

700KS 高速筒型包縫機
High Speed Cylinder Bed Overlock Machine

700KST 高速筒型上送包縫機
High Speed Cylinder Bed Top Feed Overlock Machine



延續700K系列之特點，發展筒型機構延伸成為700KS系列。再增加新型獨立驅動的上送具機構，延伸成為700KST系列

- 筒嘴周長: 148mm
- 縫距調整: 按鈕式
- 差動比調整: 手杆式
- 潤滑系統: 全自動

Succeeding 700K Series' features, we develop cylinder bed mechanism to extend to 700KS Series. Moreover, with brand new independent-drive top feed mechanism, it extends to 700KST Series.

- Cylinder Bed Circumference: 148mm
- Stitch Length Adjustment: Push-button
- Differential Feed Ratio Adjustment: Lever type
- Lubrication: Fully-automatic

700KS

											選購配件 OPTIONAL DEVICE
下擺盲縫 Blindstitch Hemming	737KS-505F-2-04	1	3	-	4	0.7~2.0	3.8	5	#9	6500	VT LFD6K-□ RLK-□
	737KS-505F-2-04/ESK										
一般包縫 General Sewing	737KS-504M-3-0□	1	3	-	3,4,5	0.7~2.0	3.8	5	#11	6500	
	737KS-504H-3-0□	1	3	-	3,4,5	0.7~2.0	3.8	6	#11	6300	
	747KS-514M-3-2□	2	4	2	3,4,5	0.7~2.0	3.8	5	#11	6500	
	747KS-514H-3-2□	2	4	2	3,4,5	0.7~2.0	3.8	6	#11	6300	

700KST

											選購配件 OPTIONAL DEVICE
下擺盲縫 Blindstitch Hemming	737KST-505F-2-04	1	3	-	4	0.7~2.0	0.5~6	3.8	5	#9	6300
一般包縫 General Sewing	737KST-504M-3-0□	1	3	-	3,4,5	0.7~2.0	0.5~6	3.8	5	#11	6300
	737KST-504H-3-0□	1	3	-	3,4,5	0.7~2.0	0.5~8	3.8	6	#11	6000
	747KST-514M-3-2□	2	4	2	3,4,5	0.7~2.0	0.5~6	3.8	5	#11	6300
	747KST-514H-3-2□	2	4	2	3,4,5	0.7~2.0	0.5~8	3.8	6	#11	6000



ESK 電子盲縫拷下擺裝置
Electric hemming guide

ESS 電子盲縫拷下擺裝置(附自動升起功能)
Electric hemming guide (with auto-rising function)

盲縫拷下擺之車縫工序中，ESK可防止在過骨時發生脫線問題，配備齊全的直驅馬達，VT吸風切線，TUA集塵組，自動抬壓腳

In blindstitch hemming operation, ESK prevents stitch skipping or ply-shifting at the cross seam sections. The full set includes direct-drive servo motor, VT side suction trimmer, TUA suction set, auto foot lifter.

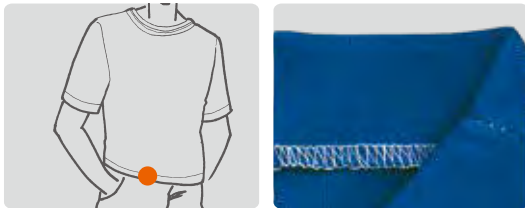

上圓領系列

CIRCULAR COLLAR ATTACHING SERIES

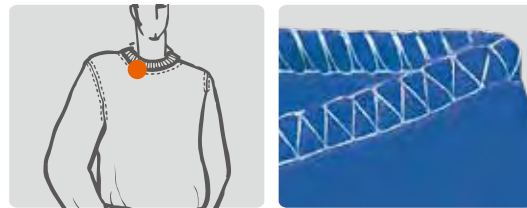

KCL



RSK



ACS

KCL 氣動導布與撐開輪組

RSK Pneumatic guide and tubular extending Roller set

氣動式導布帶組，左右兩側緊靠圓領布帶，配合滾輪撐開組，使得圓領布帶能夠穩定的前進，車工只需控制大身裁片，提升效率，降低車縫工序的難度

Pneumatic tape guide set holds the neckband's right and left side. With tubular extending roller set, the neckband tape can move forward stably so that operators can focus on fabric control, which improves the efficiency and reduces the difficulty of sewing operation.

氣動導布與撐開輪組(附自動定位功能)

ACS Pneumatic guide and tubular extending Roller set (with auto-positioning function)

在氣動導布與滾輪撐開的基礎上，加上自動順布條，接縫骨自動定位，減少90%的上料時間

Based on Pneumatic tape guide and tubular extending roller set, with advanced function as Automatic tape alignment, automatic Joint-seam positioning, which reduce 90% material loading time.



LFD6K 多功能自動鬆緊帶包縫(700KS 適用) Multi-function computerized automatic elastic attaching (700KS Applicable)

對於鬆緊帶之包縫，可利用電腦控制，進行自動切帶與自動送帶。可設定多段之鬆緊度與車縫長度，適用於泳衣、緊身衣、內褲等小口徑鬆緊帶上帶車縫，新增以下特點

送具下沉功能：壓腳抬起時，送具自動下沉，確保送帶零干擾

直驅伺服馬達：電控功能高度整合，動作配合更精確

觸控面板：圖形介面，設定更容易，添加測試模式，更快上手

For attaching elastic tape on small openings of swimsuit, leotards or brief, etc. By computer control, with auto cutting and auto tape feeding, elastic tape sewing can be done by multi-section tension and length., with the below features:

Feed dog dropping function : when presser foot lifts, the feed dog drops to ensure tape feeding without obstacle.

Direct drive servo motor : Electrics highly integration realizes the accurate series movements.

Touch panel : Graphical user interface is easy for setting. New added testing mode is easy for beginner.

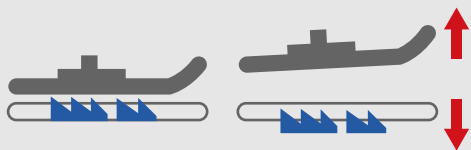

送帶 / 切帶功能

- 自動、手動、測試，三種操作模式。自動 / 手動換段，配備 LED 段數燈號
- 送帶精準，以 mm 為單位設定送帶長度
- 可調式前送帶，延遲送帶，倒帶功能，前送帶時可追加倒帶之功能
- 送帶速度補償，10 組預設值可供選擇
- 因應實際車縫狀況，車縫中可手動強制送帶 / 倒帶。車縫中遇失敗，可自動 / 手動調整至原工程第一段
- 吹氣送帶功能

TAPE FEEDING / CUTTING

- 3 operation modes: Auto, Manual, and Test. Auto/ Manual section changing with LED indicate lamp.
- Precise feeding and the length setting unit is mm.
- Adjustable feeding of forward, delay, reverse, and forward feeding with reverse function.
- Speed compensation with 10 default values for choice.
- For different sewing situations, active feeding may be applied by forward/ reverse when sewing. If sewing operation failed, auto/ manual return to the first section of sewing program.
- Air blow tape feeding function.

設定 / 記憶功能

- 連續縫記憶組數：10 組
- 工程段數：18 段
- LCD 面板顯示設定狀況、操作模式、錯誤代碼

SETTING / MEMORY

- Memory of sewing program set: 10 sets
- Program section: 18 sections.
- LCD panel shows setting status, operation mode, and error code.





其他附屬功能

- 鬆線功能
- 吸風切線之省風節能：起始 / 結束吸風時間可以調整（以針數計算）
- 回踩自動抬壓腳功能

Additional Function

- Thread releasing
- Suction trimmer's energy saving: Starting/ Ending air suction's time is adjustable. (by stitch counting)
- Auto presser foot lifting by paddle step-back.

LFD6K 規格 / SPECIFICATION



連續縫記憶組數 Program set memory	10組 10 sets
每組連續縫工程段數 Sections of every program	18段 18 sections
送帶距離/每針 Tape feeding length per stitch	0.2mm ~ 6.5mm
最高縫速(送距5mm) Max. Speed (stitch length 5mm)	4200 R.P.M
編碼器 (定位器) Encoder (synchronizer)	48段脈波 48-pulse
送帶馬達 Tape feeding motor	五相步進馬達 5-phase stepping motor
工作電壓 Voltage	AC 110~220 V

選配 / OPTIONAL



▼ 適用非直驅型
Applicable to non-direct-drive type



Code	Description	Remark
LFD6-K	短滾輪：適用16mm以下之鬆緊帶 Short roller: for tape width 16 mm below	標配 Standard
LFD6A-K	長滾輪：適用16mm~50mm之鬆緊帶 Long roller: for tape width range 16mm~50mm	標配 Standard
LFA	電動式上送帶裝置 Electric tape feeding device (Voltage 110~ 220V)	選配 Optional
LF290-A□	抖帶輪 □代表電壓, 1: 110V, 2: 220V Euntangling wheel □=Voltage LFR-1: 110V, LFR-2: 220V)	選配 Optional
VT*	垂直式自動吸風切線 Vertical Pneumatic chain cutter	標配 Standard
TU*	空氣控制閥/集塵裝置 Dust collector suction device	標配 Standard
TSA-400	伺服馬達, 含內置定位器 Servo motor with built-in synchronizer	選配 Optional

* 標準配備不列入機型名稱

*Standard devices are not mentioned in model name.



RLK1

筒型撐開輪組

Tubular Extending Roller set



RLK2

筒型撐開輪組

Tubular Extending Roller set



RLK3

筒型撐開輪組

Tubular Extending Roller set



RLK3P

筒型撐開輪組

Tubular Extending Roller set

建議組合

Recommend Package

- TUA-38S(ST)
- DKH201ADE-A
- 700KS-T1-P

700KT SERIES FEATURES



700KT 高速上送包縫機 High Speed Top Feed Overlock Machine

延續700K系列之特點，增加新型獨立驅動的上送具機構，延伸成為700KT系列。

- 縫距調整: 按鈕式
- 差動比調整: 手杆式
- 潤滑系統: 全自動

Succeeding 700K Series' features, we develop brand new independent-drive top feed mechanism, to extend to 700KST Series.

- Stitch Length Adjustment: Push-button
- Differential Feed Ratio Adjustment: Lever type
- Lubrication: Fully-automatic

700KT

													選購配件 OPTIONAL DEVICE
一般包縫 General Sewing	737KT-504M-3-0□	1	3	-	4,5	0.7~2.0	1~6	3.2	5	#9	7000	VT	
	747KT-514M-3-2□	2	4	2	3,4,5	0.7~2.0	1~6	3.2	5	#11	6700	VT	
折景車縫 Shirring/Gathering	747KT-514H-3-2□	2	4	2	3,4,5	0.7~2.0	1~8	3.2	6	#11	6300	VT,GA	
鬆緊帶車縫 Tape Attaching	747KT-514H-4-2□	2	4	2	3,4,5	0.7~2.0	1~8	3.2	6	#11	6300	VT	
一般包縫 General Sewing	757KT-516M-3-3□	2	5	3	4,5	0.7~2.0	1~6	3.2	6	#14	6700	CT	
	757KT-516M-3-5□	2	5	5	5,6	0.7~2.0	1~6	3.2	6	#14	6700	CT	
鬆緊帶車縫 Tape Attaching	757KT-516H-3-5□	2	5	5	5,6	0.7~2.0	1~7	3.2	7	#21	6300	CT,GA	
特厚布 Extra Heavy	757KT-516X-3-5□ ※	2	5	5	6,7	0.7~2.0	1~7	3.2	8	#21	5500	CT	

※ 搭配厚料修布角刀
With heavy material angle knife.

OVERLOCK STITCH

700K

747 K - 514 M 2 - 2 4 / VT / DKK□

機種別 Model
 K 一般型高速包縫/安全縫
 General Type High Speed
 Overlock/ Safety Stitch

送具型式
 Feed dog type

配件
 Device

線數
 Thread numbers

737	: 3T
747	: 4T
757	: 5T
767	: 6T

縫合方式
 Sewing types

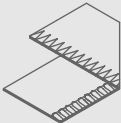
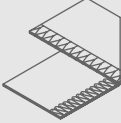
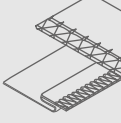
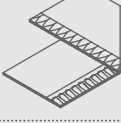
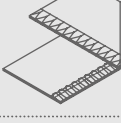
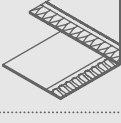
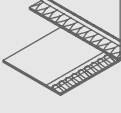
503	
504	
505	
512	
514	
516	
514 + 401	

針距
 Needle gauge

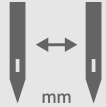

包邊寬度
 Overedge width



車縫布料
 Sewing fabric

F	輕薄布料 Fine weight fabric
L	薄布料 Light weight fabric
M	中厚布料 Medium weight fabric
H	厚布料 Heavy weight fabric
X	特厚布料 Extra heavy weight fabric

直驅伺服馬達
 Direct-drive servo motor

DKK□ 700K/700KST/700KS/700KT型直驅電控組
 Direct-Drive Servo Motor for 700K/700KST/
 700KS/700KT
 請參閱 P.49 Detail on Page.49



Energy saving 節能省電

Low temperature rising 溫升低

Good insulation 絕緣良好

700K/DKKU1

700K 系列包縫機配備直驅伺服馬達

Overlock machine with Direct-Drive Servo Motor



Feature 特點

- | | |
|--------------------|---|
| 1. 馬力強，同時又節能省電 | 1. Powerful while energy saving. |
| 2. 溫升高，安全絕緣良好 | 2. Low temperature rising, and safety with good insulation. |
| 3. 與 700K 之規格與配件相容 | 3. Compatible with 700K in specifications and accessories. |

控制器 Controller	配件 Device	電眼切刀 Sensor Trimmer	抬壓腳 Presser Foot Lifter	吸風集塵組 Air Suction Set	操作面板 Control Panel	針板 Needle Plate
DKKU□-0 經濟型 Economic Type	700K 相容配件 700K Compatible device		選配 / Optional TUA-32K	選配 / Optional TUA-31, 32K		標準型 Standard
DKKU□-1 多功能型 Multi-function Type	ECA-U		氣動 Pneumatic	氣動 Pneumatic		標配 Included
	ECB-U	電動 Electric	電動 Electric			
	VTE-U	吸風切線 Suction Trimmer	氣動 Pneumatic			
	CTE	吸風切線 Suction Trimmer	氣動 Pneumatic			



700K SERIES FEATURES



密封式直接傳動針棒專利機構

- 密閉針棒室，防塵防鏽汗滲入，避免漏油
- 縫製動能沿針棒運動方向直接傳達，有效提升縫紉高速化及耐久性；避免連杆式針棒之傳動耗損

Sealed type direct drive needle bar mechanism

- Dust free and oil-leakage-free are due to entirely sealed needle bar section design.
- Direct drive needle bar system leads to high speed and long durability.No driving loss of connecting-rod-drive needle bar system.



全新強制供油/回油及濾油系統

針棒，上勾針機構採用強制給油及全密閉式真空回油機構，完全排除以油線供油或滴落式供油產生問題

Active lubrication system

Needle bar and upper looper mechanisms are applied active oil supply and entirely sealed vacuum oil return system. The new system exceeds the traditional oil supply of rope type and dropping type.



專利雙刮雙唇式送具防漏設計

除雙刮板外又新增雙唇式刮板，阻油防油效果較原有雙刮板設計效果更佳

Patented feed dog mechanism oil proof system

New double-lip type wiper is added to support the original double wiper. Oil proof function is upgraded.



直接傳動式送具機構

直接傳動可防止差動輸送過度，縫紉更準確順暢，不用調整差動齒，避免連杆式送具之傳動耗損

Direct drive feeding mechanism

Direct drive mechanism prevents overdoing of differential feeding. No need to adjust the differential feed dog. No drive loss of connecting rod and type feeding mechanism.



新型切刀機構

刀座軸心低式設計，可防止面料回推現象，使面料切斷時不會產生捲邊現象

New fabric trimmer mechanism

Low axis knife holder prevents cloth rolls up after trimming.



專利一體化內藏式照明 (選購)

LED燈內藏一體化設計，穿線、目視操作方便，整體美觀

Patented integrated built-in lighting (Optional)

- Integrated built-in LED light design is artistic and user friendly.



可選配專用送具車縫超薄布料

例如: D201與H201標準品齒距為1.6mm ; D201A與H201A選購品齒距為0.8mm ; D201B與H201B選購品齒距為1.0mm

Feed dog for extra light weight fabric (Optional)

E.g.: D201 & H201(standard): Teeth spacing 1.6mm; D201A & H201A(optional): Teeth spacing 0.8mm; D201B & H201B(optional): Teeth spacing 1.0mm.



可選配短壓具舌車縫厚布料或長壓具舌車縫薄布料，讓車縫線跡更加完美

Optional presser foot fingers for better sewing performance: short finger for heavy fabric, long finger for light fabric.



更多便於使用的特點...

- 免開蓋針高調整，操作便利
- 下勾針座前後微調機構，維修省時簡易
- 環縫微調機構，開後蓋調粗細針，迅速省時
- 針板出線槽設計，包縫/環縫出線線圈更柔軟完美
- 車頭高度達5cm使進出布更加方便

More user friendly features:

- Needle bar height adjustment without opening machine.
- Lower looper holder fine tune mechanism.
- Chainstitch fine tune mechanism: Open the rear cover to adjust stitch length easily.
- Needle plate thread groove leads to perfect loop.
- 5 cm height sewing area offers better cloth movement.

																Remark
737K-503M2-04	1	3	-	4	0.7-2	3.6	6	DCX27#11	7500	A						
737K-504F1-04	1	3	-	4	0.7-2	3.6	6	DCX27#11	7500							
737K-504M2-04	1	3	-	4	0.7-2	3.6	6	DCX27#11	7500							
737K-504M3-04	1	3	-	4	0.7-2	3.6	6	DCX27#11	7500	B						
737K-504M3-05	1	3	-	5	0.7-2	3.6	6	DCX27#11	7500	B						
747K-514F1-24	2	4	2	4	0.7-2	3.6	5.5	DCX27#11	7500							
747K-512M1-25	2	4	2	5	0.7-2	3.6	5.5	DCX27#11	7500	D						
747K-512M1-34	2	4	3	4	0.7-2	3.6	5.5	DCX27#11	7500	D						
747K-514M2-24	2	4	2	4	0.7-2	3.6	5.5	DCX27#11	7500	C						
747K-514M2-25	2	4	2	5	0.7-2	3.6	5.5	DCX27#11	7500	C						
747K-514M2-28	2	4	2	8	0.7-2	3.6	4	DCX27#11	7500							
747K-514M4-23	2	4	2	3	0.7-2	3.6	6	DCX27#11	7500							
757K-516L1-24	2	5	2	4	0.7-2	3.6	6	DCX27#14	7500							
757K-516L1-35	2	5	3	5	0.7-2	3.6	6	DCX27#14	7500							
757K-516M2-35	2	5	3	5	0.7-2	3.6	6	DCX27#14	7500							
757K-516M2-55	2	5	5	5	0.7-2	3.6	6	DCX27#14	7500							
767K-516M2-324	3	6	3+2	4	0.7-2	3.6	6	DCX27#11	7000	E						
767K-516M2-524	3	6	5+2	4	0.7-2	3.6	6	DCX27#11	7000	E						
737K-504F1-04/DKK□	1	3	-	4	0.7-2	3.6	6	DCX27#11	7500							
737K-504M2-04/DKK□	1	3	-	4	0.7-2	3.6	6	DCX27#11	7500							
737K-504M3-04/DKK□	1	3	-	4	0.7-2	3.6	6	DCX27#11	7500	B						
737K-504M3-05/DKK□	1	3	-	5	0.7-2	3.6	6	DCX27#11	7500	B						
747K-514F1-24/DKK□	2	4	2	4	0.7-2	3.6	5.5	DCX27#11	7500							
747K-512M1-25/DKK□	2	4	2	5	0.7-2	3.6	5.5	DCX27#11	7500	D						
747K-512M1-34/DKK□	2	4	3	4	0.7-2	3.6	5.5	DCX27#11	7500	D						
747K-514M2-24/DKK□	2	4	2	4	0.7-2	3.6	5.5	DCX27#11	7500	C						
747K-514M2-25/DKK□	2	4	2	5	0.7-2	3.6	5.5	DCX27#11	7500	C						
747K-514M2-28/DKK□	2	4	2	8	0.7-2	3.6	4	DCX27#11	7500							
747K-514M4-23/DKK□	2	4	2	3	0.7-2	3.6	6	DCX27#11	7500							
757K-516L1-24/DKK□	2	5	2	4	0.7-2	3.6	6	DCX27#14	7500							

											Remark
757K-516L1-35/DKK□	2	5	3	5	0.7-2	3.6	6	DCX27#14	7500		
757K-516M2-35/DKK□	2	5	3	5	0.7-2	3.6	6	DCX27#14	7500		
757K-516M2-55/DKK□	2	5	5	5	0.7-2	3.6	6	DCX27#14	7500		
767K-516M2-324/DKK□	3	6	3+2	4	0.7-2	3.6	6	DCX27#11	7000	E	
767K-516M2-524/DKK□	3	6	5+2	4	0.7-2	3.6	6	DCX27#11	7000	E	



737K-504M3-04



747K-514M2-24



757K-516M2-35



767K-516M2-324



504



514



512

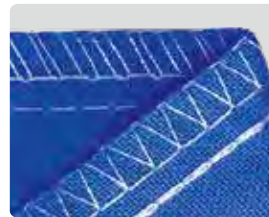

516



401+514

一般包縫

適用於特薄至中厚布料之包縫

GENERAL SEAMING

For regular seaming on light to medium fabric.

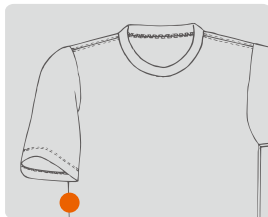

Remark

A: 上勾針為盲勾針

B: 單排送具

C: 適用於薄至中厚布料之包縫

D: 用於薄至中厚布料之一般縫合 (假五線)

E: 適用於薄至中厚布料之一般縫合 · 適合小量生產的打樣室或工作室選用 · 可由勾針及針之變換車縫出5種不同的縫合方式 (504,514,516, 401, 514+401)

A: Upper looper is blind looper

B: Single row feed dog

C: For regular seaming on light to medium fabric.

D: Mock 516 seaming

For regular seaming on light to medium fabric.

E: For regular seaming on light to medium fabric.

Specially suitable for small production workshop, and fashion design studio. A variety of five different sewing types by changing number of needle and looper.

(504, 514, 516, 401, 514+401).

選購配件 OPTIONAL DEVICE

VT, CSA, CSB, TUB

										Remark
737K-504F2-02/GAL	1	3	-	2	0.7-2	3.6	5.5	DCX27#9	7500	A
737K-504F1-15	1	3	-	1.5	0.7-2	3.6	5.5	DCX27#9	7500	B
737K-504M1-15	1	3	-	1.5	0.7-2	3.6	6	DCX27#9	7500	C
737K-504F2-02/GAL/DKK□	1	3	-	2	0.7-2	3.6	5.5	DCX27#9	7500	A
737K-504F1-15/DKK□	1	3	-	1.5	0.7-2	3.6	5.5	DCX27#9	7500	B
737K-504M1-15/DKK□	1	3	-	1.5	0.7-2	3.6	6	DCX27#9	7500	C



737K-504F2-02/GAL



737K-504F1-15



737K-504M1-15



A

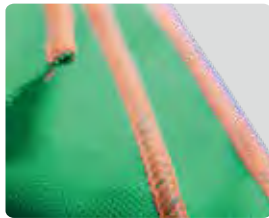

B



C

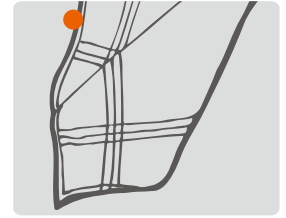
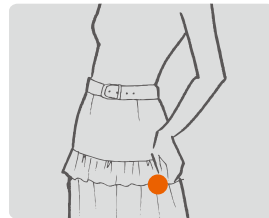

Remark

細包縫









- A.適用於特薄布料之捲邊細包縫 (荷葉邊) 例如: 手帕、禮服等
- B.適用於特薄布料之捲邊細包縫 (手帕邊包縫) 例如: 絲綢類布料之手帕、禮服等
- C.適用於薄至中厚布料之細包縫 (手帕邊包縫) 例如: 手帕、禮服等

FINE EDGING

- A. For fine edging on extra light knit fabric. The presser foot is with fine folding function. (falbala edging)
Eg : Handkerchief & dress...etc.
- B. For fine edging on extra light knit fabric. The presser foot is with fine folding function. (handkerchief edging)
Eg : Handkerchief & dress of silk fabric...etc.
- C. For fine edging on light to medium fabric. (handkerchief edging)
Eg : Handkerchief & dress ...etc.

選購配件 OPTIONAL DEVICE
VT, CSA, CSB, TUB

K3

									
747K-514M2-24/TG	2	4	2	4	0.7-2	3.6	6	DCX27#11	7500
747K-514M2-25/TG	2	4	2	5	0.7-2	3.6	6	DCX27#11	7500
747K-514M2-24/TG/DKK□	2	4	2	4	0.7-2	3.6	6	DCX27#11	7500
747K-514M2-25/TG/DKK□	2	4	2	5	0.7-2	3.6	6	DCX27#11	7500



747K-514M2-24/TG/EC

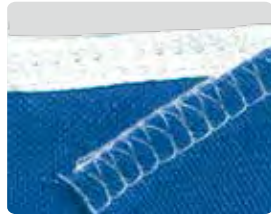

肩帶包縫

適用於針織衣服如T恤·毛衣等之肩部多車一條織帶·可防止衣服肩部變形

TAPE INSERTING

For sewing a woven tape onto the shoulder of knitwear such as T-shirt or sweater etc., to prevent abnormal stretching.

選購配件 OPTIONAL DEVICE
EC, LFA, LS

K4

									
737K-505F1-04	1	3	-	4	0.7-2	3.6	6	DCX27#9	7500
737K-505F1-04/DKK□	1	3	-	4	0.7-2	3.6	6	DCX27#9	7500



737K-505F1-04



拷下擺

用於特薄至薄布料之針織T恤·內衣等之下擺或袖口拷縫

BLIND HEMMING

For hemming sleeves and bottoms of T-shirts or underwear etc. Applicable for light to extra light fabric.

特殊效果：上勾針改用LP231盲勾針·可以露出針線

Special effect : replace upper looper by blind looper, LP231, the needle thread can be shown on the surface.

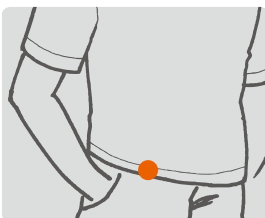

選購配件 OPTIONAL DEVICE
VT, CSA, CSB, TUB



737K-504M2-04/LFC-3	1	3	-	4	0.7-2	3.6	6	DCX27#11	7000
747K-514M2-2□/LFC-3	2	4	2	4,5	0.7-2	3.6	6	DCX27#11	7000
747K-514M2-2□/ SMK	2	4	2	4,5	0.7-2	3.6	6	DCX27#11	7000
737K-504M2-04/TR	1	3	-	4	0.7-2	3.6	6	DCX27#11	7500
737K-504M2-04/TR/DKK□	1	3	-	4	0.7-2	3.6	6	DCX27#11	7500



747K-514M2-24/ SMK



747K-514M2-24/LFC-3



737K-504M2-04/TR



LFC-3

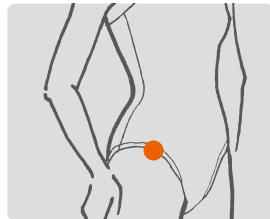

TR

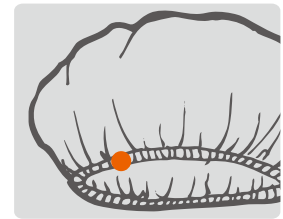

鬆緊帶車縫

利用送帶裝置控制鬆緊帶之張力，適用於泳衣、內衣褲或運動服飾之鬆緊帶包縫

LFC-3：機械式送帶

多樣的壓腳可供選擇

SMK：電子計數式送帶

SMK1-A-01 附定位器，適合簡易伺服或離合器馬達

SMK1-A-02 以中繼線，連接伺服馬達

ELASTIC ATTACHING

Tape feeding device controls the tension. Applicable to swimming wear, underwear, sports wear's elastic band attaching.

LFC-3 : Mechanic type elastic tape feeding various presser feet for optional demand.

SMK: Electric metering type elastic tape feeding

SMK1-A-01 with synchronizer for simple servo motor or clutch motor

SMK1-A-02 Connected to servo motor by encoder cable

	壓具 Presser foot	鬆緊帶寬度 Band width	備註 Remark
737K	P216-3	2mm~13mm	標配 Standard
747K	P216-4	2mm~13mm	標配 Standard
	P217-4	Max. 20mm	選配 Optional
	P218-4	Max. 30mm	選配 Optional
	P219-4	Max. 35mm	選配 Optional

TR:簡易鬆緊帶車縫(浴帽車縫)

利用彈簧片調整，控制鬆緊帶之鬆緊程度，可簡易進行鬆緊帶之包縫，適用於不織布、塑膠布等浴帽或醫療用衣物
例如：浴帽、醫療用衣物等

TR:SIMPLE ELASTIC ATTACHING

For attaching elastic tape on non-woven or plastic cloth. The tension is controlled by spring.

Eg : Shower cap, medical clothing...etc.

選購配件 OPTIONAL DEVICE
EC, LFA, LS

K6



	2	4	2	4	0.7-2	3.2	5.5	DCX27#11	7500
747K-514H4-24/GA	2	4	2	4	0.7-2	3.2	5.5	DCX27#11	7500
757K-516H4-35/GA	2	5	3	5	0.7-2	3.6	6	DCX27#14	7000
757K-516H4-55/GA	2	5	5	5	0.7-2	3.6	6	DCX27#14	7000
747K-514H4-24/GA/DKK□	2	4	2	4	0.7-2	3.2	5.5	DCX27#11	7500
757K-516H4-35/GA/DKK□	2	5	3	5	0.7-2	3.6	6	DCX27#14	7000
757K-516H4-55/GA/DKK□	2	5	5	5	0.7-2	3.6	6	DCX27#14	7000



747K-514H4-24/GA



757K-516H4-35/GA/CT



GA



GA/CT

折景車縫

適用中厚布料下層布間歇或連續性不規則折景車縫，可加滾邊喇叭增加車縫品質如裙子，床罩，窗簾等

注：P布條滾邊喇叭（入布寬度25mm，出布寬度6mm）

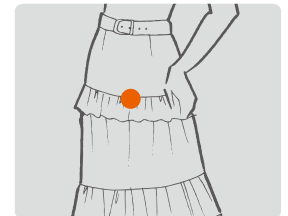

GATHERING

Continuous or intermittent random gathering on lower ply of medium fabric, can be equipped with piping folder to increase sewing quality for shirt, bed sheets, curtains etc.

Remark : P: Piping folder (tape width 25mm, finished size 6mm)

選購配件 OPTIONAL DEVICE
EC . P(KV57-A) , FG , VT ,CT , CSA , CSB , TUB

										
手動 Manual	737K-504M5-04/BK(BK-1)	1	3	-	4	0.7-2	3.6	6	DCX27#11	7000
	747K-514M5-2□/BK(BK-1)	2	4	2	3,4	0.7-2	3.6	6	DCX27#11	7000
	747K-514M7-2□/BK(BK-1)	2	4	2	4,5	0.7-2	3.6	7	DCX27#11	7000
	737K-504M5-04/BK(BK-1)/DKK□	1	3	-	4	0.7-2	3.6	6	DCX27#11	7000
	747K-514M5-2□/BK(BK-1)/DKK□	2	4	2	3,4	0.7-2	3.6	6	DCX27#11	7000
	747K-514M7-2□/BK(BK-1)/DKK□	2	4	2	4,5	0.7-2	3.6	7	DCX27#11	7000
半自動 Semi-Auto	747K-514M5-23/BKS/DKK□	2	4	2	3	0.7-2	3.6	6	DCX27#11	7000
	747K-514M7-24/BKS/DKK□	2	4	2	4	0.7-2	3.6	7	DCX27#11	7000
簡易式全自動 Simplified Fully Auto	737K-504M5-04/ECB/BKT/DKK□	1	3	-	4	0.7-2	3.6	7	DCX27#11	7000
	747K-514M2-24/ECB/BKT/DKK□	2	4	2	4	0.7-2	3.6	7	DCX27#11	7000
全自動 Fully Auto	737K-504M5-0□/BKF	1	3	-	3,4,5	0.7-2	3.6	7	DCX27#11	7000
	747K-514M5-2□/BKF	2	4	2	3,4	0.7-2	3.6	7	DCX27#11	7000



737K-504M5-04/BK



747K-514M5-23/BKS



747L-514M-3-24/ECA/BKT



747K-514M5-23/BKF



線頭包縫

將線頭包入車縫線內，可防止縫合之開口處縫線脫落，適用於內衣褲、運動服之袖口及側邊縫合

BACK LATCHING SEAMING

To prevent seam looseness, turn over the thread and then insert into overlock seaming at the beginning of sewing. For sleeve and sideways sewing of underwear, sportswear etc.

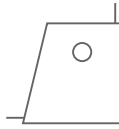
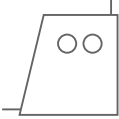
操作 Operation	配件代號 Code	說明 Description	適用機頭 Applicable Series	驅動方式 Drive Type
手動 Manual	BK	Rotary Plate 	737K 747K 737L 747L	建議搭配伺服馬達， 使用定針功能， 提升車縫效率 To equip with servo motor for needle position function is optional and recommended.
	BK-1	Fixed Plate 		
半自動 Semi-Auto	BKS	4線拷克專用，針板舌自動伸縮 4 Thread overlock applicable, Needle plate tongue Auto-retracted	747K	腳踏板氣閥控制 氣動式 Pedal valve control Pneumatic type
簡易式全自動 Simplified Fully Auto	BKT	1. 簡易式，線頭長度約3cm 2. ECA切刀，針板有特殊風道設計，線頭向下吸回 1. Simplified type, back latch length 3cm. 2. With ECA cutter, Needle plate suction channel for thread-end down turning.	737K 747K 737L 747L	700K電控系統 氣動式 700K: Control system Pneumatic type
自動 Fully Auto	BKF	1. VT吸風切線 2. 可設定多種操作模式 3. 線頭側向吹回，長度可以調整(最短1cm) 1. With VT suction trimmer 2. Multi-operation mode setting 3. Thread-end side turning. Back latch length is adjustable (Min. 1cm)	737K 747K 737L 747L	賀欣 i70直驅馬達 氣動式 Hohsing i70 Servo Motor Pneumatic type

K8



	2	4	2	4	0.7-2	3.6	7	DCX27#16	7500
747K-514M7-24	2	4	2	5	0.7-2	3.6	7	DCX27#16	7500
747K-514M7-25	2	5	5	6	0.7-2	3.6	6	DCX27#18	7500
747K-514M7-24/TG	2	4	2	4	0.7-2	3.6	7	DCX27#16	7500
747K-514M7-25/TG	2	4	2	5	0.7-2	3.6	7	DCX27#16	7500
747K-514M7-24/DKK□	2	4	2	4	0.7-2	3.6	7	DCX27#16	7500
747K-514M7-25/DKK□	2	4	2	5	0.7-2	3.6	7	DCX27#16	7500
747K-514M7-24/TG/DKK□	2	4	2	4	0.7-2	3.6	7	DCX27#16	7500
747K-514M7-25/TG/DKK□	2	4	2	5	0.7-2	3.6	7	DCX27#16	7500



747K-514M7-24



747K-514M7-24/TG/EC



757K-516X2-56

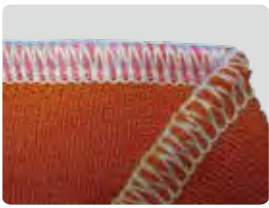

TG/EC

厚毛衣料肩帶包縫

適用於毛衣之肩部多包縫一條平織布條，可防止衣服肩部變形
注：布條裝置之導板使用，布條最大寬度為1/4"(6.35mm)

TAPE INSERTING ON BULKY KNITWEAR

For sewing a woven tape onto the shoulder of knitwear such as sweater, to prevent abnormal stretching.

Remark: Max. width of tape is 1/4"(6.35mm)

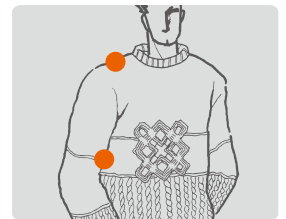

TG/EC 選購配件 OPTIONAL DEVICE

EC, AN, LFA, LS



514M7

厚毛衣料包縫

適用於粗厚毛線衣物車縫

OVER SEAMING ON BULKY KNITWEAR

For regular seaming on bulky knit fabric such as sweater.

514M7 選購配件 OPTIONAL DEVICE

AN, CT, CSA, CSB, TUB



516X2

薄牛仔包縫

特殊傳動行程結構適用於薄牛仔布料之包縫，例如：牛仔布 & 工作服

LIGHT DENIM OVERLOCK

Special driving mechanism for seaming on light denim fabric such as jeans, workwears etc.



516X2 選購配件 OPTIONAL DEVICE

CT, CSA, CSB, TUB



757K-516M2-35/PS	2	5	3	5	0.7-2	3.6	6	DCX27#14	7000
757K-516M2-55/PS	2	5	5	5	0.7-2	3.6	6	DCX27#14	7000
757K-401M2-50/TA	2	4	5	-	0.7-2	3.6	6	DCX27#14	7000
757K-516M2-35/PS/DKK□	2	5	3	5	0.7-2	3.6	6	DCX27#14	7000
757K-516M2-55/PS/DKK□	2	5	5	5	0.7-2	3.6	6	DCX27#14	7000
757K-401M2-50/TA/DKK□	2	4	5	-	0.7-2	3.6	6	DCX27#14	7000



757K-516M2-35/PS



757K-401M2-50/TA

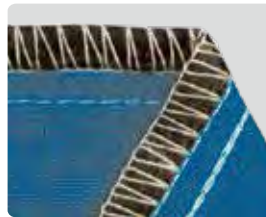

PS



TA

口袋邊包縫

PS: 在褲袋邊緣多上一包邊布條，以強化縫合處，增加美觀

注：標準喇叭之入布寬度為3/8"(9.5mm)

TA: 雙勾針機型，適用於褲袋邊緣加包邊布條，並車縫兩道環縫線以強化縫合處增加美觀

注：標準喇叭(入布寬度25.4mm/出布寬度6.4mm)



POCKET BINDING

PS: To insert an extra tape to cover on the edge of pocket then by safety stitching for strengthening the pocket seaming. Suitable for high quality trousers.

Remark: Standard folder for tape width is 3/8"(9.5mm)

TA: Two needle two chainstitches. Tape binding by two chainstitch on the edge of pocket of high quality trousers.

Remark: Standard folder (tap width 25.4mm/finish width 6.4mm)

選購配件 OPTIONAL DEVICE

EC . FG

K10



	1	3	-	-	-	-	-	DCX27#11	7500
737K-WR/LFC-3	1	3	-	5	0.7-2	3.6	6	DCX27#14	7500
737K-504M3-05/PZ	1	2	-	-	0.7-2	3.6	5.5	DCX27#14	7000
757K-401M1/TW	1	3	-	5	0.7-2	3.6	6	DCX27#14	7500
737K-504M3-05/PZ/DKK□	1	2	-	-	0.7-2	3.6	5.5	DCX27#14	7000



737K-WR/LFC-3



737K-504M3-05/PZ



757K-401M1/TW



LFC-3

管狀布條車縫

將針織布條拷邊車縫後再反條成管形，適用於各種泳裝，睡衣或韻律服等管狀肩帶
 注：標準喇叭之布條入布寬度22mm(7/8") 成型之管狀布條直徑為5mm

SPAGHETTI SEWING

To sew knit fabric tape and turn over it into spaghetti tube for swimwears, nightgowns etc...
 Remark : Standard folder specification: tape width is 22mm (7/8") and the finished tube size is about 5mm in diameter.

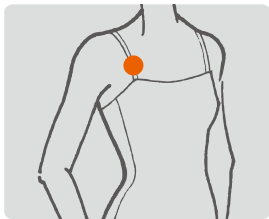

選購配件 OPTIONAL DEVICE
FG



PZ

拉鍊包縫

適用於薄布料之拉鍊包縫，可將拉鍊與衣身裁片同時包縫

ZIP SEAMING

For regular seaming for zipper with light fabric.



選購配件 OPTIONAL DEVICE
VT, CSA, CSB, TUB

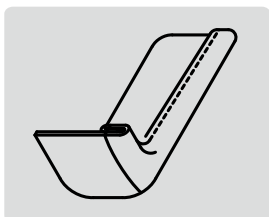

TW

毛巾布邊車縫

本機為單針單勾針機型，適用於毛巾布邊之車縫

TOWEL EDGING

This is a single needle, single looper machine, suitable for towel sewing.

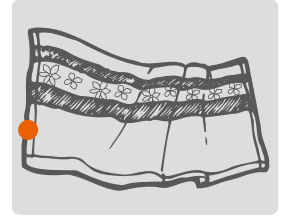

選購配件 OPTIONAL DEVICE
CT, CSA, CSB, TUB

DEVICE



AN

角刀 Angle Knife

修布輔助，對於厚料之修布更順暢
Cloth trimming assistance to heavy material.

可自行組裝 self-installation : YES
適用機型 applicable model : 700K Series(for heavy material), 700L/LX Series(for heavy material)



**BK
BK-1**

包線頭裝置 Back Latching

將線頭一起包入車縫，可防止縫合開口處(如袖口)之縫線脫落
· KD207手輪: 訂機頭有裝此零件以配合定針用，若個別訂購BK組則依需要訂購
· 包含BK232車布導板

To prevent seam looseness, turn over the thread and then insert into overlock seaming at the beginning of sewing.

· KD207 hand wheel: standard equipment of 700K/BK machine, optional for BK device.
· Including BK232 sewing bed .

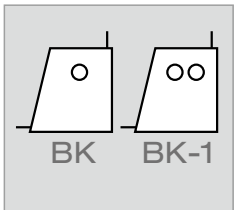

可自行組裝 self-installation : YES
適用機型 applicable model : 737K-504M5, 747K-514M5, 747K-514M7, 737L-504M7,
747L-514M7, 747L-514H7



BKS

半自動包線頭系統 Semi-Automatic Back Latch System

本裝置可精準控制抬壓腳，鬆線，與針板舌動作，線頭包縫起點緊密牢固不鬆脫，實現高品質的縫製需求

This device precisely controls the movements of presser foot, thread releasing, and needle plate tongue. It makes the tight starting and achieves the requirement of sewing high quality.

可自行組裝 self-installation : YES
適用機型 applicable model : 747K-514M5, 747K-514M7



CSA

鐵桶式吸風馬達 Iron Case Suction Device

1. 雙吸馬力足(前後吸)，連接在車頭上比同類馬達大1/4的馬力(後吸為切刀，前為漏斗式吹氣)
2. 噪音低，可比同類馬達降低 5dB
3. 溫度低，可比同類馬達降溫18%
4. 節省空間，裝在車板下比同類馬達節省10%的體積
5. 容易安裝，可比同類馬達少1/2 安裝時間
6. 清理順暢，拆裝容易，集塵無漏洞
7. 風壓可視需求調整大小

1. Two-way suction (rear and front suction). 1/4 HP more than normal standard. (Rear suction is for thread trimmer, front suction is for fabric waste).
2. Quiet. 5dB lower than normal standard.
3. Low temperature. 18% celsius lower than normal standard.
4. Space efficiency. 10% space saved than normal standard.
5. Easy assembly. 50% time saved for assembly.
6. Easy to clean, easy to assemble/disassemble, completed dust collection.
7. Air pressure can be adjusted as required.

可自行組裝 self-installation : YES

適用機型 applicable model : MODEL w/CT, MODEL w/DT, MODEL w/VT



CSB

塑膠筒式吸風馬達 Plastic Tank Suction Device

1. 單吸馬力足 · 裝在車頭上比同類馬達大1/4的馬力(適用後吸切刀)
 2. 噪音低 · 可比同類馬達降低 5dB
 3. 溫度低 · 可比同類馬達降溫10%
 4. 節省空間 · 裝在車板下比同類馬達節省25%的體積
 5. 容易安裝 · 可比同類馬達少1/4 安裝時間
 6. 清理順暢 · 拆裝容易 · 集塵無漏洞
 7. 風壓可視需求調整大小
1. One-way suction, 1/4 HP more than normal standard. (for rear suction thread trimmer)
 2. Quiet, 5dB lower than normal standard.
 3. Low temperature. 10% lower than normal standard.
 4. Space efficiency. 25% space saved than normal standard.
 5. Easy assembly. 25% time saved for assembly.
 6. Easy to clean, easy to assemble/disassemble, completed dust collection.
 7. Air pressure can be adjusted as required.

可自行組裝 self-installation : YES

適用機型 applicable model : MODEL w/CT, MODEL w/DT, MODEL w/VT



CT

水平式自動吸風切線裝置 Horizontal Pneumatic Type Chain Cutter (Flat Suction)

利用吸風式馬達或空壓機 · 將線吸入切刀槽中予以切斷(較適用於4~6線之機型)
Take thread into trimmer tube by suction motor or air compressor.
(Applicable for 4~6 thread machine)

可自行組裝 self-installation : YES

適用機型 applicable model : 747K, 757K, 767K, 747L/LX, 757L/LX, 767L/LX



CTE

水平式吸風切線 (附電眼節能裝置) Flat Suction Chain-Cutter(With Sensor-Controlled Energy-Saving Device)

電控系統支援電眼節能裝置 · 採用電眼偵測布邊 · 利用控制箱調整旋鈕 · 控制吸風功能在切線時運作 · 減少空壓設備的能源消耗 · 並避免縫線浪費

Computerized system drives sensor-controlled energy saving device. Electric eye (sensor) checks the fabric edge. Turn the button of control box to set the time of air suction of chain-cutter. It saves the energy consuming of air compressor system and also saves thread consuming.

可自行組裝 self-installation : NO

適用機型 applicable model : 747K, 757K, 767K, 747L/LX, 757L/LX, 767L/LX



DKL 12 DKK 12

直驅伺服馬達 Direct-drive Servo Motor

包縫機模組化搭配直驅伺服馬達，多樣化的選擇，更有彈性

1=廠商代碼 2=版本代碼 + 功能代碼

Overlock machine equipped with the modularized direct-drive servo motors to be more flexible for diversification.

1=Manufacturer code 2=Version code + Function code

可自行組裝 self-installation : YES

適用機型 applicable model : 全系列包縫機 All Overlock Series



EC

電動式切布條/鬆緊帶條裝置 Electric Type Tape / Elastic Cutter

利用手動按鈕方式切斷鬆緊帶，不織布條或滾邊布條

1. 標準切刀 EC-K (16 mm) · 長切刀 EC-K-A (22 mm)

2. 標準為手動切帶，另可選購膝控切帶 (FEC34-A)

Cuts tape/ elastic by pressing the button.

1. EC-K: Standard knife (16 mm") EC-K-A: Long knife (22 mm")

2. Hand-control button : standard Knee-control paddle (FEC34-A) : Optional

可自行組裝 self-installation : YES

適用機型 applicable model : MODEL w/GA/P, MODEL w/LFC-3, MDDEL w/PS, MODEL w/TA, MODEL w/TG, MODEL w/TR



ECA ECB

氣動式切刀 (自動模式切換功能/附手動)

Pneumatic Type Tape / Thread Cutter (With Auto / Manual Switch Function)

電動式切刀 (自動模式切換功能/附手動)

Solenoid Type Tape / Thread Cutter (With Auto / Manual Switch Function)

電眼在偵測到車縫完畢時精準下刀。ECA為氣動式，ECB為電動式，搭配吸風線槽，操作更順暢

Advanced sensor inspects the completion of sewing work and initiates cutting without time lag. ECA is pneumatic type, and ECB is electric type, compatible with air suction slot, which makes the operation more smoothly.

	雙電眼 Dual Sensor	切刀 Cutter	氣動配件Pneumatic Set			備註 Remark
			抬壓腳 Foot Lifter	吸風集塵組 Suction Set	吸風線槽 Suction Channel	
ECA	√	氣動 Pneumatic	√	√	√	全功能 Full Function
ECB-A	√	電動 Electric	√	√	√	全功能 Full Function
ECB	√	電動 Electric		X		經濟型 Economic

ECB適用: 無空壓設備之成衣廠，或短裁片不抬壓腳連續車縫作業

ECB Applicable for: Garment factory without air compressor, or Continually short sewing operation without presser foot lifting.

可自行組裝 self-installation : NO

適用機型 applicable model : 737K, 747K, 757K, 767K, 737L/LX, 747L/LX, 757L/LX, 767L/LX



ECA



ECB

**FG****側帶盤 Side Tape Holder**

置於桌板右側放布條用

For tape feeding, on the right side of the table.

可自行組裝 self-installation : YES

適用機型 applicable model : MODEL w/GA/P, MDDEL w/PS, MODEL w/TA

**GA****折景裝置 Gathering**

下層布間歇或連續性不規則折景

P滾邊器(喇叭)KV57(入布寬度25mm/出布寬度6mm)依需要可另訂，若滾邊加繩需另訂壓具(壓具底需磨一條溝)，為一般壓具代號多加P，如：P204P

Continuous or intermittent random gathering on lower ply.

P: Piping folder KV57 (tape width 25mm / finish width 6mm) is optional. For piping with rope inside, presser foot requires a trench, which is marked with P at the end of parts code. eg P204P.

可自行組裝 self-installation : YES

適用機型 applicable model : 747K-514H4, 757K-516H4, 747KT-514H,
747L/LX-514M8, 747L/LX-516M8**GAL****荷葉邊密拷裝置 Flounce/Falbala fine edging**

彈性布料密合時，以壓布杆向下壓住布料邊緣，形成向後拉力，而產生荷葉邊造型，可調整壓力產生不同的波浪效果

Elastic fabric fine serging with a pull-back device makes flounce/ falbala style. Adjust the pressure of pull-back plate to have big or small waves.

可自行組裝 self-installation : YES

適用機型 applicable model : 737K-504F2 , 737L/LX-504F2

**GB****前綜合送折景裝置 Gathering Device for Top Feed Model**

前綜合送上下層布間歇或連續性不規則折景

P滾邊器(喇叭)KV57(入布寬度 25mm / 出布寬度 6mm)依需要可另訂，若滾邊加繩需另訂壓具(壓具底需磨一條溝)，為一般壓具代號多加P，如：P463P

Continuous or intermittent random gathering on lower ply, for top feed model.

P: Piping folder KV57 (tape width 25mm / finish width 6mm) is optional. For piping with rope inside, presser foot requires a trench, which is marked with P at the end of parts code. e.g. P463P.

可自行組裝 self-installation : YES

適用機型 applicable model : 700KT

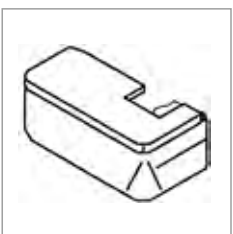
**KB561-A****平台式車布導板 Flat Bed Cloth Plate**

將筒型車改為平台式，方便於非筒型衣物包縫

To convert cylinder bed machine into flat bed machine. For normal overlock sewing operation.

可自行組裝 self-installation : YES

適用機型 applicable model : 700KS, 700KST



FA

側向電動送帶裝置 Side Electric Tape Feeding

1. 利用電子微動開關控制布條・鬆緊帶或蕾絲之輸送長度・使上帶車縫更加平順
2. 送帶在控制箱右邊

1. With electronic switch to control the feeding length of tape, elastic, or lace to create smoother sewing.
2. Tape feeding will be on the right hand side of the control box.

可自行組裝 self-installation : YES

適用機型 applicable model : 700K, 700L/LX



LFA-A□

電動式直向送帶裝置 Electric Type Upper Tape Feeding Device

利用電子馬達帶動鬆緊帶・使其放鬆到零鬆緊狀況・並可控制所需鬆緊帶之長短・使車縫時鬆緊度能一致

□代表電壓・1 : 110V・2 : 220V

To keep constant tension for sewing. Elastic tape is fed by motor for zero tension and required length.

□=voltage, 1: 110V, 2: 220V

可自行組裝 self-installation : YES

適用機型 applicable model : MODEL w/LFC-3, MODEL w/TG, MODEL w/TR



LF290-A□

抖帶輪 Untangle Wheel

可選配安裝於LFA (送帶裝置)・以逆轉的方式・抖動鬆緊帶・做為送帶前的處理

□代表電壓・1 : 110V・2 : 220V

An optional device to be equipped with LFA (tape feeding device). Untangling the elastic tape by reverse rotation wheel is a pre-feeding process.

□=voltage, 1: 110V, 2: 220V

可自行組裝 self-installation : YES

適用機型 applicable model : MODEL w/LFA



LFC-3

機械式鬆緊帶送帶裝置 Mechanical Type Elastic Feeding

利用齒輪調整控制鬆緊帶之鬆緊程度；壓具:分3線及4線用如：P216-3・P216-4 (標準品配P216除非下單時註明)

To Control elastic tape tension by adjusting the gear.

Presser foot:

P216-3 for 3 thread

P216-4 for 4 thread

Standard is P216. Special demand by request.

壓具代號 Presser Foot	P216	P217	P218	P219
鬆緊帶尺寸 Elastic Size	2-13mm	2-20mm	2-30mm	2-35mm

可自行組裝 self-installation : YES

適用機型 applicable model : 737K-504M2, 747K-514M2,
737L/LX-504M3, 747L/LX-514M3



LS 上方帶盤 Upper Tape Holder

置於上前方放布條或鬆緊帶
For top feeding tape or elastic.

可自行組裝 self-installation : YES

適用機型 applicable model : MODEL w/LFC-3, MODEL w/TG, MODEL w/TR



P(KV57) 折景滾邊喇叭 Piping Binder for Gathering

入布寬度 25 mm / 出布寬度 6 mm
Tape width 25 mm / Finish width 6 mm

可自行組裝 self-installation : YES

適用機型 applicable model : MODLE w/GA



PS 口袋包邊縫合裝置 Pocket Sewing

在褲袋邊緣多車上一包邊布條，以強化縫合處增加美觀
喇叭PS201:可用布條寬度為3/8" (9.5mm)

Overlock sewing with tape binding for strengthening the pocket edge.

PS201: Folder, for tape width 3/8" (9.5mm)

可自行組裝 self-installation : YES

適用機型 applicable model : 757K-516M2, 757L/LX-516M2



PZ 拉鍊車縫裝置 Zip Seaming

將拉鍊與衣身裁片同時包縫
Overlock sewing for joint between zipper and cloth.

可自行組裝 self-installation : YES

適用機型 applicable model : 737K-504M3, 737L/LX-504M3



UC 上下層防捲邊 Top and Bottom Anti-Curly Edge

針對易捲曲布料所開發的氣動裝置，在布料進入壓腳之前，將布料吹平，可適用外捲，內捲等各種捲曲的情形，大幅增加車縫效率

有三種版本可選搭: UC-L(高級電控式) · UC-L2(經濟機械式) · UC-L3(外捲單一式)

The pneumatic device solves the problem of curly edge material. The fabric edge is flattened by air before entering the presser foot. Applicable to up-roll, down-roll, and all kinds of curly edge situations, which highly improves the sewing efficiency.

There are 3 types for this device. UC-L (High-end electronic control type), UC-L2 (economic mechanical type), and UC-L3 (Up-roll only type).



UC-L2

可自行組裝 self-installation : YES

適用機型 applicable model : 700K Series, 700L/LX Series

**TA****雙勾針環縫口袋包邊縫合裝置 Two Chainstitch Pocket Sewing**

在褲袋邊加包邊布條並車兩道環縫線，以強化縫合處增加美觀，標準喇叭(入布寬度25.4mm/出布寬度6.4mm)

Tape binding by two chainstitch sewing for strengthening the pocket edge.
Standard folder(tape width 25.4mm/ finish width 6.4mm)

可自行組裝 self-installation : YES

適用機型 applicable model : 757K-401M2-50, 757L/LX-401M8-50

**TBK
TB-Q1****全沉式機頭安裝支撐組 Machine Body Supporter for Full Submerged Table**

全沉式桌板機頭支撐組

700K series machine base for full submerged table.

可自行組裝 self-installation : YES

適用桌板 applicable model : Table 700K-T1, Table 700Q-T1

**TG****車肩帶裝置 Tape Guide**

在車針織布時多車上一條平織布條，可防止肩部寬變型張開，壓具P254J-4A布條最大寬度為13mm

To prevent knit wear shoulder stretching, insert woven tape for strengthening.
P254J-4A: Presser foot for maximum tape width is 13 mm.

可自行組裝 self-installation : YES

適用機型 applicable model : 747K-514M2, 747K-514M7,
747L/LX-514M3, 747L/LX-514H4

**TR****簡易鬆緊帶控制組 Elastic Controller**

利用彈簧片簡易控制鬆緊帶鬆緊度，適合不織布或塑膠布浴帽車縫

Applicable for non-woven/ plastic shower cap sewing. Control the tension of elastic by the spring.

可自行組裝 self-installation : YES

適用機型 applicable model : 737K-504M2, 737L/LX-504M3

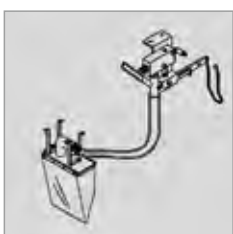
**TU****空氣閥 Venturi**

當踩腳踏板開始車縫時，空壓機所供給之壓縮空氣便會將車縫線吸入切刀槽中予以切斷，並使其線屑順著塑膠管吸入塑膠筒中

When stepped on the pedal for sewing, air from compressor vacuums the thread into the trimmer tube, and then the trimmer cuts the thread. Thread waste is collected by the tube.

可自行組裝 self-installation : YES

適用機型 applicable model : MODEL w/CT, MODEL w/DT, MODEL w/VT, Please Refer
Motor Page



TW

單針環縫(毛巾車)裝置 Towel Edging

適合車毛巾邊緣

Applicable for towel edge sewing.

可自行組裝 self-installation : YES

適用機型 applicable model : 757K-401, 757L/LX-401



VT

垂直吸風式自動切線裝置 Vertical Pneumatic Type Chain Cutter (Side Suction)

利用吸風馬達或空壓機將線吸入切刀槽中予以切斷(較適用於3~4線之機型)

Take thread into trimmer tube by suction motor or air compressor. (Applicable for 3~4 thread machine)

可自行組裝 self-installation : YES

適用機型 applicable model : 737K, 747K, 737L/LX, 747L/LX, 737KS, 747KS



VTE

垂直吸風切線 (附電眼節能裝置)

Side Suction Chain-Cutter (With Sensor-Controlled Energy)

電控系統支持電眼節能裝置·採用電眼偵測布邊·利用控制箱調整旋鈕·控制吸風功能在切線時運作·減少空壓設備的能源消耗·並避免縫線浪費

Our computerized system drives sensor-controlled energy saving device. Electric eye (sensor) checks the fabric edge. Turn the button of control box to set the time of air suction of chain-cutter. It saves the energy consuming of air compressor system and also saves thread consuming.

可自行組裝 self-installation : NO

適用機型 applicable model : 737K, 747K, 737L/LX, 747L/LX



**WR/
LFC-3**

管狀布條車縫裝置(反條裝置) Spaghetti Sewing

針織布條之拷邊車縫並反條成管形·適用於各種泳衣或睡衣、韻律服等之管形肩帶·喇叭布條寬度約22.2mm (7/8")·成型肩帶直徑5mm

Overlock sewing at knit tape edge and then turn it into tube. For swimwears, night gowns etc. Folder size: tape width is 22.2mm, finished tube size is 5mm in diameter.

可自行組裝 self-installation : YES

適用機型 applicable model : 737K, 737L/LX

TUX-3X

三合一吸風集塵組 / 3-in-1 Dust Collecting Suction Device

電眼機型(ECA, ECB, CTE, VTE)標準配備的吸風集塵組·可適用於700L/LX、700K、700KT/KS/KST系列·線屑(後吸風)、布屑(前吸風)、棉絮(內吸風)同時清除

Standard device of sensor-controlled machine (ECA, ECB, CTE, VTE), which cleans away thread ends (rear suction), cloth waste (front suction), and lint (inner suction). Compatible to 700L/LX, 700K, 700KT/KS/KST.

代號 Code	功能組件 Functional Section					適用機型 Applicable Series	備註 Remark
	三吸組 3-in-1 set	抬壓腳 Presser Foot Lifter	氣閥 Air Switch		濾瓶 Filter		
			機械式 Mechanical Type	電磁閥式* Solenoid Type			
TUA-31	●	/	單聯 Single way	/	/	700K / L / LX KS / KST / KT	
TUA-31-A							
TUA-32K	●	●	雙聯 Double ways	/	/	700K / L / LX	
TUA-32K-A		●	雙聯 Double ways	/	●		
TUA-33K		/	/	單聯 Single way	●		
TUA-34K		●	/	雙聯 Double ways	●		
TUA-32KT	●	●	雙聯 Double ways	/	/	700KT	
TUA-34KT		●	/	雙聯 Double ways	●		
TUA-37S	●	/	/	單聯 Single way	●	700KS / KST	需搭配開口型桌 板(72頁) Open type table required (Page.72)
TUA-38S		●	/	雙聯 Double ways	●		
TUA-39S		/	/	單聯 Single way	/		
TUA-40S		●	/	雙聯 Double ways	/		
TUA-38ST	●	●	/	雙聯 Double ways	●	700KST	
TUA-40ST		●	雙聯 Double ways	/	/		
TUA-41S	●	●	/	雙聯 Double ways	●	700KS / ESK	

* 備註: 電磁閥需由伺服馬達的電控箱驅動·接頭規格有8-Pin(賀欣MJ系列)與15-Pin(賀欣i系列)·TSA或簡易直驅系列不支援

* Remark: The solenoid must be driven by servo motor control box. The adapter spec. are 8-Pin (Hohsing MJ series) and 15-Pin (Hohsing iseries). TSA Series and Simply type are not applicable.

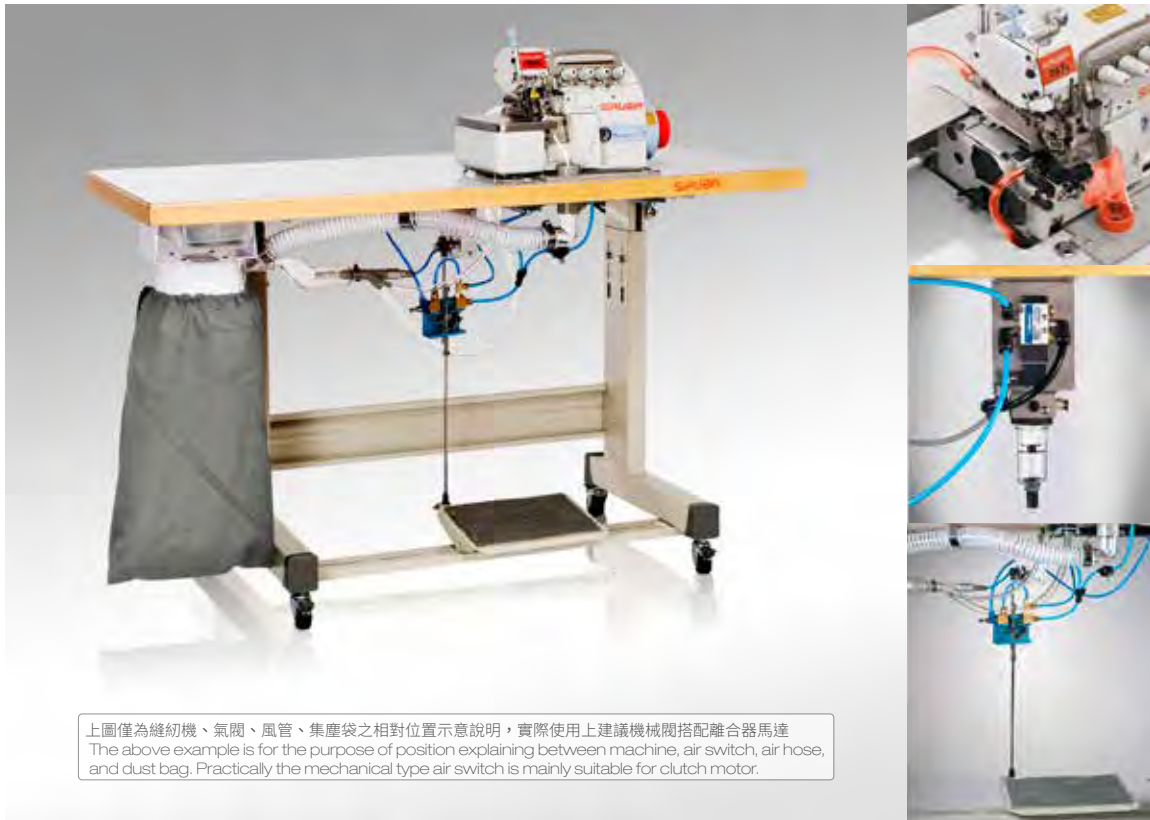

上圖僅為縫紉機、氣閥、風管、集塵袋之相對位置示意說明，實際使用上建議機械閥搭配離合器馬達
The above example is for the purpose of position explaining between machine, air switch, air hose, and dust bag. Practically the mechanical type air switch is mainly suitable for clutch motor.

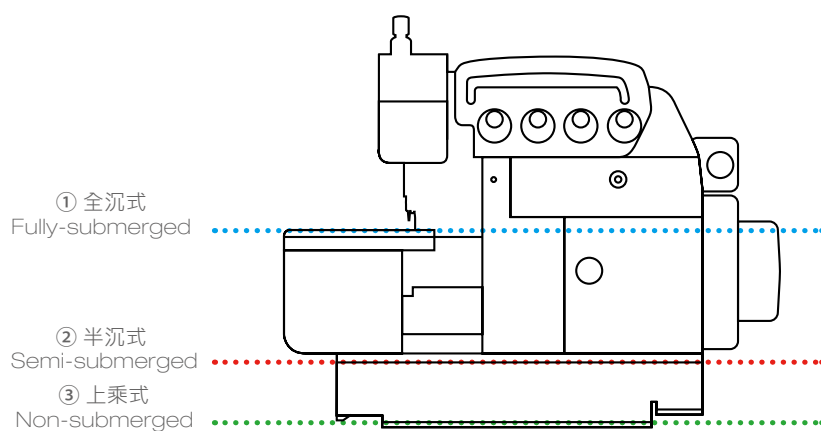

TABLE

桌板代號 Item No.	尺寸 / Size (mm)			說明 Description	適用機型 Applicable Model	備註 Remark
	長 Length	寬 Width	厚 Thickness			
700K-T	1200	540	40	② 半沉式 Semi-submerged	700L, 700LX, 700K, 700KT 一般車 700L, 700LX, 700K, 700KT Standard Model	
700K-T2	1200	540	40	① 全沉式 Fully-submerged	700L, 700LX, 700K, 700KT 一般車 700L, 700LX, 700K, 700KT Standard Model	需搭配 TBK-1 TBK-1 set required
700K-T3	1200	540	40	① 全沉式 Fully-submerged	700K/EC, CT, VT	需搭配 TBK-1 TBK-1 set required
700K-T4	1200	540	40	② 半沉式 Semi-submerged	700L/BKF, 700K/BKF	
700LD-T	1200	540	40	② 半沉式 Semi-submerged	700L, 700LX 直驅車 700L, 700LX DD Motor Model	
700KD-T	1200	540	40	② 半沉式 Semi-submerged	700K 直驅車 700K DD Motor Model	
700KD-T2	1200	540	40	① 全沉式 Fully-submerged	700K 直驅車 700K DD Motor Model	需搭配 TBKD-1 TBKD-1 set required
700KD-T3	1200	540	40	① 全沉式 Fully-submerged	700K/FLP, EC, VT, CT	需搭配 TBK-1 TBK-1 set required
700KS-T	1200	540	40	② 半沉式 Semi-submerged	700KS, 700KST	
700KS-T2	1200	540	40	② 半沉式 Semi-submerged	700KS, 700KST 直驅車 700KS, 700KST DD Motor Model	
700LD-T1	1200	540	40	② 半沉式 Semi-submerged	700LD/UC,SD	
700KS-T1	1200	540	40	② 半沉式 Semi-submerged	700KS, 700KST	開口型 Open type
700KS-T3	1200	540	40	② 半沉式 Semi-submerged	700KS, 700KST 直驅車 700KS, 700KST DD Motor Model	開口型 Open type
700KS-T4	1200	540	40	② 半沉式 Semi-submerged	700KS, 700KST	開口型搭 KX10E-A布漏組 Open type with KX10E-A cloth slide

INTERLOCK STITCH

High speed interlock stitch machine

C007 L - W 12 2 - 3 56 / CQ

系列 Series

L	高速型 Ultra high speed
LX	微油型 Semi-Dry
JP	J型進階款 J plus
K	基本款 Basic type
KD	基本款配直驅馬達 K type with DD motor

功能 Function

12	一般平縫 General plain seaming
13	拷下擺 Bottom hemming
15	羅紋褲頭鬆緊帶包縫 Tubular rib-fabric elastic waistband attaching
16	一般厚布料之平縫 General plain seaming for heavy material
22	滾邊車縫 Tape binding
32	拷克骨車縫 Overlock-seam covering
51	鬆緊帶上帶車縫 Elastic tape attaching
52	鬆緊帶附右切刀 Elastic tape attaching with right side fabric trimmer
53	環型鬆緊帶車縫 Tubular elastic waistband attaching
54	鬆緊帶折縫 Elastic hemming
61	褲耳車縫 Belt loop seaming
71	雙勾針結構 Double-looper mechanism
72	三勾針結構 Triple-looper mechanism
81	左切刀修布裝置 Left side fabric trimming
82	鬆緊帶上帶邊縫附左切刀 Elastic tape insertion with left side fabric trimmer
92	四針六線搭接縫 Four-needle flat seaming

針數

Needle numbers

No.	mm	inch
32	3.2	1/8
40	4.0	5/32
48	4.8	3/16
56	5.6	7/32
64	6.4	1/4

配件

Device

機種別 Model

C	筒型 Cylinder bed
F	平台型 Flat bed
S	小筒型 Small cylinder bed
U	超小筒 Ultra Small cylinder bed

網線方式 Covering types

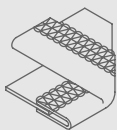
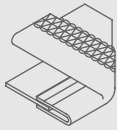
W	
U	

針板舌片

Needle plate finger

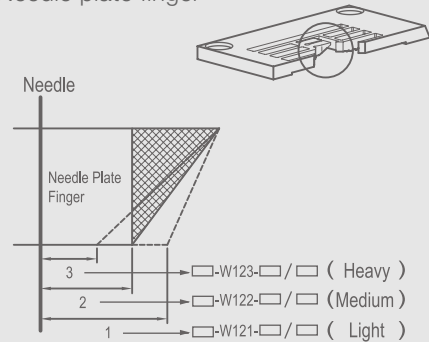

- 1 = 薄布料/細結線(密針)
Light material/Short stitch length
- 2 = 中厚布料/中結線(一般針)
Medium material/Common stitch length
- 3 = 厚布料/粗結線(粗針)
Heavy material/Long stitch length
- 5 = 厚薄通用針板
Heavy to light wide range needle plate

DCL□□ C007L/LX型直驅電控組
Direct-Drive Servo Motor for C007L/LX

DCK□□ C007KD型直驅電控組
Direct-Drive Servo Motor for C007KD

DFK□□ F007KD型直驅電控組
Direct-Drive Servo Motor for F007KD

DSK□□ S007KD, U007, C007JP型直驅電控組
Direct-Drive Servo Motor for S007KD, U007, C007JP

INTERLOCK DD SERVO MOTOR

C007KD-W162-364 / CH / DCK□□

登峰

Ascend to Greatness

造極

C007LX

C007L SERIES

C007L

超高速型繡縫機

Ultra High Speed Cylinder Bed
Interlock Stitch Machine

C007LX

微油超高速型繡縫機

Semi-Dry Ultra High Speed Cylinder
Bed Interlock Stitch Machine

C007L/LX SERIES FEATURES

結合SiRUBA最高端技術的旗艦機種

Flagship model with SiRUBA's state-of-the-art innovation.



內縮式床台

縫製物更靠近針孔，車縫定位精準，車縫時更加順暢就手

The Recessed Machine Bed

With the recessed machine bed, sewing material comes closer to the needle hole, thus provides more precise easier, and smoother sewing.



短筒座的設計

操作性能優越，可因應廣泛的飾蓋縫紉工程，增加延伸蓋就可以車縫邊或包帶之縫紉工程

Recessed Cylinder Bed

The recessed cylinder bed on the front cover is shortened. The short cylinder has superior operating performance, which can be applied to the extensive covering seam. Hemming or wrapping can be sewed just by increasing the extended cover.



針棒與勾針的新油封結構

新的油封設計強化了機構的油附著力，減少了潤滑油甩出。同時使用高耐磨材料，顯著提高性能及替代

New Oil Sealing Technology

New oil sealing structure used on needle bar and looper mechanism can efficiently avoid oil splash. New wear-resistant material also enhances performance and durability.



新型散熱結構同時降低震動

全新散熱設計提供最佳降溫效率。更穩固的防震結構，提升機械的安定與精度，車縫體驗更為順暢

New Cool Down Technology

Frame structure renewed with better cooling mechanism. Vibration is also reduced to contribute better sewing experience.

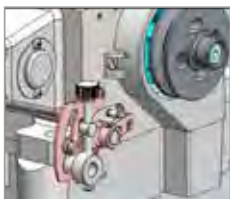

直感式的差動送具調整

差動送具的調整機構設計在縫紉機本體的右後方，於車縫時使用右手直感操作，精準無誤

Easy-to-adjust Differential Feed Dog Design

The differential feed dog adjuster is placed at right side of the operator. Adjust it easily without hesitation.



新設計上夾線裝置
出刀迅速精準·夾線穩定

Brand New Design Upper Thread Gripper

The newly designed upper thread gripper provides fast, precise movement and stable thread gripper.

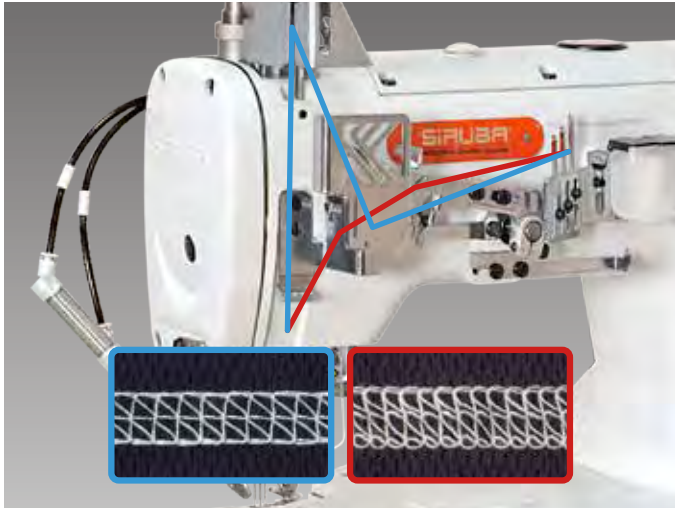

雙天秤挑線控線組

全新雙天秤挑線控線組的設計·縫製厚、薄布料皆適用·車縫適用範圍更廣·適用性更高

Dual Thread Take-up Mechanism

The brand new design of dual thread take-up lever thread tension combination is ideal for both heavy and light fabric. Sewing applicable range is wider and the applicability is higher.

- 中厚布料 (Medium heavy fabric)
- 薄布料 (Light fabric)



C007LX series

無油無慮 Oilless is trouble-free.

SiRUBA 的三針車提供您暢快的縫製體驗

C007LX provides you all new sewing experience.

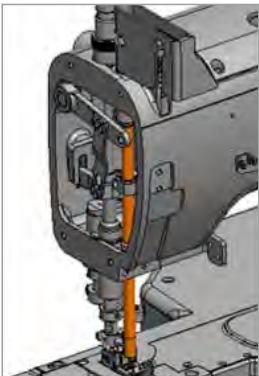

針棒採用特殊的表面處理·縫製時無油污污漬·顯著提高縫製品質·減少重工與縫製品髒污垢·針棒潤滑機構同時再進化·增加零件耐久度

Needle bar mechanism re-designed with new surface treatment, no oil stains and oil splash during operating, greatly increase sewing quality. Needle bar also has better durability due to new lubrication mechanism.

C007L/C007LX										
一般平縫 / 下擺車縫 General Seaming/ Bottom Hemming	C007L-W125-2□□/CH	2	4	3.2/ 4.0/ 4.8	1.4-3.6	0.9~1.4	5/7	UYX128GAS#10	6000	
	C007L-W125-3□□/CH	3	5	4.8/ 5.6/ 6.4	1.4-3.6	0.9~1.4	5/7	UYX128GAS#10	6000	
	C007L-U125-2□□/CH	2	3	3.2/ 4.0/ 4.8	1.4-3.6	0.9~1.4	5/7	UYX128GAS#10	6000	
	C007L-U125-3□□/CH	3	4	4.8/ 5.6/ 6.4	1.4-3.6	0.9~1.4	5/7	UYX128GAS#10	6000	
	C007L-W165-2□□/CH	2	4	4.0/ 4.8	1.4-3.6	0.9~1.4	5/7	UYX128GAS#10	6000	
	C007L-W165-3□□/CH	3	5	4.0/ 4.8	1.4-3.6	0.9~1.4	5/7	UYX128GAS#10	6000	
選購配件 : UTP, UTQ, UTR, UTS, CLA, CMR, CAR/UTP, CAR/UTQ Optional Device: UTP, UTQ, UTR, UTS, CLA, CMR, CAR/UTP, CAR/UTQ										
拷克倒骨蓋縫 Overlock-seam Covering Stitch	C007L-W325-3□□/CC	3	5	5.6/ 6.4	1.4-3.6	0.9~1.4	5/7	UYX128GAS#10	6000	
	C007L-U325-3□□/CC	3	4	5.6/ 6.4	1.4-3.6	0.9~1.4	5/7	UYX128GAS#10	6000	
	C007L-W325-3□□/CE	3	5	5.6/ 6.4	1.4-3.6	0.9~1.4	5/7	UYX128GAS#10	6000	
	C007L-U325-3□□/CE	3	4	5.6/ 6.4	1.4-3.6	0.9~1.4	5/7	UYX128GAS#10	6000	
選購配件 : UTP, UTQ, UTR, UTS, CLA, CMR, CAR/UTP, CAR/UTQ Optional Device: UTP, UTQ, UTR, UTS, CLA, CMR, CAR/UTP, CAR/UTQ										
環型鬆緊帶褲頭接縫 Tubular Jacquard Elastic Waistband Attaching	C007L-W535-232/CR/UTP/CL/RLP/CX	2	4	3.2	1.4-3.6	0.9~1.4	5/7	UYX128GAS#10	5000	
	C007L-W535-3□□/CR/UTP/CL/RLP/CX	3	5	5.6/ 6.4	1.4-3.6	0.9~1.4	5/7	UYX128GAS#10	5000	
	C007L-U535-232/CR/UTP/CL/RLP/CX	2	3	3.2	1.4-3.6	0.9~1.4	5/7	UYX128GAS#10	5000	
	C007L-U535-3□□/CR/UTP/CL/RLP/CX	3	4	5.6/ 6.4	1.4-3.6	0.9~1.4	5/7	UYX128GAS#10	5000	
左切刀修布下擺車縫 Bottom Hemming with Left Side Fabric Trimmer	C007L-W815-2□□/CRL/RL	2	4	4.0/ 4.8	1.4-3.6	0.9~1.4	5/7	UYX128GAS#10	5000	
	C007L-W815-3□□/CRL/RL	3	5	5.6/ 6.4	1.4-3.6	0.9~1.4	5/7	UYX128GAS#10	5000	
	C007L-U815-2□□/CRL/RL	2	3	4.0/ 4.8	1.4-3.6	0.9~1.4	5/7	UYX128GAS#10	5000	
	C007L-U815-3□□/CRL/RL	3	4	5.6/ 6.4	1.4-3.6	0.9~1.4	5/7	UYX128GAS#10	5000	
	C007L-W815A-2□□/CRL/RL	2	4	4.0/ 4.8	1.4-3.6	0.9~1.4	5/7	UYX128GAS#10	5000	
	C007L-W815A-3□□/CRL/RL	3	5	5.6/ 6.4	1.4-3.6	0.9~1.4	5/7	UYX128GAS#10	5000	
	C007L-U815A-2□□/CRL/RL	2	3	4.0/ 4.8	1.4-3.6	0.9~1.4	5/7	UYX128GAS#10	5000	
	C007L-U815A-3□□/CRL/RL	3	4	5.6/ 6.4	1.4-3.6	0.9~1.4	5/7	UYX128GAS#10	5000	
選購配件 : UTP, UTQ, UTR, CMR, CAR/UTP, CAR/UTQ Optional Device: UTP, UTQ, UTR, CMR, CAR/UTP, CAR/UTQ										
鬆緊帶上帶邊縫 附左切刀 Elastic Attaching with Left Fabric Trimmer	C007L-W825-2□□/CRL/CL/RL	2	4	4.0/ 4.8	1.4-3.6	0.9~1.4	5/7	UYX128GAS#10	5000	
	C007L-W825-3□□/CRL/CL/RL	3	5	5.6/ 6.4	1.4-3.6	0.9~1.4	5/7	UYX128GAS#10	5000	
	C007L-U825-2□□/CRL/CL/RL	2	3	4.0/ 4.8	1.4-3.6	0.9~1.4	5/7	UYX128GAS#10	5000	
	C007L-U825-3□□/CRL/CL/RL	3	4	5.6/ 6.4	1.4-3.6	0.9~1.4	5/7	UYX128GAS#10	5000	
	C007L-W825A-2□□/CRL/CL/RL	2	4	4.0/ 4.8	1.4-3.6	0.9~1.4	5/7	UYX128GAS#10	5000	
	C007L-W825A-3□□/CRL/CL/RL	3	5	5.6/ 6.4	1.4-3.6	0.9~1.4	5/7	UYX128GAS#10	5000	
選購配件 : UTP, UTQ, CMR, CAR/UTQ Optional Device: UTP, UTQ, CMR, CAR/UTQ										

CRL用針板類型
Needle Plates for CRL

W8□□ 4排齒 4 rows



W8□□A 5排齒 5 rows



C007K/KD SERIES FEATURES



內縮式床台

縫製物更靠近針孔，車縫定位精準，車縫時更加順暢就手

The Recessed Machine Bed

With the recessed machine bed, sewing material comes closer to the needle hole, thus provides more precise easier, and smoother sewing.



新設計上下切刀組

新設計氣、電動上下切刀組，出刀穩定精確，切線俐落，調整容易

Brand New Top and Under Trimmer

The newly designed pneumatic, electric top & under knife combination have fast, stable and precise. Trims thread neatly. Handy operation, easy to adjust.



針棒與勾針的新油封結構

新的油封設計強化了機構的油附著力，減少了潤滑油甩出。同時使用高耐磨材料，顯著提高性能及替代

New Oil Sealing Technology

New oil sealing structure used on needle bar and looper mechanism can efficiently avoid oil splash. New wear-resistant material also enhances performance and durability.



小型投射LED

小型投射LED照明，穿線或調整機針作業方便（選配）

Small LED Light

Led light, convenient for threading or adjusting the needle. (Optional)



短筒座的設計

操作性能優越，可因應廣泛的飾蓋縫紉工程，增加延伸蓋就可以車縫邊或包帶之縫紉工程

Recessed Cylinder Bed

The recessed cylinder bed on the front cover is shortened. The short cylinder has superior operating performance, which can be applied to the extensive covering seam. Hemming or wrapping can be sewed just by increasing the extended cover.

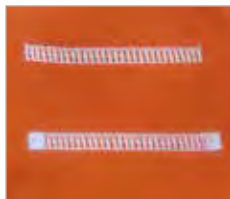

密縫裝置

藉由縮短送具行程，在車縫起始或結束進行密縫的功能，確保縫線不易脫落，提高車縫品質，基本車為腳踏板控制，電動和氣動控制為選配

Condense Stitching Device

By reducing the strokes of feed dog, at the beginning and the end of sewing, condense stitching reinforces the stitches. This enhances the sewing sturdiness and quality. Basic model is controlled by pedal. Electric and pneumatic controls are optional.



新設計上夾線裝置

出刀迅速精準 · 夾線穩定

Brand New Design Upper Thread Gripper

The newly designed upper thread gripper provides fast, precise movement and stable thread gripper.



送具並列式調整鈕設計

[專利] 前送齒及後送齒 · 藉由全新並列式調整鈕設計 · 可獨自調整同步或正逆差動 · 指標刻度方便使用者進行精確調整前後送齒 · 大大提升操作者使用上的便利性

Front and Rear Feed Dog Minute Adjustment

[Patent] Synchronization or forward / reverse differential of front and rear feed dog can be finely adjusted alone by the brand new parallel adjustable feed dog control knobs. Furthermore, the indicator scales is easy for user to adjust the feeding precisely, which improves ease of operation greatly.

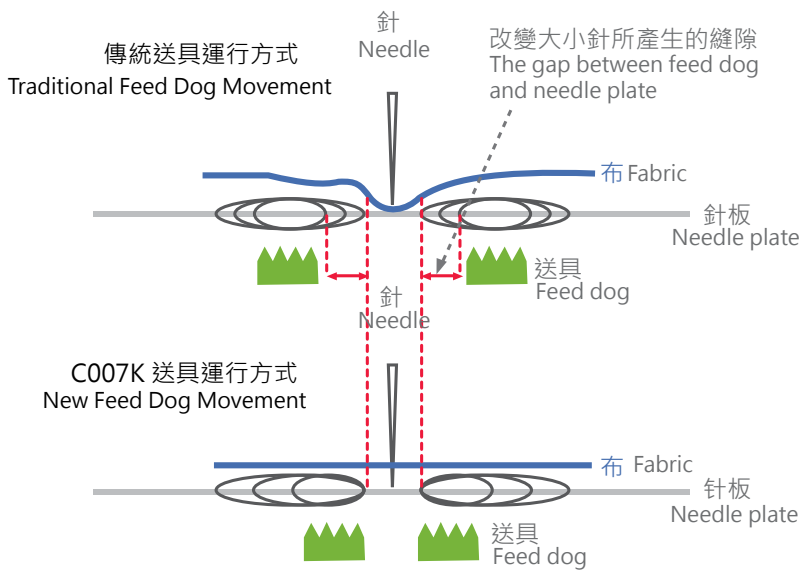

全新移動送齒之傳動設計

[專利] 後、前送齒依據橢圓式運動方式 · 統一由針孔向外運動延伸 · 縫製物可獲得精準穩定送布 · 也不會因為過骨或差動而前、後送具產生間隙 · 影響車縫品質

Brand New Differential Feed Dog Driving Design

[Patent] The front and rear feed dog move elliptically, and centrally, a direct extension from needle hole, thus enable sewing material to get precise and stable feeding. Therefore, the sewing quality will not be affected by the clearance between front and rear feed dog which is resulted from the cross seam or differential action.



雙天秤挑線控線組

全新雙天秤挑線控線組的設計 · 縫製厚、薄布料皆適用 · 車縫適用範圍更廣 · 適用性更高

Dual Thread Take-up Mechanism

The brand new design of dual thread take-up lever thread tension combination is ideal for both heavy and light fabric. Sewing applicable range is wider and the applicability is higher.

- 中厚布料 (Medium heavy fabric)
- 薄布料 (Light fabric)

C1



Model	2	4	3.2/ 4.0/ 4.8	1.4 ~ 3.6	0.3 ~ 2.9	5/7	UYX128GAS#10	6000
C007K-W125-□□□/CH	2	4	3.2/ 4.0/ 4.8	1.4 ~ 3.6	0.3 ~ 2.9	5/7	UYX128GAS#10	6000
	3	5	4.8/ 5.6/ 6.4	1.4 ~ 3.6	0.3 ~ 2.9	5/7	UYX128GAS#10	6000
C007K-W162-□□□/CH	2	4	4.0/ 4.8	1.4 ~ 3.6	0.3 ~ 2.9	5/7	TVX5#14~#16	6000
	3	5	4.8/ 5.6/ 6.4	1.4 ~ 3.6	0.3 ~ 2.9	5/7	TVX5#14~#16	6000
C007K-W125-□□□/CH-3M	3	5	5.6/ 6.4	1.4 ~ 3.6	0.3 ~ 2.9	5/7	UYX128GAS#10	6000
C007KD-W125-□□□/CH/DC□	2	4	3.2/ 4.0/ 4.8	1.4 ~ 3.6	0.3 ~ 2.9	5/7	UYX128GAS#10	6000
	3	5	4.8/ 5.6/ 6.4	1.4 ~ 3.6	0.3 ~ 2.9	5/7	UYX128GAS#10	6000
C007KD-W162-□□□/CH/DC□	2	4	4.0/ 4.8	1.4 ~ 3.6	0.3 ~ 2.9	5/7	TVX5#14~#16	6000
	3	5	4.8/ 5.6/ 6.4	1.4 ~ 3.6	0.3 ~ 2.9	5/7	TVX5#14~#16	6000
C007KD-W125-□□□/CH-3M/DC□	3	5	5.6/ 6.4	1.4 ~ 3.6	0.3 ~ 2.9	5/7	UYX128GAS#10	6000



C007K-W125-356/CH/UTP

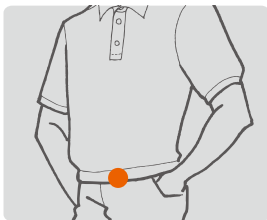

一般平縫 / 下擺車

本機型為雙面飾繃縫筒車之基本機型，可裝配附件進行多種功能車縫
例如：內衣褲、運動衫接縫及下擺車縫(附可調式下擺車縫組)

GENERAL SEAMING / BOTTOM HEMMING

Basic model of interlock stitch machine with double side cover-stitching. It is available for various sewing by optional devices. Such as plain seaming and bottom hemming for underwears, sportswears, etc... (equipped with adjustable hemming set)

W125 : 薄中厚多功能對應針板

W162 : 高行程

W125 : Light / Medium / Heavy Material Multi-function

W162 : High needle bar stroke

選購配件 OPTIONAL DEVICE

UTP, UTQ, UTR, UTS, CLA, CMR, CAR/UTP, CAR/UTQ

C2

			mm				mm	Needle No.	S.P.M. (Max)
C007K-W815(A)-□□□/ CRL	2	4	3.2/ 4.0/ 4.8	1.4 ~ 3.6	0.3 ~ 2.9	5/7	UYX128GAS#10	4500	
	3	5	5.6/ 6.4	1.4 ~ 3.6	0.3 ~ 2.9	5	UYX128GAS#10	4500	
C007KD-W815(A)-□□□/ CRL/DC□	2	4	3.2/ 4.0/ 4.8	1.4 ~ 3.6	0.3 ~ 2.9	5/7	UYX128GAS#10	4500	
	3	5	5.6/ 6.4	1.4 ~ 3.6	0.3 ~ 2.9	5	UYX128GAS#10	4500	



C007K-W815-356/
CRL

適用規格 APPLICABLE SPEC.
W815, U815

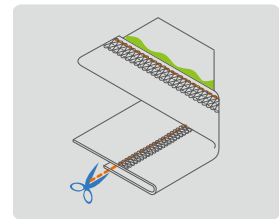
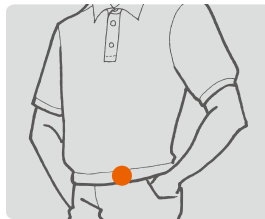

左切刀修布下擺車縫

附左切刀修齊布邊後，再進行下擺車縫工程，適用於車縫T恤、汗衫之下擺等

BOTTOM HEMMING WITH LEFT SIDE FABRIC TRIMMER

Left hand side fabric trimming before hemming. For sleeve opening and bottom of underwears, T-shirt, or sportswears, etc...

W8□□

W8□□A

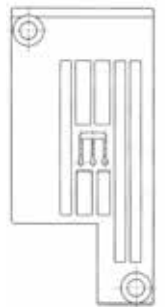
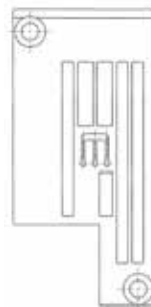

選購配件 OPTIONAL DEVICE
UTP, UTQ, UTR, CL, CMR, CAR/UTP, CAR/UTQ

C3

			mm				mm	Needle No.	S.P.M. (Max)
C007K-U131-256/CHK/UTQ	2	3	5.6	1.4 ~ 3.6	0.3 ~ 2.9	5	UYX128GAS	6000	
C007KD-U131-256/CHK/UTQ/DC□	2	3	5.6	1.4 ~ 3.6	0.3 ~ 2.9	5	UYX128GAS	6000	



C007K-U131-256/
CHK/UTQ



半自動下擺車縫

T恤、內衣及兒童服飾之下擺及袖口之車縫，可隨需要調整下擺飾縫組寬度，操作簡單快捷

CHK-A1 用於一般機型

CHK-UT 用於自動切線機型

SEMI-AUTO HEMMING

Suitable for bottom hemming of T-shirt, underwears, cuff of children's garments, etc... Able to adjust the width of hemming set to fit demands, easy operation.

CHK-A1 is for normal type machine

CHK-UT is for auto trimmer type machine

C4

								
C007K-W222-□□□/□CQ	2	4	4.0/ 4.8	1.4 ~ 3.6	0.3 ~ 2.9	5/7	UYX128GAS#10	6000
	3	5	5.6/ 6.4	1.4 ~ 3.6	0.3 ~ 2.9	5/7	UYX128GAS#10	6000
C007KD-W222-□□□/□CQ/□DC□	2	4	4.0/ 4.8	1.4 ~ 3.6	0.3 ~ 2.9	5/7	UYX128GAS#10	6000
	3	5	5.6/ 6.4	1.4 ~ 3.6	0.3 ~ 2.9	5/7	UYX128GAS#10	6000
C007K-W222-□□□/□CQA	3	5	5.6	1.4 ~ 3.6	0.3 ~ 2.9	5	TVX5#14	5000
C007KD-W222-□□□/□CQA/□DC□	3	5	5.6	1.4 ~ 3.6	0.3 ~ 2.9	5	TVX5#14	5000



C007K-W222-356/CQ



C007K-W222-356/CQA

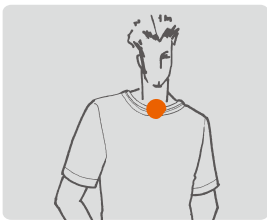

CQ

CQ:上帶滾邊車縫

適用於內衣褲、T恤之領口、褲管口等上帶滾邊之車縫工程

註：滾邊器尺寸為入布端寬1-3/8"，出布時折成三折，出口端成品寬為1/2"

CQ:TAPE BINDING

For tape binding on openings of leg or neck of underwears, T-shirts, etc...

Remark : Binder's opening size is 1-3/8" wide and finished size is 1/2" wide in three folds.



CQA:中厚毯上帶滾邊車縫

適用於中厚毯上帶滾邊之車縫工程

註：滾邊器尺寸為入布端寬72mm，出布時折成二折，出口端成品寬為36mm

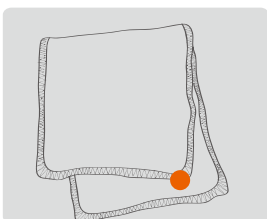

CQA

CQA:BLANKET CARPET TAPE BINDING

For medium and heavy material tape binding.

Remark : Binder's opening size is 72mm wide and finished size is 36mm wide in two folds.

選購配件 OPTIONAL DEVICE

CLA, FA

C5



C007K-W322-3□□/CC	3	5	5.6/ 6.4	1.4 ~ 3.6	0.3 ~ 2.9	5	UYX128GAS#10	6000
C007K-W322A-3□□/CC	3	5	5.6/ 6.4	1.4 ~ 3.6	0.3 ~ 2.9	5	UYX128GAS#10	6000
C007K-W322-3□□/CE	3	5	5.6/ 6.4	1.4 ~ 3.6	0.3 ~ 2.9	5	UYX128GAS#10	6000
C007KD-W322-3□□/CC/DC□	3	5	5.6/ 6.4	1.4 ~ 3.6	0.3 ~ 2.9	5	UYX128GAS#10	6000
C007KD-W322A-3□□/CC/DC□	3	5	5.6/ 6.4	1.4 ~ 3.6	0.3 ~ 2.9	5	UYX128GAS#10	6000
C007KD-W322-3□□/CE/DC□	3	5	5.6/ 6.4	1.4 ~ 3.6	0.3 ~ 2.9	5	UYX128GAS#10	6000



C007K-W322-356/CC



C007K-W322A-356/CC



C007K-W322-356/CE

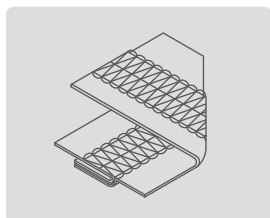

CC

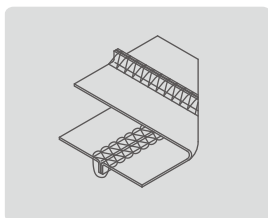

CE



CC

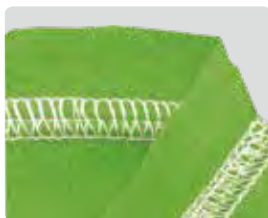

CE

拷克倒骨蓋縫

CC 倒骨型：適用於4線包縫之蓋縫

W322A為兩用型，針板與送具改用W122規格，並附CH組

CE 立骨型：適用於3線包縫之蓋縫

配件盒另附有CC倒骨規格之牛角（導布片）

OVERLOCK-SEAM COVERING STITCH

CC Fold-down type：For 4-thread overlock-seam covering stitch

W322A is dual-purpose specification, which is with W122's needle plate, feed dog and CH set.

CE Flattening type：For 3-thread overlock-seam covering stitch, and an extra guide of overlock-seam (CC specification, fold-down type) is included in the accessory box.

選購配件 OPTIONAL DEVICE

UTP, UTQ, UTR, UTS, CLA, CMR, CAR/UTP, CAR/UTQ

C6

C007K(D)-W515-□□□/FE/(DC□)	2	4	4.0/ 4.8	1.4 ~ 3.6	0.3 ~ 2.9	5	UYX128GAS#10	4500	
	3	5	5.6/ 6.4	1.4 ~ 3.6	0.3 ~ 2.9	5	UYX128GAS#10	4500	
C007K-W515-□□□/FFC	2	4	4.0/ 4.8	1.4 ~ 3.6	0.3 ~ 2.9	5	UYX128GAS#10	4500	
	3	5	5.6/ 6.4	1.4 ~ 3.6	0.3 ~ 2.9	5	UYX128GAS#10	4500	
C007K-W515-□□□/SMK	2	4	4.0/ 4.8	1.4 ~ 3.6	0.3 ~ 2.9	5	UYX128GAS#10	4500	
	3	5	5.6/ 6.4	1.4 ~ 3.6	0.3 ~ 2.9	5	UYX128GAS#10	4500	
C007K-W515-□□□/STC	2	4	4.0/ 4.8	1.4 ~ 3.6	0.3 ~ 2.9	5	UYX128GAS#10	4500	
	3	5	5.6/ 6.4	1.4 ~ 3.6	0.3 ~ 2.9	5	UYX128GAS#10	4500	



C007K-W515-356/FE



C007K-W515-356/FFC

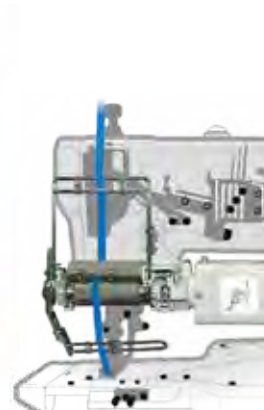

SMK



STC

鬆緊帶 / 蕾絲鬆緊帶上帶車

經由上送帶裝置，控制長度與張力，提高車縫品質，如女用內衣褲之鬆緊帶或蕾絲鬆緊帶車縫

FFC: 機械式送帶

FE: 簡易電子式送帶

SMK: 電子計數式送帶

SMK1-C-01 附定位器，適合簡易伺服或離合器馬達

SMK1-C-02 以中繼線，連接伺服馬達

STC: 張力控制式送帶

STC1-U-01 附定位器，適合簡易伺服或離合器馬達

STC1-U-02 以中繼線，連接伺服馬達

ELASTIC / LACE ATTACHING

Top feeding devices ensure even length and tension controlled by electric digital controller, for elastic or lace attaching smoothly and properly on women's underwears.

FFC: Mechanic type tape feeding.

FE: Simple electric type tape feeding.

SMK: Electric metering type tape feeding

SMK1-C-01 with synchronizer for simple servo motor or clutch motor

SMK1-C-02 Connected to servo motor by encoder cable.

STC: Tension sensor type tape feeding

STC1-U-01 with synchronizer for simple servo motor or clutch motor

STC1-U-02 Connected to servo motor by encoder cable.

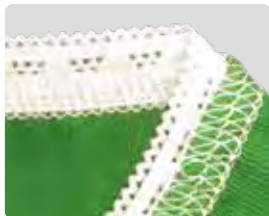
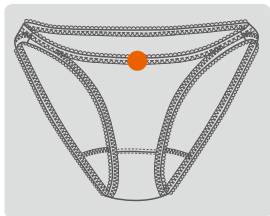

選購配件 OPTIONAL DEVICE

CL, LF-A, LS-A

C7



Model	2	4	3.2/ 4.0/ 4.8	1.4 ~ 3.6	0.3 ~ 2.9	5	UYX128GAS#11	4500
C007K-W525-□□□/CR/FE	2	4	3.2/ 4.0/ 4.8	1.4 ~ 3.6	0.3 ~ 2.9	5	UYX128GAS#11	4500
	3	5	4.8/ 5.6/ 6.4	1.4 ~ 3.6	0.3 ~ 2.9	5	UYX128GAS#11	4500
C007K-W525-□□□/CR/FFC	2	4	3.2/ 4.0/ 4.8	1.4 ~ 3.6	0.3 ~ 2.9	5	UYX128GAS#11	4500
	3	5	4.8/ 5.6/ 6.4	1.4 ~ 3.6	0.3 ~ 2.9	5	UYX128GAS#11	4500
C007K-W525-□□□/CR/SMK	2	4	3.2/ 4.0/ 4.8	1.4 ~ 3.6	0.3 ~ 2.9	5	UYX128GAS#11	4500
	3	5	4.8/ 5.6/ 6.4	1.4 ~ 3.6	0.3 ~ 2.9	5	UYX128GAS#11	4500
C007K-W525-□□□/CR/STC	2	4	3.2/ 4.0/ 4.8	1.4 ~ 3.6	0.3 ~ 2.9	5	UYX128GAS#11	4500
	3	5	4.8/ 5.6/ 6.4	1.4 ~ 3.6	0.3 ~ 2.9	5	UYX128GAS#11	4500



C007K-W525-356/CR/FE



C007K-W525-356/CR/FFC



SMK



STC

鬆緊帶 / 蕾絲鬆緊帶上帶車縫附右切刀

經由上送帶裝置，控制長度與張力，附右切刀修布裝置，能於車縫前將布修齊，更能提高車縫品質，如女用內衣褲之鬆緊帶或蕾絲鬆緊帶車縫

FFC: 機械式送帶

FE: 簡易電子式送帶

SMK: 電子計數式送帶

SMK1-C-01 附定位器，適合簡易伺服或離合器馬達

SMK1-C-02 以中繼線，連接伺服馬達

STC: 张力控制式送帶

STC1-U-01 附定位器，適合簡易伺服或離合器馬達

STC1-U-02 以中繼線，連接伺服馬達

ELASTIC / LACE ATTACHING WITH RIGHT FABRIC TRIMMER

Top feeding devices ensure even length and tension controlled by electric digital controller, with right side fabric trimmer for elastic or lace attaching smoothly and properly on women's underwears.

FFC: Mechanic type tape feeding.

FE: Simple electric type tape feeding.

SMK: Electric metering type tape feeding

SMK1-C-01 with synchronizer for simple servo motor or clutch motor

SMK1-C-02 Connected to servo motor by encoder cable.

STC: Tension sensor type tape feeding

STC1-U-01 with synchronizer for simple servo motor or clutch motor

STC1-U-02 Connected to servo motor by encoder cable.

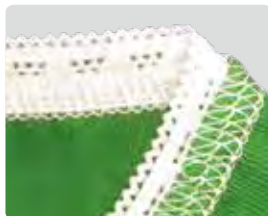
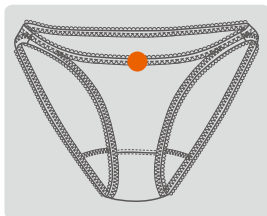
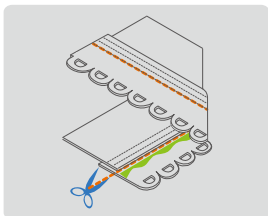

選購配件 OPTIONAL DEVICE

CL, LF-A, LS-A, CSA, CSB

C007K(D)-W535-□□□/CR/CX/UTP/RLP/(DC□) *1	2	4	3.2/ 4.0/ 4.8	1.4 ~ 3.6	0.3 ~ 2.9	5	UYX128GAS#11	4500
	3	5	4.8/ 5.6/ 6.4	1.4 ~ 3.6	0.3 ~ 2.9	5	UYX128GAS#11	4500
C007K(D)-W535-□□□/CR/CX/UTR/RLP/(DC□) *2	2	4	3.2/ 4.0/ 4.8	1.4 ~ 3.6	0.3 ~ 2.9	5	UYX128GAS#11	4500
	3	5	4.8/ 5.6/ 6.4	1.4 ~ 3.6	0.3 ~ 2.9	5	UYX128GAS#11	4500



C007K-W535-356/CR/CX/CL/UTP

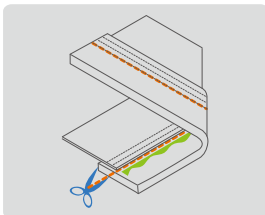
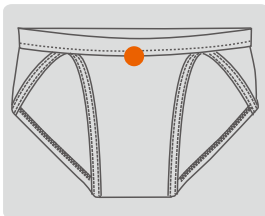

環型鬆緊帶褲頭接縫附右切刀修布邊

將環型平織鬆緊帶與衣物接縫適用於男女內褲褲腰之鬆緊帶縫合，配合右切刀修布裝置，更能提高縫製品質

- *1: 氣動切線，含氣動式吸布屑組
- *2: 電動切線，需另外搭配吸風馬達 (CSA或CSB)

TUBULAR JACQUARD ELASTIC WAISTBAND ATTACHING WITH RIGHT SIDE FABRIC TRIMMER

For tubular elastic or lace waistband attaching on men's or women's brief, with right hand side fabric trimmer to increase sewing quality and efficiency.

- *1: Pneumatic thread trimmer, including fabric waste suction set
- *2: Electric thread trimmer, an optional suction motor (CSA or CSB) is required.

RLP



選購配件 OPTIONAL DEVICE
CL* , CAR/UTQ , CMR , CSA , CSB

- *建議採用CL後拉輪，以提升鬆緊帶車縫效率
- *CL rear puller is recommended for elastic band attaching



C007K-W825-□□□/CRL/CHP(CY)/UTP	2	4	3.2/ 4.0/ 4.8	1.4 ~ 3.6	0.3 ~ 2.9	5	UYX128GAS#10	4500
	3	5	5.6/ 6.4	1.4 ~ 3.6	0.3 ~ 2.9	5	UYX128GAS#10	4500
C007KD-W825-□□□/CRL/CHP(CY)/UTP/DC□	2	4	3.2/ 4.0/ 4.8	1.4 ~ 3.6	0.3 ~ 2.9	5	UYX128GAS#10	4500
	3	5	5.6/ 6.4	1.4 ~ 3.6	0.3 ~ 2.9	5	UYX128GAS#10	4500



C007K-W825-356/CRL/CL/CHP/UTP

[二合一]氣動式下擺車縫 / 環型鬆緊帶折縫 附左切刀修布邊功能

氣動式布料導邊器能將布料及鬆緊帶順暢的捲折，此外左切刀切齊後再進行縫紉，可增加包縫工程之品質與效率，適用於男內褲、運動褲等褲頭鬆緊帶包縫

[2 IN 1] PNEUMATIC HEMMING / TUBULAR ELASTIC TAPE HEMMING WITH LEFT EDGE TRIMMER

With pneumatic driving folder to fold fabric and insert elastic smoothly, left hand side fabric trimming before hemming increases sewing quality & efficiency. For hemming sleeve opening and bottom of underwears, T-shirts, or sportswears, etc...

CHP
氣動式下擺車縫

CY
氣動式環型鬆緊帶折縫

→ Elastic Tape



CHP (CRL 163)
氣動式下擺車縫
Pneumatic Hemming



CY (CRL178-A)
氣動式環型鬆緊帶折縫
Pneumatic Tubular Elastic Tape Hemming

適用規格 APPLICABLE SPEC
W825, U825
選購配件 OPTIONAL DEVICE
CL*, RL, UTQ, CMR, CAR/UTQ

*建議採用CL後拉輪，以提升鬆緊帶車縫效率
*CL rear puller is recommended for elastic band attaching

C10

	3	5	5.6	1.4 ~ 3.6	0.3 ~ 2.9	5	UYX128GAS#10	6000
C007K-W152-356/CZ/RLQ	3	5	5.6	1.4 ~ 3.6	0.3 ~ 2.9	5	UYX128GAS#10	6000
C007K-W152-364/CZ/RLQ	3	5	6.4	1.4 ~ 3.6	0.3 ~ 2.9	5	UYX128GAS#10	6000
C007K-W152-356/CZP/RLQ	3	5	5.6	1.4 ~ 3.6	0.3 ~ 2.9	5	UYX128GAS#10	6000
C007K-W152-364/CZP/RLQ	3	5	6.4	1.4 ~ 3.6	0.3 ~ 2.9	5	UYX128GAS#10	6000
C007KD-W152-356/CZ/RLQ/DC□	3	5	5.6	1.4 ~ 3.6	0.3 ~ 2.9	5	UYX128GAS#10	6000
C007KD-W152-364/CZ/RLQ/DC□	3	5	6.4	1.4 ~ 3.6	0.3 ~ 2.9	5	UYX128GAS#10	6000
C007KD-W152-356/CZP/RLQ/DC□	3	5	5.6	1.4 ~ 3.6	0.3 ~ 2.9	5	UYX128GAS#10	6000
C007KD-W152-364/CZP/RLQ/DC□	3	5	6.4	1.4 ~ 3.6	0.3 ~ 2.9	5	UYX128GAS#10	6000



C007K-W152-356/CZ/UTP

環型羅紋褲頭鬆緊帶包縫

CZ:氣動式 / CZP:膝動式

將環型羅紋鬆緊帶縫入原體，適用於男女內褲、褲腰之羅紋鬆緊帶包縫再配合自動切線裝置及筒型衣物撐開滾輪組，更能提高縫製效率
註：本機型標準配備二折式導布片，可另訂三折式導布片

TUBULAR ELASTIC WAISTBAND ATTACHING

CZ:PNEUMATIC TYPE / CZP: MANUAL TYPE

Attaching tubular elastic tape onto waistband, suitable for briefs. With auto-trimming and tubular extending roller can increase sewing quality and efficiency.

Remark : Two fold fabric guide is standard, three fold fabric guide is optional.

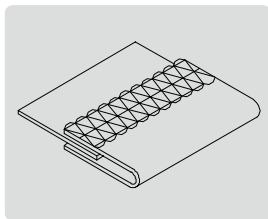
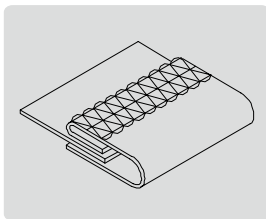
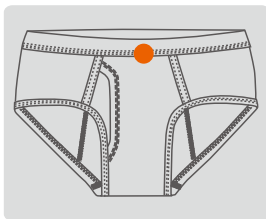

三折 3-Fold
(CZ01K,CZ03K)

兩折 2-Fold
(CZ21K,CZ22K)

RLQ



機型 MODEL	選購配件 OPTIONAL DEVICE
CZ	CL*, UTP, UTQ, CMR, CAR/UTP, CAR/UTQ
CZP	CL*, UTP, UTQ, UTR, UTS, CMR, CAR/UTP, CAR/UTQ

*建議採用CL後拉輪，以提升鬆緊帶車縫效率

*CL rear puller is recommended for elastic band attaching

C11



C007K-W542-□□□/CF	2	4	4.0/ 4.8	1.4 ~ 3.6	0.3 ~ 2.9	5/7	UYX128GAS#11	6000
	3	5	5.6/ 6.4	1.4 ~ 3.6	0.3 ~ 2.9	5/7	UYX128GAS#11	6000
C007K-W542-□□□/SMK	2	4	4.0/ 4.8	1.4 ~ 3.6	0.3 ~ 2.9	5/7	UYX128GAS#11	6000
	3	5	5.6/ 6.4	1.4 ~ 3.6	0.3 ~ 2.9	5/7	UYX128GAS#11	6000
C007K-W542-□□□/STC	2	4	4.0/ 4.8	1.4 ~ 3.6	0.3 ~ 2.9	5/7	UYX128GAS#11	6000
	3	5	5.6/ 6.4	1.4 ~ 3.6	0.3 ~ 2.9	5/7	UYX128GAS#11	6000



C007K-W542-356/CF/CL

鬆緊帶折縫

由下送帶配件，能有效控制鬆緊帶之鬆緊度，配合三折或二折折布喇叭及鬆緊帶壓縫，可精確完美的進行短褲、內褲等褲腳及褲頭之鬆緊帶折縫

CFC: 機械式送帶

SMK: 電子計數式送帶

SMK1-D-01 附定位器，適合簡易伺服或離合器馬達

SMK1-D-02 以中繼線，連接伺服馬達

STC: 張力控制式送帶

STC1-B-01 附定位器，適合簡易伺服或離合器馬達

STC1-B-02 以中繼線，連接伺服馬達

ELASTIC HEMMING

Elastic hemming evenly length and elasticity is controlled by tape feeding device. Great for seam covering with two or three plies hemming binder on elastic for waistband or leg opening of briefs and shorts, etc...

CFC: Mechanic type tape feeding

SMK: Electric metering type tape feeding

SMK1-D-01 with synchronizer for simple servo motor or clutch motor

SMK1-D-02 Connected to servo motor by encoder cable

STC: sensor type tape feeding

STC1-B-01 with synchronizer for simple servo motor or clutch motor

STC1-B-02 Connected to servo motor by encoder cable

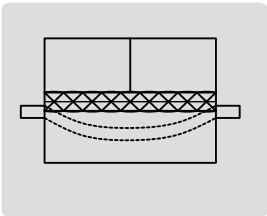
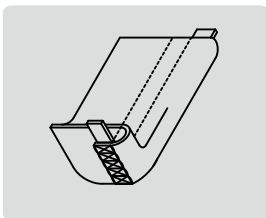
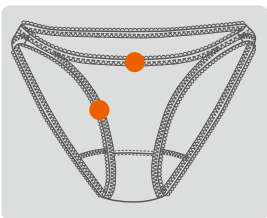

SMK



STC

可選擇之折布喇叭 Optional Binder			
喇叭型式 Binder Type	機型 Model	喇叭代號 Binder No.	成品尺寸 Finished Size
	2	B523	9mm
	2A	B523A	12mm
	3	B524	9mm
	3A	B524A	12mm

選購配件 OPTIONAL DEVICE
FH, CL*

*建議採用CL後拉輪，以提升鬆緊帶車縫效率

*CL rear puller is recommended for elastic band attaching

C12

								
C007K-W925-456/CW	4	6	5.6	1.4 ~ 3.6	0.3 ~ 2.9	5	SMX1014B#10	6000
C007K-W925-460/CW	4	6	6.0	1.4 ~ 3.6	0.3 ~ 2.9	5	SMX1014B#10	6000
C007K-W925-464/CW	4	6	6.4	1.4 ~ 3.6	0.3 ~ 2.9	5	SMX1014B#10	6000
C007KD-W925-456/CW/DC□	4	6	5.6	1.4 ~ 3.6	0.3 ~ 2.9	5	SMX1014B#10	6000
C007KD-W925-460/CW/DC□	4	6	6.0	1.4 ~ 3.6	0.3 ~ 2.9	5	SMX1014B#10	6000
C007KD-W925-464/CW/DC□	4	6	6.4	1.4 ~ 3.6	0.3 ~ 2.9	5	SMX1014B#10	6000



C007K-W925-456/CW

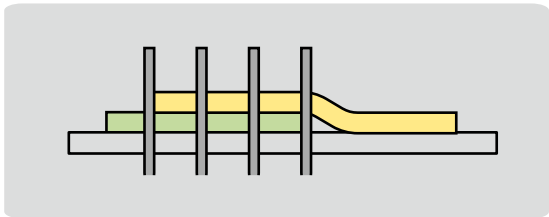
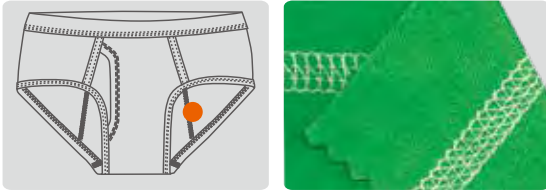

四針六線搭接縫

適用於一般內衣褲二片布接縫處之接縫和補強，附有專屬之導邊器，可使二片布順暢縫合

FOUR-NEEDLE FLAT SEAMING

For flat seaming 2 pieces of fabric. Equipped with fabric guide for easy operation.

CW



選購配件 OPTIONAL DEVICE

UTQ, UTS, CL, CMR, CAR/UTQ

C13



C007KD-W125-□□□/FFT/CH/DC□	2	4	4.0/4.8	1.4 ~ 3.6	0.3 ~ 2.9	1~5.5	5	UYX128GAS#10	4500
	3	5	5.6/6.4	1.4 ~ 3.6	0.3 ~ 2.9	1~5.5	5	UYX128GAS#10	4500
C007KD-W131-□□□/FFT/CH/DC□	2	4	4.0/4.8	1.4 ~ 3.6	0.3 ~ 2.9	1~5.5	5	UYX128GAS#10	4500
	3	5	5.6/6.4	1.4 ~ 3.6	0.3 ~ 2.9	1~5.5	5	UYX128GAS#10	4500
C007KD-W132-□□□/FFT/CH/DC□	2	4	4.0/4.8	1.4 ~ 3.6	0.3 ~ 2.9	1~5.5	5	UYX128GAS#10	4500
	3	5	5.6/6.4	1.4 ~ 3.6	0.3 ~ 2.9	1~5.5	5	UYX128GAS#10	4500
C007KD-W815A-□□□/FFT/CRL/DC□	2	4	4.0/4.8	1.4 ~ 3.6	0.3 ~ 2.9	1~5.5	5	UYX128GAS#10	4500
	3	5	5.6/6.4	1.4 ~ 3.6	0.3 ~ 2.9	1~5.5	5	UYX128GAS#10	4500
C007KD-U815A-□□□/FFT/CRL/DC□	2	4	4.0/4.8	1.4 ~ 3.6	0.3 ~ 2.9	1~5.5	5	UYX128GAS#10	4500
	3	5	5.6/6.4	1.4 ~ 3.6	0.3 ~ 2.9	1~5.5	5	UYX128GAS#10	4500
C007KD-W812A-□□□/FFT/CRL/CW/DC□	4	6	5.6/6.0/6.4	1.4 ~ 3.6	0.3 ~ 2.9	1~5.5	5	UYX128GAS#10	4500



FFT 上送布功能

專利優化前後移動送具之結構設計，有效送布行程大，車縫送布更穩定

FFT TOP FEEDING FUNCTION

Back and forth moving feed dog is designed by patent and improved mechanism. The effective feeding stroke is bigger, and fabric feeding is more stable.

選購配件 OPTIONAL DEVICE

UTP, UTR

CRL用針板類型 Needle Plates for CRL

W8□□

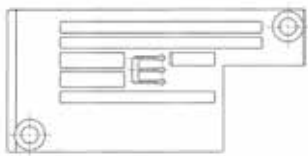

4排齒 4 rows

W8□□A

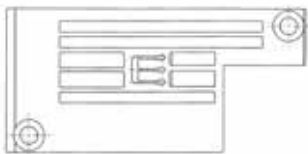

5排齒 5 rows

X Brand

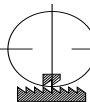

Y Brand

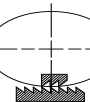

SiRUBA

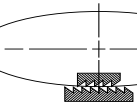
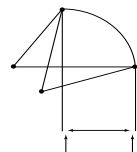

U007 SERIES FEATURES



U007 直驅超小筒型繡縫機 Ultra Small cylinder bed Interlock Stitch Machine



128mm角逐業界最細的小筒設計，過往縫製困難的童裝袖口也可輕易車縫

128mm top-class small cylinder bed design. Conventionally difficult-to-sew small diameter tubular parts of children's clothing can be easily operated.

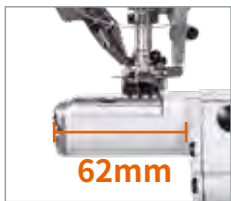

斜面筒嘴設計，縫製衣物著脫容易；筒身長62mm，方便長袖衣物套入車縫

Sharp entrance design allows quick placement/removal of material. 62mm cylinder length makes sewing long sleeve cuffs easily.



圓形粗細針縫目調整鈕的設計，隨心所欲精確調整縫目長短

Circular stitch length adjustment button, easily to adjust stitch length.



自動切線系列新設計氣/電動上下切刀組，出刀迅速穩定精準，切線俐落，輕順低噪音調整容易

Auto trimmer with newly designed pneumatic / electric trimming system, trims precisely and stably, reduce sound and easy to adjust.

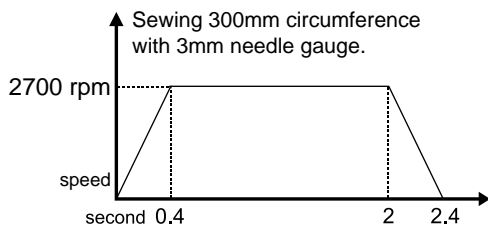

300mm圓周長不需3秒即可完工，2700rpm是對應小筒車縫的完美速度

Just take less than 3 seconds to complete 300mm circumference sewing; 2700rpm is the perfect speed for ultra small cylinder.

規格

SPECIFICATIONS

U007						
				mm	Needle No.	S.P.M. (Max)
U007-W125-2□□/UTT(UTU)	2	4	4.0/4.8	5	UXY128GAS#10	2700
U007-W125-3□□/UTT(UTU)	3	5	5.6/6.4	5	UXY128GAS#10	2700
U007-W125-2□□/UTX(UTY)	2	4	4.0/4.8	5	UXY128GAS#10	2700
U007-W125-3□□/UTX(UTY)	3	5	5.6/6.4	5	UXY128GAS#10	2700

C007JP SERIES FEATURES



應愛好者要求，送具調整回歸過往C007J方式，同時承襲三針車優良進化

C007J comes back due to many customers' request. The feeding mechanism is J type. Also, it is improved with new trimmer and thread take-up lever.

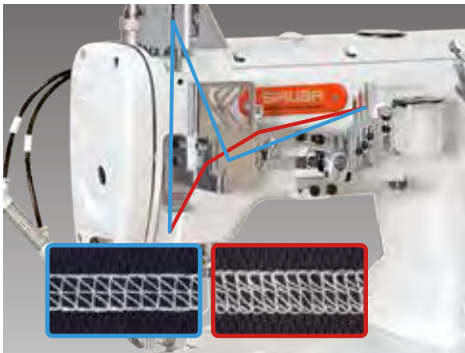

雙天秤挑線控線組

全新雙天秤挑線控線組的設計，縫製厚、薄布料皆適用，車縫適用範圍更廣，適用性更高

Dual Thread Take-up Mechanism

The brand new design of dual thread take-up lever thread tension combination is ideal for both heavy and light fabric. Sewing applicable range is wider and the applicability is higher.

規格

SPECIFICATIONS

C007JP									
					mm	mm	mm	Needle No.	S.P.M. (Max)
一般平縫 / 下擺車縫 General Seaming/ Bottom Hemming	C007JP-W125-2□□/CH	2	4	4.0/ 4.8/ 5.6	1.4-3.6	0.3~2.9	5/7	UYX128GAS#10	6000
	C007JP-W125-3□□/CH	3	5	5.6/ 6.4	1.4-3.6	0.3~2.9	5/7	UYX128GAS#10	6000
左切刀修布下擺車縫 Bottom Hemming with Left Side Fabric	C007JP-W815-2□□/CRL/RL	2	4	4.0/ 4.8	1.4-3.6	0.3~2.9	5/7	UYX128GAS#10	6000
	C007JP-W815-3□□/CRL/RL	3	5	5.6/ 6.4	1.4-3.6	0.3~2.9	5/7	UYX128GAS#10	6000
	C007JP-U815-2□□/CRL/RL	2	3	4.0/ 4.8	1.4-3.6	0.3~2.9	5/7	UYX128GAS#10	6000
	C007JP-U815-3□□/CRL/RL	3	4	5.6/ 6.4	1.4-3.6	0.3~2.9	5/7	UYX128GAS#10	6000
	C007JP-W815A-2□□/CRL/RL	2	4	4.0/ 4.8	1.4-3.6	0.3~2.9	5/7	UYX128GAS#10	6000
	C007JP-W815A-3□□/CRL/RL	3	5	5.6/ 6.4	1.4-3.6	0.3~2.9	5/7	UYX128GAS#10	6000
	C007JP-U815A-2□□/CRL/RL	2	3	4.0/ 4.8	1.4-3.6	0.3~2.9	5/7	UYX128GAS#10	6000
	C007JP-U815A-3□□/CRL/RL	3	4	5.6/ 6.4	1.4-3.6	0.3~2.9	5/7	UYX128GAS#10	6000
鬆緊帶上帶邊縫 附左切刀 Elastic Attaching with Left Fabric Trimmer	C007JP-W825-2□□/CRL/CL/RL	2	4	4.0/ 4.8	1.4-3.6	0.3~2.9	5/7	UYX128GAS#10	6000
	C007JP-W825-3□□/CRL/CL/RL	3	5	5.6/ 6.4	1.4-3.6	0.3~2.9	5/7	UYX128GAS#10	6000
	C007JP-U825-2□□/CRL/CL/RL	2	3	4.0/ 4.8	1.4-3.6	0.3~2.9	5/7	UYX128GAS#10	6000
	C007JP-U825-3□□/CRL/CL/RL	3	4	5.6/ 6.4	1.4-3.6	0.3~2.9	5/7	UYX128GAS#10	6000

S007K/KD SERIES FEATURES



自動切線系列新設計上夾線裝置，出刀迅速精準，夾線穩定

Auto trimmer with newly designed upper thread holder, trims precisely and stably.



三合一壓骨，倒骨，折下擺，更換作業組裝方便，多樣化功能，提供生產廠商高效率低成本

3-in-1 model, including bottom hemming/seam covering/overturnd seam covering, provides high efficiency at less cost.



超小筒徑圓周只有180毫米，車縫小孔徑圓筒針織物，更加方便就手

The small cylinder designed with 180 mm, the extremely small circumference makes sewing operation smoother.



外置式底線分線盤，置於機體前方，調整容易，拆裝方便，可輕易清除絞線

Front exposed looper thread take-up mechanism makes cleaning and adjusting more convenient. After fine tuning the looper thread eyelet holder, sewing can be more accurate.



調整式進布誘導器，活動式壓腳，車縫適用性更廣

Adjustable folder, flexible presser foot, able to accomodate wider range of sewing items.



超短筒的設計，筒邊至中針距離只有31毫米，採密封式之側蓋設計，操作方便順暢

Extremely small tubule design, the distance from cylinder edge to middle needle is only 31 mm. Sealed side cover makes operation more convenient.

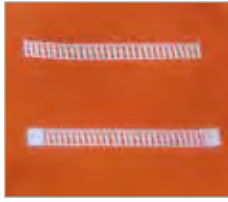

密縫裝置

藉由縮短送具行程，在車縫起始或結束進行密縫的功能，確保縫線不易脫落，提高車縫品質，基本車為腳踏板控制，電動和氣動控制為選配

Condense Stitching Device

By reducing the strokes of feed dog, at the beginning and the end of sewing, condense stitching reinforces the stitches. This enhances the sewing sturdiness and quality. Basic model is controlled by pedal. Electric and pneumatic controls are optional.



自動切線系列新設計氣/電動上下切刀組，出刀迅速穩定精準，切線俐落，輕順低噪音調整容易

Auto trimmer with newly designed pneumatic / electric trimming system, trims precisely and stably, reduce sound and easy to adjust.



全新設計之內藏式定位器，定位精準，徹底解決外置式定位器，不易安裝，調整及定位不穩之情形

Newly designed built-in synchronizer, makes position precisely and stably, easy to adjust.



圓形粗細針縫目調整鈕的設計，隨心所欲精確調整縫目長短

Circular stitch length adjustment button, easily to adjust stitch length.



小型投射LED照明，穿線或調整機針作業方便（選配）

LED light, convenient for threading or adjusting the needle (Optional).

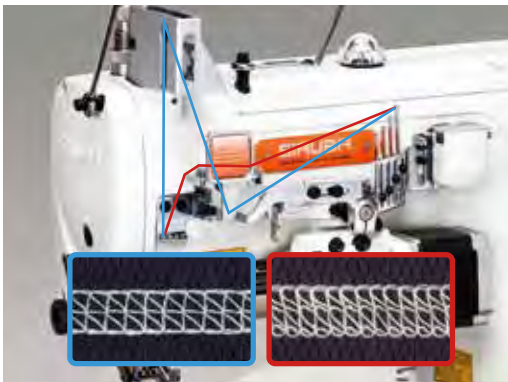

雙天秤挑線控線組

全新雙天秤挑線控線組的設計，縫製厚、薄布料皆適用，車縫適用範圍更廣，適用性更高



Dual Thread Take-up Mechanism

The brand new design of dual thread take-up lever thread tension combination is ideal for both heavy and light fabric. Sewing applicable range is wider and the applicability is higher.

— 中厚布料 (Medium heavy fabric)

— 薄布料 (Light fabric)

S1

								
S007K-W122-240/PCH-3M	2	4	4.0	1.4 ~ 4.2	0.8 ~ 1.4	5/7	UYX128GAS#10	4000
S007K-W122-248/PCH-3M	2	4	4.8	1.4 ~ 4.2	0.8 ~ 1.4	5/7	UYX128GAS#10	4000
S007K-W122-356/PCH-3M	3	5	5.6	1.4 ~ 4.2	0.8 ~ 1.4	5/7	UYX128GAS#10	4000
S007K-W122-364/PCH-3M	3	5	6.4	1.4 ~ 4.2	0.8 ~ 1.4	5/7	UYX128GAS#10	4000
S007KD-W122-240/PCH-3M/DS□	2	4	4.0	1.4 ~ 4.2	0.8 ~ 1.4	5/7	UYX128GAS#10	4000
S007KD-W122-248/PCH-3M/DS□	2	4	4.8	1.4 ~ 4.2	0.8 ~ 1.4	5/7	UYX128GAS#10	4000
S007KD-W122-356/PCH-3M/DS□	3	5	5.6	1.4 ~ 4.2	0.8 ~ 1.4	5/7	UYX128GAS#10	4000
S007KD-W122-364/PCH-3M/DS□	3	5	6.4	1.4 ~ 4.2	0.8 ~ 1.4	5/7	UYX128GAS#10	4000



S007K-W122-356/PCH-3M/UTT

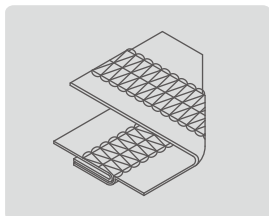

[三合一] 一般平縫 / 下擺車縫 / 拷克倒骨蓋

本機型為雙面飾中厚布用環縫橫式小筒車之基本機型，配附拷克倒骨進行多種功能車縫

例如：內衣褲、運動衫接縫、下擺車縫及倒骨縫

註：可依需求選擇出廠時之校縫

Eg: S007K-W122-356/PCH-3M 以下擺車縫校縫

S007K-W122-356/PCC-3M 以三線拷克倒骨中厚布校縫

S007K-W122-356/PCD-3M 以三線拷克倒骨薄布校縫

[3 IN 1] GENERAL SEAMING / BOTTOM HEMMING / COVERING (Fold-down Type)

This basic model of small cylinder machine. 3-in-1 model, includes bottom hemming/seam covering/overturned seam covering.

Remark : Initial setting can be set according to request :

Eg : S007K-W122-356/PCH-3M Hemming

S007K-W122-356/PCC-3M fold-down seam covering
for medium fabric

S007K-W122-356/PCD-3M fold-down seam covering
for light fabric

選購配件 OPTIONAL DEVICE

UTT , UTU , UTX , UTY , CMR , SAR/UTT , SAR/UTU



Model	2	4	4.0	1.4 ~ 4.2	0.8 ~ 1.4	5/7	UYX128GAS#10	4000
S007K-W322-240/PCE	2	4	4.0	1.4 ~ 4.2	0.8 ~ 1.4	5/7	UYX128GAS#10	4000
S007K-W322-248/PCE	2	4	4.8	1.4 ~ 4.2	0.8 ~ 1.4	5/7	UYX128GAS#10	4000
S007K-W322-356/PCE	3	5	5.6	1.4 ~ 4.2	0.8 ~ 1.4	5/7	UYX128GAS#10	4000
S007K-W322-364/PCE	3	5	6.4	1.4 ~ 4.2	0.8 ~ 1.4	5/7	UYX128GAS#10	4000
S007KD-W322-240/PCE/DS□	2	4	4.0	1.4 ~ 4.2	0.8 ~ 1.4	5/7	UYX128GAS#10	4000
S007KD-W322-248/PCE/DS□	2	4	4.8	1.4 ~ 4.2	0.8 ~ 1.4	5/7	UYX128GAS#10	4000
S007KD-W322-356/PCE/DS□	3	5	5.6	1.4 ~ 4.2	0.8 ~ 1.4	5/7	UYX128GAS#10	4000
S007KD-W322-364/PCE/DS□	3	5	6.4	1.4 ~ 4.2	0.8 ~ 1.4	5/7	UYX128GAS#10	4000



S007K-W322-356/PCE/UTT

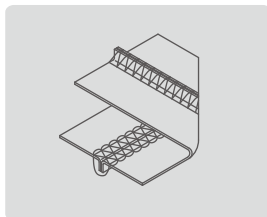
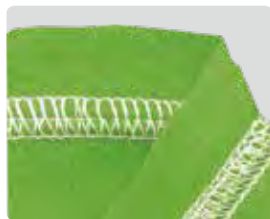

拷克立骨蓋縫

適宜中厚布料，經三線拷克車縫後再包縫，用於運動服、汗衫等領口、下擺、袖管等之拷邊車縫後加以包縫，可增加服飾之美觀及車縫之牢固，利用導布片及壓具上之壓刀導縫，可避免車縫時彎曲不直

OVERLOCK-SEAM COVERING (Flatting Type)

Bulging seam covering for medium fabric after 3 thread plain seaming, suitable for neck openings, sleeve, cuff or bottom of sportswears, T-shirts, etc... With fabric guide and special presser foot, making sewing easy and more efficient.

選購配件 OPTIONAL DEVICE
UTT , UTU , UTX , UTY , SAR/UTT , SAR/UTU , CMR



Model	2	4	4.0/4.8	1.4 ~ 4.2	0.8 ~ 1.4	1~5.5	5	Needle No.	S.P.M. (Max)
S007KD-W121-□□□/FFT/DS□	2	4	4.0/4.8	1.4 ~ 4.2	0.8 ~ 1.4	1~5.5	5	UYX128GAS#10	4000
	3	5	5.6/6.4	1.4 ~ 4.2	0.8 ~ 1.4	1~5.5	5	UYX128GAS#10	4000
S007KD-W122-□□□/FFT/DS□	2	4	4.0/4.8	1.4 ~ 4.2	0.8 ~ 1.4	1~5.5	5	UYX128GAS#10	4000
	3	5	5.6/6.4	1.4 ~ 4.2	0.8 ~ 1.4	1~5.5	5	UYX128GAS#10	4000
S007KD-W131-□□□/FFT/DS□	2	4	4.0/4.8	1.4 ~ 4.2	0.8 ~ 1.4	1~5.5	5	UYX128GAS#10	4000
	3	5	5.6/6.4	1.4 ~ 4.2	0.8 ~ 1.4	1~5.5	5	UYX128GAS#10	4000
S007KD-W132-□□□/FFT/DS□	2	4	4.0/4.8	1.4 ~ 4.2	0.8 ~ 1.4	1~5.5	5	UYX128GAS#10	4000
	3	5	5.6/6.4	1.4 ~ 4.2	0.8 ~ 1.4	1~5.5	5	UYX128GAS#10	4000



FFT 上送布功能

專利優化前後移動送具之結構設計，有效送布行程大，車縫送布更穩定

FFT TOP FEEDING FUNCTION

Back and forth moving feed dog is designed by patent and improved mechanism. The effective feeding stroke is bigger, and fabric feeding is more stable.

選購配件	OPTIONAL DEVICE
UTT, UTX	

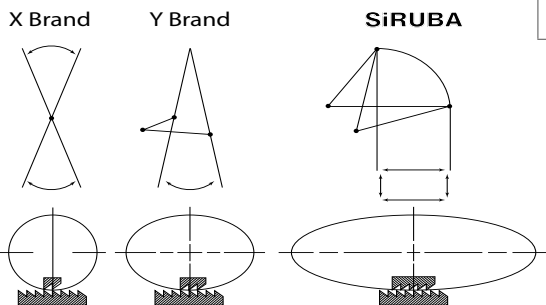

S4



S007KD-U173-100/SAR/RF/UTT/DS□ 1 2 - 1.4 ~ 4.2 0.8 ~ 1.4 5/7 UYX128GAS#18 4000



S007KD-U173-100/SAR/RF/UTT/DS□

單針鏈縫牛仔褲轆腳機

針對彈性牛仔布料的車縫所開發的規格，配備專用的氣動式轆腳喇叭，因為具有差動送布功能，可以車縫出美觀平整的效果

- 標配：氣動式自動切線
 氣動抬壓腳
 直驅伺服馬達
 結束密縫

SINGLE NEEDLE CHAINSTITCH JEANS BOTTOM HEMMING MACHINE

Special gauge for elastic denim fabric, and equipped with pneumatic hemming folder. Because of the function of differential feeding, the sewing quality is nice and perfectly flat.

- Standard Equipment: Pneumatic thread trimmer
 Pneumatic presser foot lifter
 Direct-drive servo motor
 Condensed stitching device



S5



S007KD-W815A-356/SRL/UTT/DSK□ 3 5 5.6 1.4 ~ 4.2 0.8 ~ 1.4 5/7 UYX128GAS#10 4000



S007KD-W815A-356/SRL/UTT/DSKH1

左切刀修布下擺車縫

左切刀修布邊/下擺車縫工程適用於小筒型繃縫車

BOTTOM HEMMING WITH LEFT SIDE FABRIC TRIMMER

Left edge trimmer designed for small cylinder machine with auto thread trimmer function.



F007K/KD SERIES FEATURES

全新人體工學，圓弧流線時尚的外型設計，使用方便順手，賞心悅目
Brand new design of fashionable and smooth appearance, easy to sew.



上夾線裝置

出刀迅速精準，夾線穩定

Upper Thread Holder

Newly designed auto trimmer trims precisely and stably.

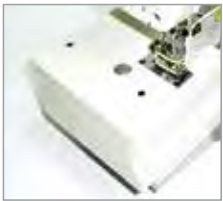

內縮式床台

縫製物更靠近機針，車縫定位精準，車縫時更加順暢就手

The Recessed Machine Bed

The sewing material is closer to the needle and the sewing is precise, which makes sewing operation easier and smoother.



拷克骨車縫附調整式進布誘導器，活動式壓腳，車縫適用性更廣

Cover seaming with adjustable folder, flexible presser foot, accommodate wider range of sewing items.



自動切線系列新設計氣/電動上下切刀組

出刀迅速穩定精準，切線俐落，輕順低噪音調整容易

Auto trimmer with newly designed pneumatic / electric trimming system trims precisely and stably, lower sound and easy to adjust.

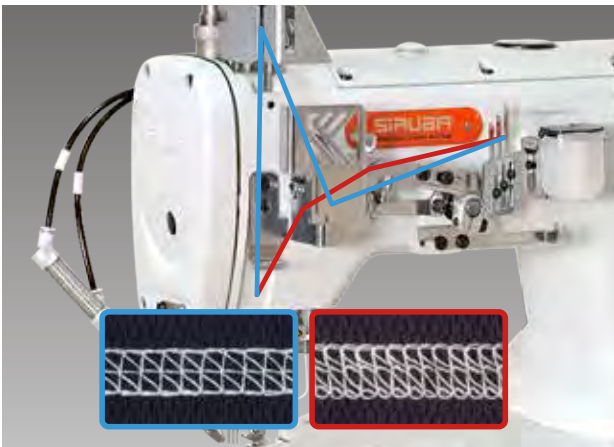

雙天秤挑線控線組

全新雙天秤挑線控線組的設計，縫製厚、薄布料皆適用，車縫適用範圍更廣，適用性更高

Dual Thread Take-up Mechanism

The brand new design of dual thread take-up lever thread tension combination is ideal for both heavy and light fabric. Sewing applicable range is wider and the applicability is higher.

— 中厚布料 (Medium heavy fabric)

— 薄布料 (Light fabric)

F1

F007K-W121-□□□/ FHA	2	4	4.0/ 4.8	1.6 ~ 4.2	0.5 ~ 1.3	5	UYX128GAS#10	6000
	3	5	5.6/ 6.4	1.6 ~ 4.2	0.5 ~ 1.3	5	UYX128GAS#10	6000
F007K-W122-□□□/ FHA	2	4	4.0/ 4.8	1.6 ~ 4.2	0.5 ~ 1.3	5	UYX128GAS#10	6000
	3	5	5.6/ 6.4	1.6 ~ 4.2	0.5 ~ 1.3	5	UYX128GAS#10	6000
F007K-W123-□□□/ FHA	2	4	4.0/ 4.8	1.6 ~ 4.2	0.5 ~ 1.3	5/7	UYX128GAS#10	6000
	3	5	5.6/ 6.4	1.6 ~ 4.2	0.5 ~ 1.3	5/7	UYX128GAS#10	6000
F007K-W162-□□□/ FHA	3	5	5.6/ 6.4	1.6 ~ 4.2	0.5 ~ 1.3	5/7	TVX5#14~16	6000
F007K-W162H-□□□/ FHA	3	5	5.6/ 6.4	6	0.5 ~ 1.3	5/7	TVX5#14~16	6000
F007KD-W121-□□□/ FHA/DF□	2	4	4.0/ 4.8	1.6 ~ 4.2	0.5 ~ 1.3	5	UYX128GAS#10	6000
	3	5	5.6/ 6.4	1.6 ~ 4.2	0.5 ~ 1.3	5	UYX128GAS#10	6000
F007KD-W122-□□□/ FHA/DF□	2	4	4.0/ 4.8	1.6 ~ 4.2	0.5 ~ 1.3	5	UYX128GAS#10	6000
	3	5	5.6/ 6.4	1.6 ~ 4.2	0.5 ~ 1.3	5	UYX128GAS#10	6000
F007KD-W123-□□□/ FHA/DF□	2	4	4.0/ 4.8	1.6 ~ 4.2	0.5 ~ 1.3	5/7	UYX128GAS#10	6000
	3	5	5.6/ 6.4	1.6 ~ 4.2	0.5 ~ 1.3	5/7	UYX128GAS#10	6000
F007KD-W162-□□□/ FHA/DF□	3	5	5.6/ 6.4	1.6 ~ 4.2	0.5 ~ 1.3	5/7	TVX5#14~16	6000
F007KD-W162H-□□□/ FHA/DF□	3	5	5.6/ 6.4	6	0.5 ~ 1.3	5/7	TVX5#14~16	6000



F007K-W121-356/FHA

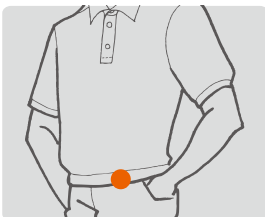

一般平縫 / 下擺車縫

本機型為雙面飾繃縫筒車之基本機型，可裝配附件進行多種功能車縫
例如：內衣褲、運動衫接縫及下擺車縫(附可調式下擺車縫組)

GENERAL SEAMING / BOTTOM HEMMING

Basic model of interlock stitch machine with double side cover-stitching. It is available for various sewing by optional devices. Such as plain seaming and bottom hemming for underwears, sportswears, etc... (equipped with adjustable hemming set)

W121 :	薄布料	Light material
W122 :	中厚布料	Medium material
W123 :	厚布料	Heavy material
W162 :	高行程	High needle bar stroke
W162H :	高行程 大針距(6mm)	High needle bar stroke Long stitch length (6mm)

選購配件 OPTIONAL DEVICE

UTG, UTH, UTJ, UTK, FL

F2



F007K(D)-W222-□□□/ FQ(DF□)	2	4	4.0/ 4.8	1.6 ~ 4.2	0.5 ~ 1.3	5	UYX128GAS#10	6000
	3	5	5.6/ 6.4	1.6 ~ 4.2	0.5 ~ 1.3	5	UYX128GAS#10	6000
F007K(D)-W222-□□□/ FFD(DF□)	2	4	4.0/ 4.8	1.6 ~ 4.2	0.5 ~ 1.3	5	UYX128GAS#10	6000
	3	5	5.6/ 6.4	1.6 ~ 4.2	0.5 ~ 1.3	5	UYX128GAS#10	6000
F007K(D)-W222-□□□/ FFP(DF□)	2	4	4.0/ 4.8	1.6 ~ 4.2	0.5 ~ 1.3	5	UYX128GAS#10	6000
	3	5	5.6/ 6.4	1.6 ~ 4.2	0.5 ~ 1.3	5	UYX128GAS#10	6000



F007K-W222-356/FQ/FEC



F007K-W222-356/FFD



F007K-W222-356/FFP



FQ

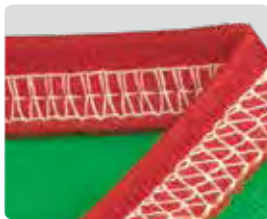

FQ

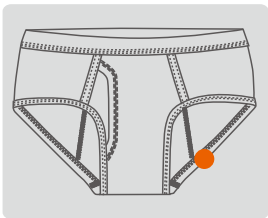

FFD/FFP



FFD/FFP

FQ:上帶滾邊車縫

適用於T恤、內衣褲之領口、褲管口等上帶滾邊之車縫工程，可加附電動(FEC)或氣動式(FAC)長切刀式切布條裝置，能將滾邊布條切斷，節省布條之用料增加車縫效率

FQ:TAPE BINDING

For tape binding on openings of leg or neck of underwears, T-shirts, etc... Also can attach electric(FEC) or pneumatic(FAC) tape cutter to save tape and increase sewing efficiency.

FFD / FFP:上帶滾邊車縫包覆鬆緊帶

上送帶裝置控制鬆緊帶張力，加上膝動控制鬆緊帶之左右移動，能有效讓鬆緊帶前後段與衣身車縫固定，適用於內褲之褲頭、褲腳之滾邊加鬆緊帶之車縫工程

FFD: 齒輪箱型精準張力控制

FFP: 彈簧片型簡易張力控制

FFD / FFP:TAPE BINDING WITH ELASTIC BAND

Top feeding device controls the elastic band's tension. Elastic band right-left position controller (by knee-pushing) sets the materials joining at the beginning and ending of waistband, leg opening of briefs...etc.

FFD: Gearbox type for accurate tension control

FFP: Spring type for simple tension control



◀ 以上機型可加裝
FNC, FSC:
電眼型後切刀附直驅馬達

Optional device for the above models

FNC, FSC:
Sensor type rear cutter with direct-drive servo motor

選購配件 OPTIONAL DEVICE

FA, LF-A, FAC, FEC, LS-A

F3



F007K-W222-240-4/FSM	3	8	4.0	1.6 ~ 4.2	0.5 ~ 1.3	5	UYX128GAS#10	2500
F007K-W222-248-4/FSM	3	8	4.8	1.6 ~ 4.2	0.5 ~ 1.3	5	UYX128GAS#10	2500
F007K-W222-364-4/FSM	4	9	6.4	1.6 ~ 4.2	0.5 ~ 1.3	5	UYX128GAS#10	2500



F007K-W222-356/FSM



花飾滾邊車縫

用於T恤衫、襯衫等領口、下擺、袖口等花飾滾邊車縫。附有四組花飾凸輪可變化成數百種車縫花樣。

ORNAMENTAL TAPE BINDING

Suitable for ornamental tape binding of neck band, bottom or cuff of T-shirts, shirts, etc...

選購配件 OPTIONAL DEVICE

FA

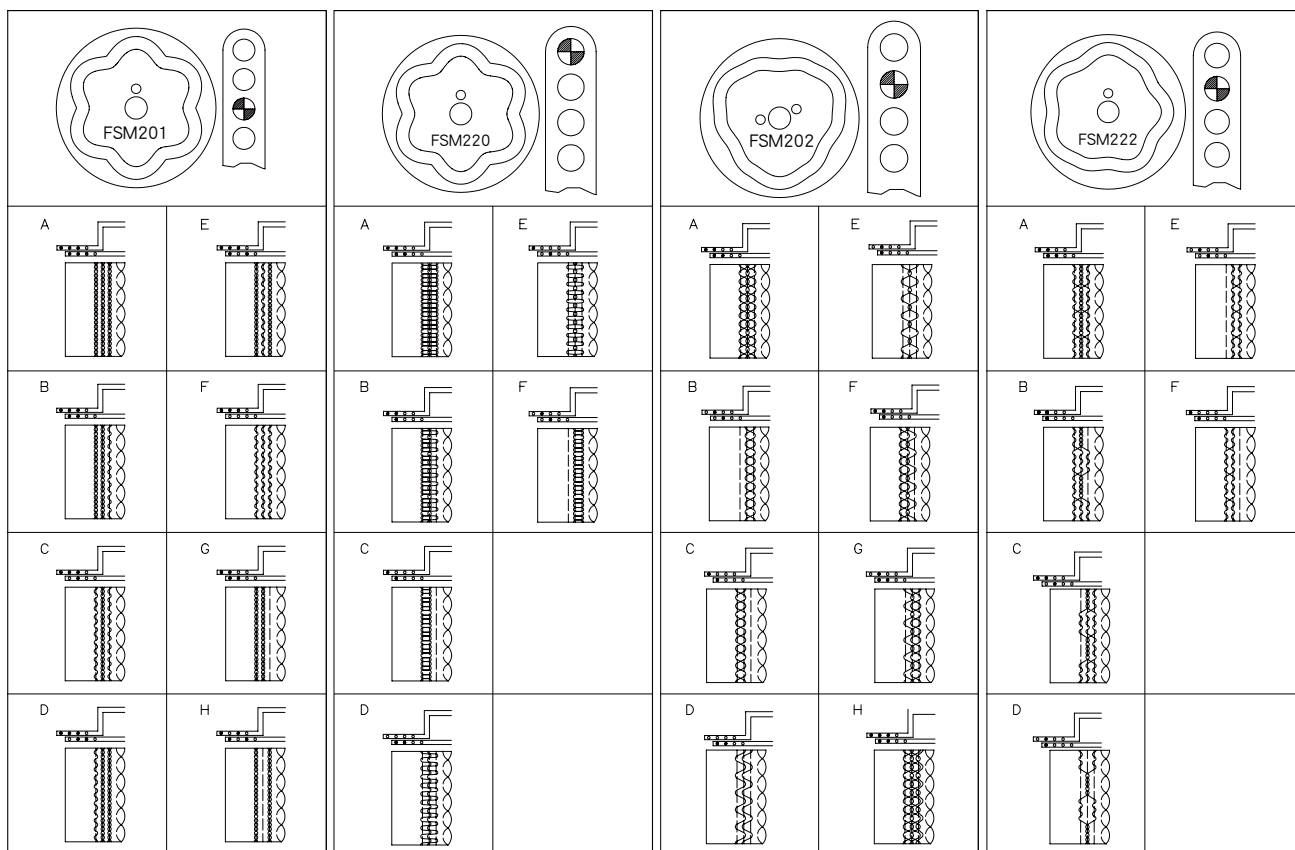

F4

								
F007K-W322-□□□/FDC	3	5	5.6/ 6.4	1.6 ~ 4.2	0.5 ~ 1.3	5	UYX128GAS#10	6000
F007KD-W322-□□□/FDC/DF□	3	5	5.6/ 6.4	1.6 ~ 4.2	0.5 ~ 1.3	5	UYX128GAS#10	6000
F007K-W322-□□□/FDE	3	5	5.6/ 6.4	1.6 ~ 4.2	0.5 ~ 1.3	5	UYX128GAS#10	6000
F007KD-W322-□□□/FDE/DF□	3	5	5.6/ 6.4	1.6 ~ 4.2	0.5 ~ 1.3	5	UYX128GAS#10	6000



F007K-W222-356/FDC



F007KD-W322-356/FDE/UTJ/DF□

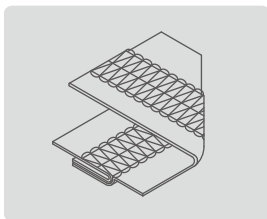

FDC



FDC

拷克倒骨蓋縫

FDC 倒骨型：適用於4線包縫之蓋縫

FDE 立骨型：適用於3線包縫之蓋縫

配件盒另附有FDC倒骨規格之牛角(導布片)

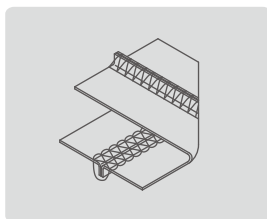

FDE

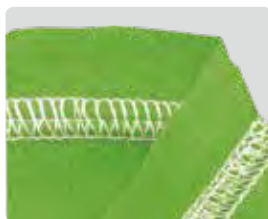

FDE

OVERLOCK-SEAM COVERING STITCH

FDC Fold-down type : For 4-thread overlock-seam covering stitch.

FDE Flattening type : For 3-thread overlock-seam covering stitch, and an extra guide of overlock-seam (FDC specification, fold-down type) is included in the accessory box.

選購配件 OPTIONAL DEVICE
UTG , UTH , UTJ , UTK

F5



Model	2	4	4.0/ 4.8	1.6 ~ 4.2	0.5 ~ 1.3	5	UYX128GAS#10	4500
F007K-W512-□□□/FE	2	4	4.0/ 4.8	1.6 ~ 4.2	0.5 ~ 1.3	5	UYX128GAS#10	4500
	3	5	5.6/ 6.4	1.6 ~ 4.2	0.5 ~ 1.3	5	UYX128GAS#10	4500
F007K-W512-□□□/FFC	2	4	4.0/ 4.8	1.6 ~ 4.2	0.5 ~ 1.3	5	UYX128GAS#10	4500
	3	5	5.6/ 6.4	1.6 ~ 4.2	0.5 ~ 1.3	5	UYX128GAS#10	4500
F007K-W512-□□□/SMK	2	4	4.0/ 4.8	1.6 ~ 4.2	0.5 ~ 1.3	5	UYX128GAS#10	4500
	3	5	5.6/ 6.4	1.6 ~ 4.2	0.5 ~ 1.3	5	UYX128GAS#10	4500
F007K-W512-□□□/STC	2	4	4.0/ 4.8	1.6 ~ 4.2	0.5 ~ 1.3	5	UYX128GAS#10	4500
	3	5	5.6/ 6.4	1.6 ~ 4.2	0.5 ~ 1.3	5	UYX128GAS#10	4500



F007K-W512-356/FE



F007K-W512-356/FFC

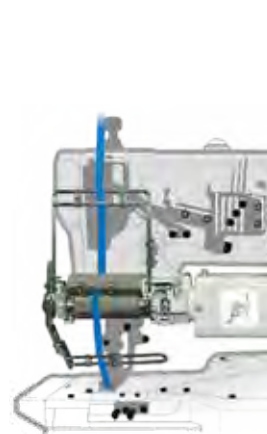

SMK



STC

鬆緊帶 / 蕾絲鬆緊帶上帶車

經由上送帶裝置 · 控制長度與張力,提高車縫品質 · 如女用內衣褲之鬆緊帶或蕾絲鬆緊帶車縫

FFC: 機械式送帶

FE: 簡易電子式送帶

SMK: 電子計數式送帶

SMK1-C-01 附定位器 · 適合簡易伺服或離合器馬達

SMK1-C-02 以中繼線 · 連接伺服馬達

STC: 張力控制式送帶

STC1-U-01 附定位器 · 適合簡易伺服或離合器馬達

STC1-U-02 以中繼線 · 連接伺服馬達

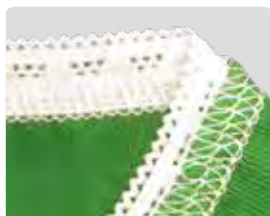
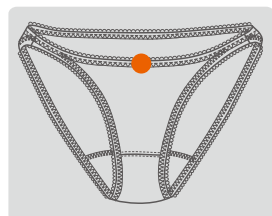

ELASTIC / LACE ATTACHING

Top feeding devices ensure even length and tension controlled by electric digital controller, for elastic or lace attaching smoothly and properly on women's underwears.

FFC: Mechanic type tape feeding.

FE: Simple electric type tape feeding.

SMK: Electric metering type tape feeding

SMK1-C-01 with synchronizer for simple servo motor or clutch motor

SMK1-C-02 Connected to servo motor by encoder cable

STC: Tension sensor type tape feeding

STC1-U-01 with synchronizer for simple servo motor or clutch motor

STC1-U-02 Connected to servo motor by encoder cable

選購配件 OPTIONAL DEVICE

FAC, FEC, LF-A, LS-A

F6



F007K-W522-□□□/FR/FFC	2	4	4.0/ 4.8	1.6 ~ 4.2	0.5 ~ 1.3	5	UYX128GAS#10	4500
	3	5	5.6/ 6.4	1.6 ~ 4.2	0.5 ~ 1.3	5	UYX128GAS#10	4500
F007K-W522-□□□/FR/FE	2	4	4.0/ 4.8	1.6 ~ 4.2	0.5 ~ 1.3	5	UYX128GAS#10	4500
	3	5	5.6/ 6.4	1.6 ~ 4.2	0.5 ~ 1.3	5	UYX128GAS#10	4500
F007K-W522-□□□/FR/SMK	2	4	4.0/ 4.8	1.6 ~ 4.2	0.5 ~ 1.3	5	UYX128GAS#10	4500
	3	5	5.6/ 6.4	1.6 ~ 4.2	0.5 ~ 1.3	5	UYX128GAS#10	4500
F007K-W522-□□□/FR/STC	2	4	4.0/ 4.8	1.6 ~ 4.2	0.5 ~ 1.3	5	UYX128GAS#10	4500
	3	5	5.6/ 6.4	1.6 ~ 4.2	0.5 ~ 1.3	5	UYX128GAS#10	4500



F007K-W522-240/FR/FE/FAC

鬆緊帶 / 蕾絲鬆緊帶上帶車縫附右切刀

由上送帶裝置，控制長度與張力，附右切刀修布裝置，能於車縫前將布修齊，更能提高車縫品質，如女用內衣褲之鬆緊帶或蕾絲鬆緊帶車縫

FFC: 機械式送帶

FE: 簡易電子式送帶

SMK: SMK1-C-01 附定位器，適合簡易伺服或離合器馬達
SMK1-C-02 以中繼線，連接伺服馬達張力控制式送帶

STC: 張力控制式送帶

STC1-U-01 附定位器，適合簡易伺服或離合器馬達

STC1-U-02 以中繼線，連接伺服馬達張力控制式送帶

ELASTIC / LACE ATTACHING WITH RIGHT FABRIC TRIMMER

Top feeding devices ensure even length and tension controlled by electric digital controller, with right side fabric trimmer for elastic or lace attaching smoothly and properly on women's underwears.

FFC: Mechanic type tape feeding.

FE: Simple electric type tape feeding.

SMK: Electric metering type tape feeding

SMK1-C-01 with synchronizer for simple servo motor or clutch motor

SMK1-C-02 Connected to servo motor by encoder cable

STC: Tension sensor type tape feeding

STC1-U-01 with synchronizer for simple servo motor or clutch motor

STC1-U-02 Connected to servo motor by encoder cable

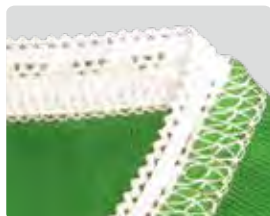
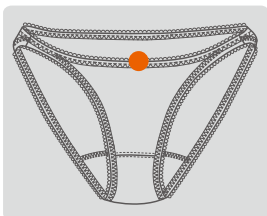

SMK



STC

選購配件 OPTIONAL DEVICE

FAC, FEC, LF-A, LS-A



F007K-W522-240/FR/FQS

細滾邊車縫 (右切刀機型附側送小喇)

本機型適用於女性內褲或丁字褲之細滾邊車縫，在滾邊之前先經右切刀修布，避免發生爆縫問題，可搭配以下送帶裝置

SMK: 電子計數式送帶

SMK1-E-01 附定位器 · 適合簡易伺服或離合器馬達

SMK1-E-02 以中繼線 · 連接伺服馬達張力控制式送帶

STC: 張力控制式送帶

STC1-S-01 附定位器 · 適合簡易伺服或離合器馬達

STC1-S-02 以中繼線 · 連接伺服馬達



FINE TAPE BINDING (RIGHT TRIMMER MODEL WITH SMALL BINDER)

This machine is applicable for fine tape binding of women's underwear or T-string. Before tape binding, the fabric edge is trimmed by the right trimmer. This solves the problem of bad binding, which the tape is not sewn on the fabric. The below tape feeding devices are applicable.

SMK: Electric metering type tape feeding

SMK1-E-01 with synchronizer for simple servo motor or clutch motor

SMK1-E-02 Connected to servo motor by encoder cable

STC: Tension sensor type tape feeding

STC1-S-01 with synchronizer for simple servo motor or clutch motor

STC1-S-02 Connected to servo motor by encoder cable

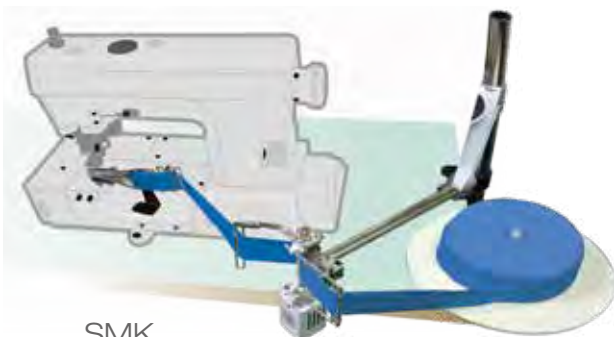

SMK



STC

選購配件 OPTIONAL DEVICE

FAC, FEC, LF-A, LS-A, TUA

F8



F007K-U122-232/FP	2	3	3.2	1.6 ~ 4.2	0.5 ~ 1.3	7	TVX5#14	6000
F007KD-U122-232/FP/DF□	2	3	3.2	1.6~4.2	0.5 ~ 1.3	7	TVX5#14	6000



F007K-U122-232/FP

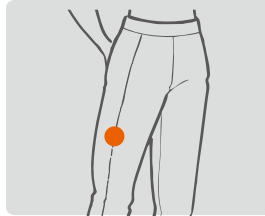

折線條車縫

本機種適用於運動服、牛仔或其他服飾之凸面折線條車縫，車縫時可於折線條內另加縫線繩，以增加凸線條之立體感和裝飾效果

PINTUCK SEAMING

To sew a decorative convex stripe on sportswears, jeans or other clothes, can also add extra stripe inside convex to increase the effects of convexity and decoration.

F9



F007K-U613-256/FBP	2	3	5.6	1.6 ~ 4.2	0.5 ~ 1.3	7	TVX5 #14 ~ #18	6000
F007K-U613-264/FBP	2	3	6.4	1.6 ~ 4.2	0.5 ~ 1.3	7	TVX5 #14 ~ #18	6000
F007KD-U613-256/FBP/DF□	2	3	5.6	1.6 ~ 4.2	0.5 ~ 1.3	7	TVX5 #14 ~ #18	6000
F007KD-U613-264/FBP/DF□	2	3	6.4	1.6 ~ 4.2	0.5 ~ 1.3	7	TVX5 #14 ~ #18	6000



F007K-U613-256/FBP

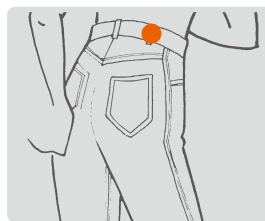

褲耳車縫

利用已裁好之等寬布條連續快速製作褲耳

BELT-LOOP SEAMING

Mass production for belt loop by using stripped tape.

選購配件 OPTIONAL DEVICE

LF-A, LS-A

F10



F007K-U712(A)-264/FSP	2	4	6.4	1.6 ~ 4.2	0.5 ~ 1.3	5	DVX43#11 ~ #16	6000
F007KD-U712(A)-264/FSP/DF□	2	4	6.4	1.6 ~ 4.2	0.5 ~ 1.3	5	DVX43 #11 ~ #16	6000
F007K-U712-496/FSS	4	6	3.2	1.6 ~ 4.2	0.5 ~ 1.3	5	UYX128GAS#10	6000
F007K-U712-4111/FSS	4	6	3.7	1.6 ~ 4.2	0.5 ~ 1.3	5	UYX128GAS#10	6000
F007KD-U712-496/FSS/DF□	4	6	3.2	1.6 ~ 4.2	0.5 ~ 1.3	5	UYX128GAS#10	6000
F007KD-U712-4111/FSS/DF□	4	6	3.7	1.6 ~ 4.2	0.5 ~ 1.3	5	UYX128GAS#10	6000



F007K-U712-264/FSP



F007K-U712-496/FSS

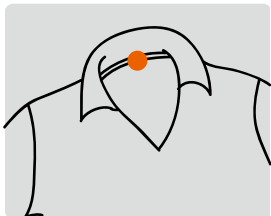

FSP

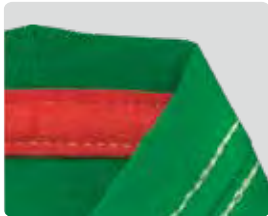

FSP

布條車縫 (雙針雙勾)

本機系將拷克後之拷克骨縫上布條以補強及增加美觀之用，如男內褲、休閒褲等之車縫

U712: 成品寬度10mm

U712A: 成品寬度12mm

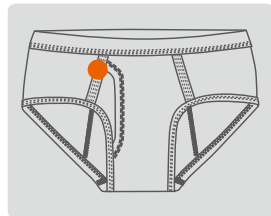

FSP/FSS



FSS

TAPE ATTACHING (TWO NEEDLE , TWO LOOPER)

This machine is specially for tape binding on cross seaming of men's briefs or sportswears to strengthen plain seam and for ornamental purpose.

U712: finished tape width 10mm

U712A: finished tape width 12mm

布條車縫 (四針雙勾)

本機系將拷克後之拷克骨縫上布條以補強及增加美觀之用，如男內褲、休閒褲等之車縫

TAPE ATTACHING (FOUR NEEDLE , TWO LOOPER)

This machine is specially for tape binding on cross seaming of men's briefs or sportswears to strengthen plain seam and for ornamental purpose.

選購配件 OPTIONAL DEVICE

LF-A , LS-A

F11



F007K-U712-264/FSR	2	4	6.4	1.6 ~ 4.2	0.5 ~ 1.3	5	TVX7 #12 ~ #14	6000
F007KD-U712-264/FSR/DF□	2	4	6.4	1.6 ~ 4.2	0.5 ~ 1.3	5	TVX7 #12 ~ #14	6000



F007K-U712-264/FSR

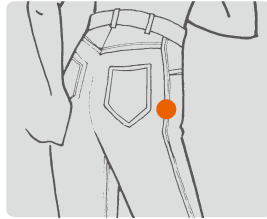

捲疊縫

本機種設計特殊之左右齒差動方式，能使捲疊縫縫紉更順暢車縫後左右二片布均一無長短之虞，適用於西褲、休閒褲、牛仔褲薄至厚布料等之捲邊疊縫

LAP SEAMING

Differential ratio of left and right feed dog can be adjusted separately for lap seaming to ensure symmetrical length to both left and right fabric. Applicable to trousers, casual pants and jeans, etc...

F12



F007K-W722-388/FY	3	7	8.8	1.6 ~ 4.2	0.5 ~ 1.3	5	TVX7 #12	6000
F007KD-W722-388/FY/DF□	3	7	8.8	1.6 ~ 4.2	0.5 ~ 1.3	5	TVX7 #12	6000



F007K-W722-388/FY

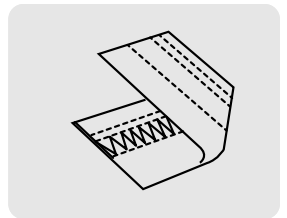
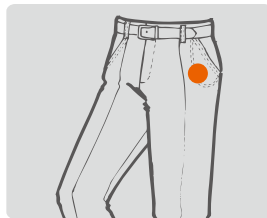

褲袋裡車縫

本機為三針三勾針一上叉，可同時縫合褲袋內裡與表布並強化車縫處之牢固，增加美觀提高效率，適用於西褲、工作褲等

POCKET LINING SEAMING

This is a 3 needles 3 loopers 1 spreader machine, and special for seaming the shell fabric and lining of pocket in trousers or work pants in simple operation to increase sewing quality and efficiency.

F13



F007K-W922-456/FW	4	6	5.6	1.6 ~ 4.2	0.5 ~ 1.3	5	SMX1014B#10	6000
F007K-W922-460/FW	4	6	6.0	1.6 ~ 4.2	0.5 ~ 1.3	5	SMX1014B#10	6000
F007K-W922-464/FW	4	6	6.4	1.6 ~ 4.2	0.5 ~ 1.3	5	SMX1014B#10	6000
F007KD-W922-456/FW/DF□	4	6	5.6	1.6 ~ 4.2	0.5 ~ 1.3	5	SMX1014B#10	6000
F007KD-W922-460/FW/DF□	4	6	6.0	1.6 ~ 4.2	0.5 ~ 1.3	5	SMX1014B#10	6000
F007KD-W922-464/FW/DF□	4	6	6.4	1.6 ~ 4.2	0.5 ~ 1.3	5	SMX1014B#10	6000



F007K-W922-456/FW

四針六線搭接縫車縫

適用於一般內衣褲二片布接縫處之接縫和補強。附有專屬之導邊，可使二片布順暢縫合。

FOUR-NEEDLE FLAT SEAMING

For flat seaming 2 pieces of fabric. Equipped with fabric guide for easy operation.

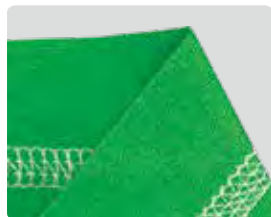
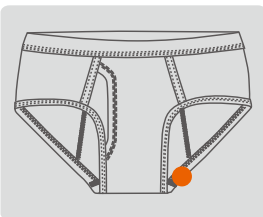
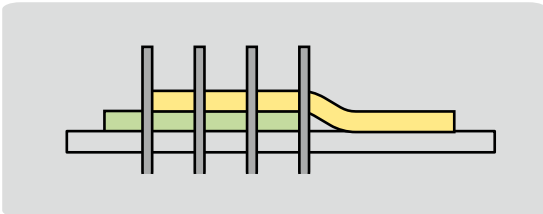

FW-4A

FW- 4	四針·無假針·適用上網線切線刀 4 needles Without retainer, applicable to upper thread trimmer
FW- 4A	配特殊針板 E1838P·適合車縫運動鞋裝飾線 With special needle plate E1838P, applicable to shoe decoration
FW- 5	四針·有假針·不適用上網線切線刀 4 needles with retainer, not applicable to upper thread trimmer

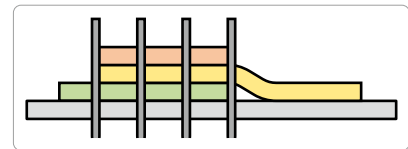

FWP

附喇叭 (B417R) 與導帶架

With folder (B417R) and tape guide.

選購配件 OPTIONAL DEVICE
UTH, UTK

F14



Model	2	4	4.0/ 4.8	1.6 ~ 4.2	0.5 ~ 1.3	1~5.5	5	UYX128GAS#10	4500
F007KD-W121-□□□/FFT/FHA/DF□	3	5	5.6/ 6.4	1.6 ~ 4.2	0.5 ~ 1.3	1~5.5	5	UYX128GAS#10	4500
F007KD-W122-□□□/FFT/FHA/DF□	3	5	5.6/ 6.4	1.6 ~ 4.2	0.5 ~ 1.3	1~5.5	5	UYX128GAS#10	4500
F007KD-W131-□□□/FFT/FHA/DF□	3	5	5.6/ 6.4	1.6 ~ 4.2	0.5 ~ 1.3	1~5.5	5	UYX128GAS#10	4500
F007KD-W132-□□□/FFT/FHA/DF□	3	5	5.6/ 6.4	1.6 ~ 4.2	0.5 ~ 1.3	1~5.5	5	UYX128GAS#10	4500



FFT 上送布功能

專利優化前後移動送具之結構設計，有效送布行程大，車縫送布更穩定

FFT TOP FEEDING FUNCTION

Back and forth moving feed dog is designed by patent and improved mechanism. The effective feeding stroke is bigger, and fabric feeding is more stable.

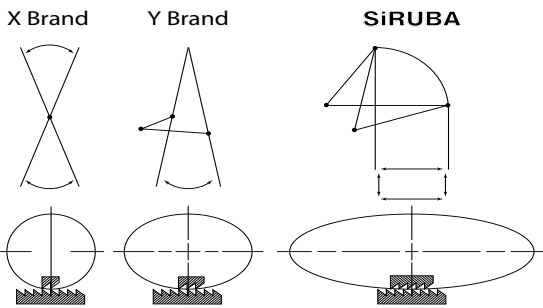

選購配件 OPTIONAL DEVICE
UTG , UTJ

F15



	2	3	4.8	1.6 ~ 4.2	0.5 ~ 1.3	1~5.5	5	UYX128GAS#10	4500
F007KD-U131-248/FFT/FHK/DF□	2	3	4.8	1.6 ~ 4.2	0.5 ~ 1.3	1~5.5	5	UYX128GAS#10	4500
F007KD-U131-256/FFT/FHK/DF□	2	3	5.6	1.6 ~ 4.2	0.5 ~ 1.3	1~5.5	5	UYX128GAS#10	4500
F007KD-U131-264/FFT/FHK/DF□	2	3	6.4	1.6 ~ 4.2	0.5 ~ 1.3	1~5.5	5	UYX128GAS#10	4500
F007KD-U132-248/FFT/FHK/DF□	2	3	4.8	1.6 ~ 4.2	0.5 ~ 1.3	1~5.5	5	UYX128GAS#10	4500
F007KD-U132-256/FFT/FHK/DF□	2	3	5.6	1.6 ~ 4.2	0.5 ~ 1.3	1~5.5	5	UYX128GAS#10	4500
F007KD-U132-264/FFT/FHK/DF□	2	3	6.4	1.6 ~ 4.2	0.5 ~ 1.3	1~5.5	5	UYX128GAS#10	4500



F007KD-U131-356/FFT/FHK/DF□

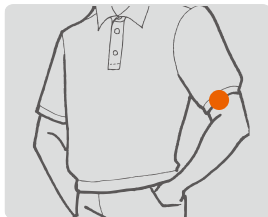

二針三線，袖口自動車縫裝置

1. T恤袖口、下擺氣動式自動送布、折布裝置，大幅節省人力及提升技術力
2. 可依客戶車縫需求自行調整下擺折邊寬度（附刻畫尺），及下折布料距左針之左右寬度調整，免裁切布料，節省材料成本
3. 電眼自動檢測送布、折邊、抬壓腳裝置，作業完成後自動停機
4. 最大產能約：6000件~7000件（袖口）/8小時

2 NEEDLE 3 THREAD AUTOMATIC SLEEVE HEMMING DEVICE

1. The pneumatic automatic feeding and folding device is for T-shirt sleeve hemming, which can save manpower and upgrade technique.
2. Customers can adjust the width of hemming folding edge and the horizontal width between folding fabric and left needle as required. Since there is no need to cut the fabric in advance material cost can be saved.
3. The electric eye can detect feeding, edging and presser foot lifter automatically. After finishing the action, the operation will stop automatically.
4. The maximum productivity: 6000 – 7000 pc (cuff)/ 8 hours.

DEVICE



CAR

氣動式密縫裝置 Pneumatic Condense Stitching Device (CAR/SAR)

膝動式密縫裝置 Manual Condense Stitching Device (CMR)

藉由縮短送具行程，在車縫起始或結束時進行密縫的功能，確保縫線不易脫落，提高車縫品質，基本車為腳踏板控制，電動和氣動控制為選配，本配件需更換專用規格組

By reducing the strokes of feed dog, at the beginning and the end of sewing, condense stitching reinforces the stitches. This enhances the sewing sturdiness and quality. Basic model is controlled by pedal. Electric and pneumatic controls are optional. Exclusive gauge sets is required.



SAR



CMR

Applicable Model	CAR (Pneumatic)	SAR (Pneumatic)	CMR (Manual)
C007K C007KD/DC□	√	X	√
S007K S007K/DS□	X	√	√

可自行組裝 self-installation : YES



CC

拷克倒骨蓋縫裝置 Overlock- Seam Covering (Fold-down Type)

1. 適中厚至厚布料經四線拷克車包縫後之飾縫
 2. 對於運動服，領子，衣襟，袖管之拷邊車縫後加以單面或雙面裝飾環縫，可增加服飾之美觀及車縫之牢固。利用導布片及壓具上之壓刀導縫，可避免車縫時彎曲不直
1. Overturned seam covering for medium to heavy fabric after 4 thread plain seaming.
2. Suitable for neck openings, sleeve, cuff or bottom of sportswears, T-shirts, etc... With fabric guide and special presser foot making sewing easy and more efficient.

可自行組裝 self-installation : YES

適用機型 applicable model : C007K/KD-W322, C007L-W325



CE

拷克倒 / 立骨蓋縫裝置

Overlock-Seam Covering (Fold-down / Flattening Type)

1. 適中厚布料經三線拷克車包縫後之飾縫
2. 對於運動服，領子，衣襟，袖管之拷邊車縫後加以單面或雙面裝飾環縫，可增加服飾之美觀及車縫之牢固。利用導布片及壓具上之壓刀導縫，可避免車縫彎曲不直

1. Bulging seam covering for medium fabric after 3 thread plain seaming.

2. Suitable for neck openings, sleeve, cuff or bottom of sportswears, T-shirts, etc... With fabric guide and special presser foot making sewing easy and more efficient.

可自行組裝 self-installation : YES

適用機型 applicable model : C007K/KD-W322, C007L-W325, C007L-U325

**CFC****鬆緊帶折縫 Elastic Hemming**

經由齒輪控制箱之控制，能有效控制鬆緊帶之鬆緊度，配合三折或二折折布喇叭及鬆緊帶壓縫，可精確完美的進行短褲、內褲等褲腳及褲頭之鬆緊帶折縫

Elastic hemming evenly length and elasticity is controlled by gear box. Great for seam covering with two or three plies hemming binder on elastic for waistband or leg opening of briefs and shorts's, etc...

可自行組裝 self-installation : NO

適用機型 applicable model : C007K-W542

**CH****下擺車縫 Hemming**

T恤、內衣及兒童服飾之下擺及袖口之車縫，可隨需要調整下擺飾縫組寬度，操作簡單快捷

Suitable for the bottom hemming of T-shirts, underwears, cuff of children's garments, etc...
Able to adjust the width of hemming set to fit demands, easy operation.

可自行組裝 self-installation : YES

適用機型 applicable model : C007K/KD-W121, C007K/KD-W122, C007K/KD-W123,
C007K/KD-W162, C007L-W125, C007L-W165, C007L-U125,
C007JP-W125

**CHK****下擺車縫 Hemming**

T恤、內衣及兒童服飾之下擺及袖口之車縫，可隨需要調整下擺飾縫組寬度，操作簡單快捷

CHK-A1 用於一般機型

CHK-UT 用於自動切線機型

Suitable for bottom hemming of T-shirts, underwears, cuff of children's garments, etc...

Able to adjust the width of hemming set to fit demands, easy operation.

CHK-A1 is for normal type machine

CHK-UT is for auto trimmer type machine

可自行組裝 self-installation : YES

適用機型 applicable model : C007KD-U131

**CHP****[二合一]氣動式下擺車縫 / 環型鬆緊帶折縫附左切刀修布邊功能****[2 IN 1]Pneumatic Hemming / Tubular Elastic Tape hemming With Left Edge Trimmer**

氣動式布料導邊器能將布料及鬆緊帶順暢的捲折，此外左切刀切齊後再進行縫紉，可增加包縫工程之品質與效率，適用於男內褲、運動褲等褲頭鬆緊帶包縫

With pneumatic driving folder to fold fabric and insert elastic smoothly, left hand side fabric trimming before hemming increases sewing quality & efficiency. For hemming sleeve opening and bottom of underwears, T-shirts, or sportswears, etc...

可自行組裝 self-installation : NO

適用機型 applicable model : C007K/KD-W822

**CY**



CL

後拉引滾輪 Rear Puller

1. 可拉車縫過後之布及鬆緊帶，使其不會產生車縫過後擠壓之毛病，以達車縫平順快速之效果
2. 本輔助件同時內附齒狀滾輪CL (CL19+ CL53) 與平面滾輪CLA (CL20+CL52)，供客戶依車縫布料之不同來選擇使用。一般布料用平面滾輪，但另車縫鬆緊帶或蕾絲鬆緊帶時，請用齒狀滾輪
3. 為能正確之校縫，機器裝配時會按實際需要裝齒狀滾輪與平面滾輪，但於配件盒附上另一組齒輪



CLA

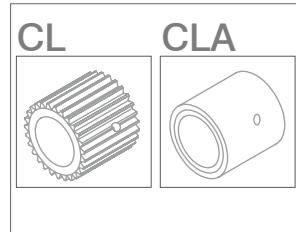

1. Pulls the fabric and elastic after sewing and makes sewing fast, flat and smooth without wrinkles.
2. The attachment includes both CL(CL19+CL53) and CLA(CL20+CL52). CLA is flat type for normal material, and CL is serrated type for elastic or lace, etc...
3. For fine-tuning purpose, the machine will be equipped with one rear puller depending on actual demand, the other one will be placed in the accessory box.

可自行組裝 self-installation : NO

適用機型 applicable model : C007K/KD



CQ

上帶滾邊車縫 Tape Binding

1. T 恤、內衣褲、兒童服飾等之領口、袖口和褲管口之包邊
2. 訂購內附CQ之機器內附FG組，但個別購買CQ裝置時則不另附FG組
3. 包邊喇叭之標準規格為入布寬度1-3/8"，出布時成三折，寬度為1/2"。若需訂購標準品以外之尺寸，請於訂購時特別註明，但交期及費用另計
4. 本輔助件有三種訂購方式：



CQA

1. For tape binding on openings of leg or neck of underwears, T-shirts, etc...
2. If purchased machine with CQ device, FG device will also be included. If only CQ device were purchased, no FG included.
3. Binder's standard tape size is 1-3/8" wide and finished size is 1/2" wide in 3 folds. Please remark if need another size when ordering, delivery and cost will be recalculated.
4. Ways to order the device:

機型 Model	CQ	FG	CQ 規格組 CQ Gauge Set	喇叭 Binder
C007KD-W222-240/CQ	√	√	√	√
C007KD-W222-240	×	×	√	×
C007KD-W222-240/CQ-P	√	√	√	×

可自行組裝 self-installation : YES

適用機型 applicable model : C007K/KD-W222



CR

右切刀修布及切布裝置 Right Hand Side Trimmer

修齊右邊或右下方多餘之布料，使衣物車縫後更加整齊美觀；附加吸布屑裝置更能保持工作環境乾淨

Right hand side waste fabric trimming with waste suction device makes fabric edge aligned to seam and keeps the working area clean.

可自行組裝 self-installation : NO

適用機型 applicable model : C007K-W522, C007K/KD-W532, C007L-W535, C007L-U535



CRL

左切刀修布裝置 Left Hand Side Trimmer

修齊二片布接縫之左下方多餘之布料，使衣物車縫後更加整齊美觀
Left hand side fabric trimming makes fabric edge aligned to seam.

可自行組裝 self-installation : NO

適用機型 applicable model : C007K/KD-W812(A), C007K/KD-W822, C007L-W815,
C007L-U815, C007L-W825, C007L-U815, C007JP-W815,
C007JP-U815, C007JP-W825, C007JP-U825



CSA

鐵桶式吸風馬達 Iron Case Suction

1. 雙吸馬力足 (前後吸) · 裝在車頭上比同類馬達大1 / 4的馬力
(後吸為切刀 · 前為漏斗式吹氣)
2. 噪音低 · 可比同類馬達降低5分貝
3. 溫度低 · 可比同類馬達降溫18%
4. 節省空間 · 裝在車板下比同類馬達節省10%的體積
5. 容易安裝 · 可比同類馬達少1 / 2安裝時間
6. 清理順暢 · 拆裝容易 · 集塵無漏洞
7. 風壓可視需求調整大小

1. Two-way suction (rear and front suction). 1/4 horsepower more than normal standard. (rear suction is for thread trimmer, front suction is for fabric waste)
2. Quiet. 5dB lower than normal standard.
3. Low temperature. 18% in celsius lower than normal standard.
4. Space efficiency. 10% space saved than normal standard.
5. Easy assembly. 50% time saved for assembly.
6. Easy to clean, easy to assemble/disassemble, completed dust collection.
7. Air pressure can be adjusted as needed.

可自行組裝 self-installation : YES

適用機型 applicable model : F007K/FR, C007K/CR, C007K/CRL



CSB

塑膠筒式吸風器 Plastic Tank Suction

1. 單吸馬力足 · 裝在車頭上比同類馬達大1 / 4的馬力 (適用後吸切刀)
2. 噪音低 · 可比同類馬達降低5分貝
3. 溫度低 · 可比同類馬達降溫10%
4. 節省空間 · 裝在車板下比同類馬達節省25%的體積
5. 容易安裝 · 可比同類馬達少1 / 4安裝時間
6. 清理順暢 · 拆裝容易 · 集塵無漏洞
7. 風壓可視需求調整大小

1. One-way suction, 1/4 horsepower more than other brands.
(for rear suction thread trimmer)
2. Quiet, 5dB lower than normal standard.
3. Low temperature. 10% lower than normal standard.
4. Space efficiency. 25% space saved than normal standard.
5. Easy assembly. 25% time saved for assembly.
6. Easy to clean, easy to assemble /disassemble, completed dust collection.
7. Air pressure can be adjusted as needed.

可自行組裝 self-installation : YES

適用機型 applicable model : F007K/FR, C007K/CR, C007K/CRL

**CW****四針六線環縫車縫裝置 Four-needle Flat Seaming**

適用於一般內衣褲二片布接縫處之接縫和補強，附有專屬之導邊器，可使二片布順暢縫合
For flat seaming 2 pieces of fabrics on men's briefs, fabric guide included.

可自行組裝 self-installation : YES
適用機型 applicable model : C007K/KD-W922

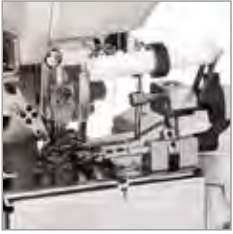
**CX****環型平織鬆緊帶包縫裝置 Pneumatic Elastic Inserting**

環型平織鬆緊帶或蕾絲鬆緊帶與衣物接縫，適用於男女內褲褲腰之鬆緊帶縫合，配合右切刀修布裝置更能提高縫製品質
For tubular elastic or lace waistband attaching on men's or women's briefs, with right hand side fabric trimming to increase sewing quality and efficiency.

可自行組裝 self-installation : YES
適用機型 applicable model : C007K/KD-W532,C007L-W535,C007L-U535

**CZ****氣動式環型羅紋鬆緊帶包縫裝置 Pneumatic Elastic Inserting**

男女用內褲之褲頭環型棉織鬆緊帶之包縫，本裝置需搭配CL及RLQ使用
Attaching tubular elastic tape onto waistband, suitable for briefs. For using this device, CL and RLQ must be equipped together.

可自行組裝 self-installation : YES
適用機型 applicable model : C007K/KD-W152

**CZP****膝動式環型羅紋鬆緊帶包縫裝置 Manual Elastic Inserting**

男女用內褲之褲頭環型棉織鬆緊帶之包縫，本裝置需搭配CL及RLQ使用
Attaching tubular elastic tape onto waistband, suitable for briefs. For using this device, CL and RLQ must be equipped together.

可自行組裝 self-installation : YES
適用機型 applicable model : C007K/KD-W152

**DCL** 1 2**DCK** 1 2**DFK** 1 2**DSK** 1 2**下軸型直驅伺服馬達 Lower main shaft type Direct-drive servo motor**

繡縫機模組化搭配直驅伺服馬達，多樣化的選擇，更有彈性

1 = 廠商代碼 + 版本代碼 2 = 版本代碼 + 功能代碼

Interlock machine equipped with the modularized direct-drive servo motors to be more flexible for diversification.

1 = Manufacturer code + version code 2 = Version code + Function code

可自行組裝 self-installation : YES
適用機型 applicable model : 全系列繡縫機 All Interlock Series



FA

側向電動送帶裝置 Side Electric Tape Feeding

1. 利用電子微動開關控制布條·鬆緊帶或蕾絲之輸送長度·使上帶車縫更加平順
 2. 送帶在控制箱右邊
1. With electronic switch to control the feeding length of tape, elastic, or lace to create smoother sewing.
 2. Tape feeding will be on the right hand side of the control box.

可自行組裝 self-installation : YES

適用機型 applicable model : C007K/CQ, C007K/CQA, C007KD/CQ, C007KD/CQA, F007K/FQ, F007K/FFD, F007K/FFP, F007K/FSM, F007KD/FQ, F007KD/FFP

F□C 後切刀系列 Rear Cutter Series



FAC



FEC



FNC/FSC



FNC



FSC

	操作模式 Operation Mode	切刀驅動 Cutter Driven by	電眼 Sensor	抬壓腳 Presser foot lifter	控制器 Controller	功能 Function
FAC	膝動 Knee	氣缸 + 機械閥 (氣動) Air cylinder + mechanical Valve (Pneumatic)	/	/	/	手動切刀 Manual Cutting
FEC	膝動 Knee	電磁鐵 (電動) Solenoid (Electric)	/	/	FE202-A 專用電控箱 Specific control box	手動切刀 Manual Cutting
FNC	自動/膝動 Auto/ Knee	氣缸 + 電磁閥 (氣動) Air cylinder + Solenoid (Pneumatic)	v	v	GD60-4-FK-220 伺服馬達驅動 Driven by servo motor	電眼偵測布邊 (類似700QD/ECA) The sensor checks the cloth edge. (Similar to 700QD/ECA)
FSC	自動/膝動 Auto/ Knee	氣缸 + 電磁閥 (氣動) Air cylinder + Solenoid (Pneumatic)	v	v	i70L-4-ME-220 伺服馬達驅動 附觸控面板 Driven by servo motor, with Control Panel	電眼偵測布邊·並且控制器以計數方式, 控制布帶的鬆緊度與餘留長度·適用比基尼車縫 Checking the cloth edge by sensor, and also the metering device controls the tape tension and the remained length. Applicable to bikini sewing.

可自行組裝 self-installation : NO

適用機型 applicable model : F007K/FQ, F007K/FE, F007K/SMK, F007K/STC, F007K/FR, F007K/FR/FQS,



FBP

褲耳車縫 Belt Loop Seaming

利用已裁好等寬之布條連續快速車縫褲耳

1. 一般W122機型可變換成FBP機型，只需訂購組件FBP- 256或FBP- 264，便可換成車褲耳之功能

2. 因所車縫布料不同而其所搭配之喇叭與針也會不同，訂購時請註明

Mass production for belt loop by using stripped tape.

1. Normal W122 type can be changed to FBP type with FBP-256 or FBP-264 for belt loop seaming.

2. Different size folders and needles may be required depends on different fabric. Please refer to the below table and remark when ordering.

針距 Needle Gauge	成品尺寸 Finished Good	喇叭代號 Folder No.	布料 Fabric
5.6mm	9 mm	FBP01A	男女西服 Suits for Men & Women
5.6mm	10mm	FBP01B	
6.4mm	12mm	FBP01C	牛仔 Jeans

可自行組裝 self-installation : YES

適用機型 applicable model : F007K-U613, F007KD-U613



FDC

拷克倒骨包縫裝置 Covering Seaming

1. 適中厚至厚布料經四線拷克車包縫後之飾縫

2. 對於運動服等衣物之領子、衣襟、袖管之拷邊包縫後加以單面或雙面裝飾環縫，可增加服飾之美觀及車縫之牢固。利用導布片及壓具壓刀之導縫，可避免車縫彎曲不直

1. Overturned seam covering for medium to heavy fabric after 4 thread plain seaming.

2. Suitable for neck openings, sleeve, cuff or bottom of sportswears, T-shirts, etc... With fabric guide and special presser foot making sewing easy and more efficient.

可自行組裝 self-installation : YES

適用機型 applicable model : F007K-W322, F007KD-W322



FDE

拷克立骨包縫裝置 Covering Seaming

1. 適中厚至厚布料經三線拷克車包縫後之飾縫

2. 對於運動服等衣物之領子、衣襟、袖管之拷邊包縫後加以單面或雙面裝飾環縫，可增加服飾之美觀及車縫之牢固。利用導布片及壓具壓刀之導縫，可避免車縫彎曲不直

1. Bulging seam covering for medium to heavy fabric after 3 thread plain seaming.

2. Suitable for neck openings, sleeve, cuff or bottom of sportswears, T-shirts, etc... With fabric guide and special presser foot making sewing easy and more efficient.

可自行組裝 self-installation : YES

適用機型 applicable model : F007K-W322, F007KD-W322



FE

電子式鬆緊帶控制裝置 Electric Type Elastic Feeding

1. 經由電子控制箱之數位設定，能有效控制鬆緊帶在設定好之鬆緊度輸送，以供車縫

2. 本裝置可接受鬆緊帶最大輸送寬度為2-1/2"

1. Elastic feeding ensures even length and elasticity, controlled by electronic digital control box.

2. Maximum feeding width of elastic is 2-1/2".

可自行組裝 self-installation : YES

適用機型 applicable model : F007K-W512, F007K-W522, C007K-W512, C007K-W522

**FFC****機械式鬆緊帶控制裝置 Mechanic Type Elastic Feeding**

1. 經由機體內機械帶動可自動輸送鬆緊帶，並經由齒輪箱控制器旋轉鈕，可依照衣服尺寸，微調設定車縫鬆緊帶之鬆緊程度
 2. 本裝置可接受鬆緊帶最大輸送寬度為2-1/2"
1. Elastic feeding ensures even length and elasticity controlled by gear set.
2. Maximum feeding width of elastic is 2-1/2".

可自行組裝 self-installation : No

適用機型 applicable model : F007K-W512, F007K-W522, C007K-W512, C007K-W522

**FFD****腰間或褲腳包縫控制鬆緊帶前後車縫裝置(機械式) Mechanic Type Elastic Feeding & Binding**

1. 短褲及男女用內褲褲頭或褲腳之鬆緊帶包縫，利用無段變速控制器，可精確調整鬆緊帶的鬆緊程度；運用操作簡便之膝動控制系統，控制鬆緊帶前後車縫，使車縫更完美
 2. 本裝置可接受鬆緊帶最大之尺寸為1 / 8" 到1 / 4" 之寬度
1. Elastic feeding ensures even length and elasticity controlled by gear set with elastic tape side-motion controller for sewing the beginning and ending of elastic tape onto waistband, leg opening of briefs, etc...
2. Maximum width of elastic is 1/8" to 1/4".

可自行組裝 self-installation : YES

適用機型 applicable model : F007K-W222

**FFP****腰間或褲腳包縫控制鬆緊帶前後車縫裝置(彈簧式) Mechanic Type Elastic Feeding & Binding (Leaf Spring)**

1. 短褲及男女用內褲褲頭或褲腳之鬆緊帶包縫，利用無段變速控制器，可精確調整鬆緊帶的鬆緊程度；運用操作簡便之膝動控制系統，控制鬆緊帶前後車縫，使車縫更完美
 2. 本裝置可接受鬆緊帶最大之尺寸為1 / 8" 到1 / 4" 之寬度
1. Elastic feeding ensures even length and elasticity controlled by leaf spring with elastic tape side-motion controller for sewing the beginning and ending of elastic tape onto waistband, leg opening of briefs, etc...
2. Maximum width of elastic is 1/8" to 1/4".

可自行組裝 self-installation : YES

適用機型 applicable model : F007K-W222, F007KD-W222

**FHA****下擺車縫 Hemming**

T恤、內衣、兒童服飾之下擺車縫；可隨需要調整下擺寬度，操作簡單
Suitable for bottom hemming of T-shirts, underwears, cuff of children's garments, etc... Able to adjust the width of hemming set to meet different demands, easy operation.

可自行組裝 self-installation : YES

適用機型 applicable model : F007K-W121, F007K-W122, F007K-W123, F007K-W162
F007KD-W121, F007KD-W122, F007KD-W123, F007KD-W162



FHK

二針三線·袖口自動車縫裝置 2 Needle 3 Thread Automatic Sleeve Hemming Device

1. T恤袖口、下擺氣動式自動送布、折布裝置·大幅節省人力及提升技術力
 2. 可依客戶車縫需求自行調整下擺折邊寬度 (附刻畫尺) · 下折布料距左針之左右寬度調整免裁切布料·節省材料成本
 3. 電眼自動檢測送布、折邊、抬壓腳裝置·作業完成後自動停機
 4. 最大產能約：6000件~7000件 (袖口) / 8小時
- 1.The pneumatic automatic feeding and folding device is for T-shirts sleeve hemming, which can save manpower and upgrade technique.
- 2.Customers can adjust the width of hemming folding edge and the horizontal width between folding fabric and left needle as required. Since there is no need to cut the fabric in advance material cost can be saved.
- 3.The electric eye can detect feeding, edging and presser foot lifter automatically. After finishing the action, the operation will stop automatically.
- 4.The maximum productivity: 6000 – 7000 pc (cuff)/ 8 hours.

可自行組裝 self-installation : NO

適用機型 applicable model : F007KD-U131, F007KD-U132



FL

後拉滾輪裝置 Rear Puller

適用於薄到中厚布車縫如：床單、被套、毛巾等 (較厚的硬滑布類不可適用) · 另附一組可調式下擺車縫組FHA (K)

Suitable for light to medium fabric, such as bedsheets, quilts, towels etc. With one set of adjustable bottom hemming device, FHA(K). (not suitable for the hard and slip fabric which is much heavy)

可自行組裝 self-installation : NO

適用機型 applicable model : F007K-W121/FHA, F007K-W122/FHA, F007K-W123/FHA,
F007K-W162/FHA, F007K-W222/FQ
F007KD-W121/FHA, F007KD-W122/FHA, F007KD-W123/FHA,
F007KD-W162/FHA, F007KD-W222/FQ



FP

折線條裝置 Crinkle Seaming

運動服裝·牛仔服飾或其他服飾之凸面折線條車縫·車縫時可於折線條內另加縫線繩·以增加凸線條之立體感和裝飾效果

To sew a decorative convex stripe on sportswears, jeans or other clothes, can also add extra stripe inside convex to increase the effects of convexity and decoration.

可自行組裝 self-installation : YES

適用機型 applicable model : F007K-U122-232, F007KD-U122-232



FQ

上帶滾邊車縫 Tape Binding

1. T恤、內衣褲、兒童服飾等之襯帶或包邊車縫
2. 本裝置與機器一起訂購時會加附FG組·但個別購買FQ元件時則不另附FG組
3. 喇叭標準規格為入布寬度1-3/8" · 出布寬度為1 / 2" · 捲成三折·若需要標準品以外之尺寸·請訂購時特別註明·但交期和費用另計
4. 本裝置有三種訂購方式：

1. For tape binding on openings of leg or underwear, T-shirt, etc...
2. If purchased machine with FQ, we will also attach FG. If purchase FQ device only, no FG attached.
3. Binder's standard opening size is 1-3/8" wide and finished size is 1/2" wide in 3 folds. Please remark if need another size when ordering, delivery date and cost will be re-calculated.
4. Ways to order the device:

機型 Model	FQ	FG	FQ 規格組 FQ Gauge Set	喇叭 Binder
F007K-W222-240/FQ	√	√	√	√
F007K-W222-240	X	X	√	X
F007K-W222-240/FQP	√	√	√	X

可自行組裝 self-installation : YES

適用機型 applicable model : F007K-W222, F007KD-W222

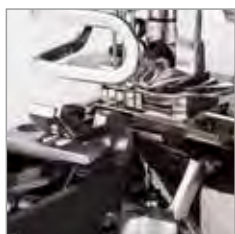

FR

右切刀修布裝置 Right Hand Side Trimmer

修齊兩片布接縫之下方多餘之布料，使車縫品質更加美觀

Right hand side waste fabric trimming, ensures better sewing quality.

可自行組裝 self-installation : NO

適用機型 applicable model : F007K-W522



FSM 花飾滾邊車縫 Ornamental Tape Binding

適用於T恤衫、襯衫等領口及下擺、袖口等花飾滾邊車縫，附有四組花飾凸輪可變化成數百種車縫花樣

Suitable for ornamental tape binding of neck band, bottom or cuff of T-shirts, shirts, etc... Four sets of cam create hundreds of patterns.

可自行組裝 self-installation : NO

適用機型 applicable model : F007K-W222, F007KD-W222



FSP

雙勾針上布條裝置 Double Looper Tape Binding

雙針雙勾針布條貼縫裝置，例如男內褲門襟

This device is specially designed for tape binding on cross seaming of men's briefs or sportswears.

壓具代碼 Presser Foot Code	入布寬度 Tape Width	出布寬度 Finish Width	適用機型 Applicable Model
P5118 (含喇叭) P5118 (binder included)	25mm	12mm	F007K(D)-U712A
P5117 (含喇叭) P5117 (binder included)	21mm	10mm	F007K(D)-U712

可自行組裝 self-installation : NO

適用機型 applicable model : F007K-U712, F007KD-U712

**FSR****捲疊縫 Lap Seaming**

本機種設計特殊之左右齒差動方式，能使捲疊縫縫紉更順暢，車縫後左右兩片均一無長短之虞；適用於西褲、休閒褲、牛仔褲薄至厚布料等之捲邊疊縫

Differential ratio of left and right feed dog can be adjusted separately for lap seaming to ensure symmetrical length to both left and right fabric. Applicable to trousers, casual pants and jeans, etc...

可自行組裝 self-installation : NO

適用機型 applicable model : F007K-U712, F007KD-U712

**FW****FWP****四針六線環縫車縫裝置 Four-needle Flat Seaming**

用於一般內衣褲二片布接縫處之接縫和補強，無需先經由拷克車拷邊再飾縫，牢固美觀，可附加喇叭 (B417R) 做貼帶補強用組件代號FWP

For flat seaming 2 pieces of fabric, equipped with fabric guide for easy operation.

FWP: Folder(B417R) is optional, for tape attaching.

可自行組裝 self-installation : NO

適用機型 applicable model : F007K-W922, F007KD-W922

**FY****褲袋裡布車縫 Pocket Lining Seaming**

用於褲袋之縫製，三針三勾一上叉針可強化縫合，增加產品之牢固。西服、工作服等衣袋和褲袋內裡之縫紉工程

This is a 3 needles 3 loopers 1 spreader machine, and special for seaming the shell fabric and lining of pocket in trousers or working pants in simple operation to increase sewing quality and efficiency.

可自行組裝 self-installation : NO

適用機型 applicable model : F007K-W722, F007KD-W722

**LFA-A□****直向電動送帶裝置 Electric Tape Feeding Device**

利用電子馬達帶動鬆緊帶，使其放鬆到零鬆緊狀況，並可控制所需鬆緊帶之長短，使車縫時鬆緊度能一致

□代表電壓，1: 110V, 2: 220V

Elastic type is fed by electric motor to achieve zero tension. Elastic tape length can be easily adjusted to expect length to ensure elasticity consistency.

□=voltage, 1: 110V, 2: 220V

可自行組裝 self-installation : YES

適用機型 applicable model :

C007K/FE, C007K/FFC, C007K/CR/FE, C007K/CR/FFC, C007K/CR/FFC, C007KD/FE, C007KD/CR/FE, F007K/FE, F007K/FFC, F007K/FFD, C007KP/CR/FFC, F007K/FFP, F007K/FSP, F007K/FBP, F007K/FWP, F007K/FR/FE, F007K/FR/FFC, F007KD/FE, F007KD/FFP, F007KD/FSP, F007KD/FBP, F007KD/FWP



LF290 抖帶輪 Untangle Wheel

-A□

可選配安裝於LFA (送帶裝置) · 以逆轉的方式 · 抖動鬆緊帶 · 做為送帶前的處理
□代表電壓 · 1: 110V · 2: 220V

An optional device to be equipped with LFA (tape feeding device). Untangling the elastic tape by reverse rotation wheel is a pre-feeding process.

□=voltage, 1: 110V, 2: 220V

可自行組裝 self-installation : YES

適用機型 applicable model : MODEL w/LFA



LS-A 上方帶盤 Upper Tape Holder

置於上前方放布條或鬆緊帶

For top feeding tape or elastic.

可自行組裝 self-installation : YES

適用機型 applicable model :

C007K/FE, C007K/FFC, C007K/GR/FE, C007K/CR/FFC, C007KD/FE, C007KD/GR/FE, F007K/FE, F007K/FFC, F007K/FFD, F007K/FFP, F007K/FSP, F007K/FBP, F007K/FWP, F007K/FR/FE, F007K/FR/FFC, F007KD/FE, F007KD/FFP, F007KD/FSP, F007KD/FBP, F007KD/FWP



PCC 拷克倒骨蓋縫裝置 Overlock-Seam Covering (Fold-down Type)

1. 適中厚至厚布料經四線拷克車包縫後之飾縫
 2. 對於運動服、領子、衣襟、袖管之拷邊車縫後加以單面或雙面裝飾環縫 · 可增加服飾之美觀及車縫之牢固。利用導布片及壓具上之壓刀導縫 · 可避免車縫時彎曲不直
- 1.Overturned seam covering for medium to heavy fabric after 4 thread plain seaming.
2.Suitable for neck openings, sleeve, cuff or bottom of sportswears, T-shirts, etc...
With fabric guide and special presser foot, making sewing easy and more efficient.

可自行組裝 self-installation : YES

適用機型 applicable model : S007K all models, S007KD all models



PCD 拷克倒骨蓋縫裝置 Overlock-Seam Covering (Fold-down Type)

1. 適中厚布料經四線拷克車包縫後之飾縫
 2. 對於運動服、領子、衣襟、袖管之拷邊車縫後加以單面或雙面裝飾環縫 · 可增加服飾之美觀及車縫之牢固。利用導布片及壓具上之壓刀導縫 · 可避免車縫時彎曲不直
- 1.Overturned seam covering for medium fabric after 4 thread plain seaming.
2.Suitable for neck openings, sleeve, cuff or bottom of sportswears, T-shirts, etc...
With fabric guide and special presser foot, making sewing easy and more efficient.

可自行組裝 self-installation : YES

適用機型 applicable model : S007K all models, S007KD all models



PCE 拷克立骨蓋縫裝置 Overlock-seam Covering (Flattening Type)

1. 適中厚布料經三線拷克車包縫後之飾縫
 2. 對於運動服、領子、衣襟、袖管之拷邊車縫後加以單面或雙面裝飾環縫 · 可增加服飾之美觀及車縫之牢固。利用導布片及壓具上之壓刀導縫 · 可避免車縫彎曲不直
1. Bulging seam covering for medium fabric after 3 thread plain seaming.
2. Suitable for neck openings, sleeve, cuff or bottom of sportswears, T-shirts, etc...
With fabric guide and special presser foot making sewing easy and more efficient.

可自行組裝 self-installation : YES

適用機型 applicable model : S007K all models, S007KD all models



PCH

下擺車縫 Bottom Hemming

T恤、內衣及兒童服飾之下擺及袖口之車縫。可隨需要調整下擺飾縫組寬度。操作簡單快捷
Suitable for the bottom hemming of T-shirts, underwears, cuff of children's garments, etc...
Able to adjust the width of hemming set to fit demands, easy operation.

可自行組裝 self-installation : YES

適用機型 applicable model : S007K all models, S007KD all models



RL

筒型衣物撐開滾輪組(長輪) Tubular Extending Roller (Long Type)

專用於輔助筒型衣物之車縫

Especially used to assist with tubular cloth sewing.

可自行組裝 self-installation : YES

適用機型 applicable model : C007K/CY, C007KD/CY, C007L, C007JP



RLP

筒型衣物撐開滾輪組(短輪 + 斜輪) Tubular Extending Roller (Short+ Cone Type)

專用於輔助筒型衣物之車縫

Especially used to assist with tubular cloth sewing.

可自行組裝 self-installation : YES

適用機型 applicable model : C007K/CX, C007KD/CX



RLQ

筒型衣物撐開滾輪組 Tubular Extending Roller

專用於輔助筒型衣物之車縫

Especially used to assist with tubular cloth sewing.

可自行組裝 self-installation : YES

適用機型 applicable model : C007K/CZ, C007KD/CZ



SMK

電子計數式送帶 Electric Metering type tape feeding

SMK1 - □ - □

A: 包縫機 · 上送帶
Overlock, Top Feed

C: 繃縫機 · 上送帶
Interlock, Top Feed

D: 繃縫機 · 下送帶
Interlock, Bottom Feed

E: 繃縫機 · 側送帶
Interlock, Side Feed

01 附定位器 · 適合簡易伺服或離合器馬達
With synchronizer for simple servo motor or clutch motor

02 以中繼線 · 連接伺服馬達
Connected to servo motor by encoder cable

可自行組裝 self-installation : YES

適用機型 applicable model : C007K-W512, C007K/CR, F007W512, F007/CR



SRL

左切刀修布裝置(小筒用) Left Hand Side Trimmer (For Small Cylinder Bed)

修齊兩片布接縫左下方多餘之布料，使車縫後更加整齊美觀
Left edge trimmer makes fabric edge aligned to seam.

可自行組裝 self-installation : NO
適用機型 applicable model : S007KD-815



STC

張力控制式送帶 Tension sensor type tape feeding

STC1 - □ - □

U: 上送帶
Top Feed
B: 下送帶
Bottom Feed
S: 側送帶
Side Feed

O1 附定位器，適合簡易伺服或離合器馬達 With synchronizer for simple servo motor or clutch motor
O2 以中繼線，連接伺服馬達
Connected to servo motor by encoder cable

可自行組裝 self-installation : YES
適用機型 applicable model : C007K-W512, C007K/CR, F007-W512, F007/CR

UT□ 自動切線組 Automatic Thread Trimmer Set



上切
Top Trimmer

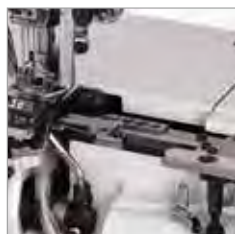

下切
Bottom Trimmer



夾線
Thread Gripping







吹風
Thread Blowing

機型 Model	代號 Code	功能 Function				驅動 Drive	
		上切 Top Trimmer	下切 Bottom Trimmer	夾線 Thread Gripping	吹風 Thread Blowing	氣動 Pneumatic	電動 Electrical
F007K F007KD	UTG	√	√		*	√	
	UTH		√	選配 Optional	√		
	UTJ	√	√				√
	UTK		√	√			
C007K C007KD C007L	UTP	√	√		*	√	
	UTQ		√	選配 Optional	√		
	UTR	√	√				√
	UTS		√	√			
S007K F007KD	UTT	√	√		*	√	
	UTU		√	選配 Optional	√		
	UTX	√	√				√
	UTY		√	√			



*配件盒附吹風管，客戶若不需上網線時，可自行將上切刀改為吹風
Thread blowing device is included in the accessory box. If the coverstich thread is not required, users may install blowing device instead of upper thread trimmer.

TABLE

桌板代號 Item No.	尺寸 / Size (mm)			說明 Description	適用機型 Applicable Model	備註 Remark
	長 Length	寬 Width	厚 Thickness			
C007L-T23	1200	540	45	半沉式 Semi-submerged	C007L, C007LX	
C007L-T25	1200	540	45	上乘式 Non-submerged	C007L, C007LX	
C007K-T23	1200	540	45	半沉式 Semi-submerged	C007K, C007KD, C007JP, S007K, S007KD	
C007K-T25	1200	540	45	上乘式 Non-submerged	C007K, C007KD, C007JP, S007K, S007KD	
C007K-T26	1200	540	45	半沉式 Semi-submerged	C007K/CFC	
F007K-T	1200	540	45	半沉式 Semi-submerged	F007K, F007KD	
F007K-T3	1200	540	45	全沉式 Fully-submerged	F007K, F007KD	
F007K-T1	1200	540	45	半沉式 Semi-submerged	F007K/FR, F007KD/FR	
F007K-T2	1200	540	45	上乘式 Semi-submerged	F007K/FFT/FHK	

DOUBLE CHAINSTITCH

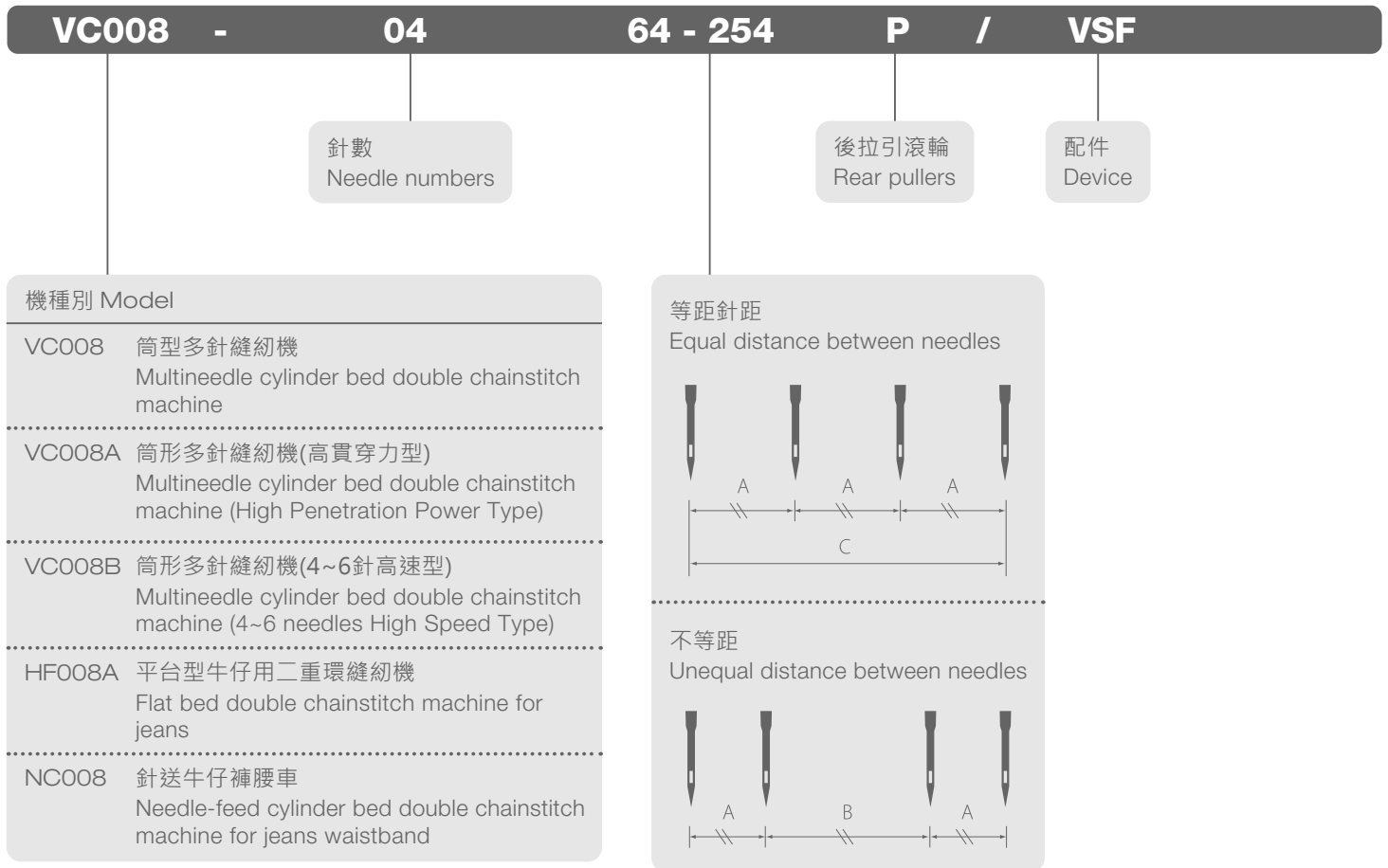

DOUBLE CHAINSTITCH DD SERVO MOTOR

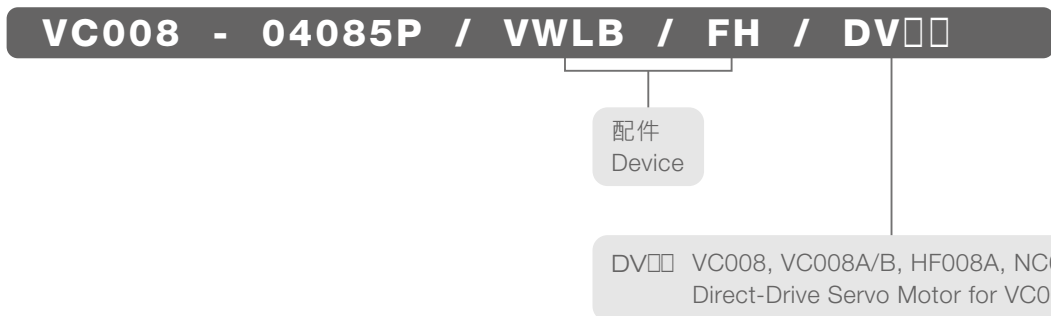

重慶



NC008

針送牛仔褲腰車

Needle-feed cylinder bed double chainstitch machine for jeans waistband



NC008 SERIES FEATURES

NC008

針送牛仔褲腰車

Needle-feed cylinder bed double chainstitch machine for jeans waistband



後拉輪能在高速車縫時讓送布均勻，線跡美觀

Rear puller allows stable material feeding and well-balanced seam.



可同步調整線跡長度與送布量的針送+下送送布機構

Needle feed and material feed can be adjusted synchronously.



可對應至16oz的丹寧布等重厚型布料

Work on heavy material like Denim, up to 16 oz.



最適合車縫牛仔褲腰，也可應用於牛仔褲的約克、捲邊縫、門襟車縫，上鬆緊帶



Designed for jeans waistband sewing, also can apply on jeans yoke seam, front, and elastic attaching.

配件 / DEVICE



HPR / 褲頭上帶滾邊車縫

適用於厚料工作褲·牛仔褲的上帶滾邊一次成型車縫
左右分開的下輪可用轉彎縫製·可依樣式選擇喇叭

HPR/WAISTBAND ATTACHING DEVICE

For tape binding on waistband of workwears pants, jeans...etc.
Refer to below table to find optional binders for desirable seams.



JD / 跳針裝置

避開褲腰車縫時不需下針的地方

Skip Stitch Device

Control freely to avoid stitches sewed on un-wanted working area.

選配喇叭 / OPTIONAL BINDER

成品尺寸 (Finished Size)	上下片直送 For Continuous Strips	上下片弧形 For Arched Type	側送喇叭 Side Feeding	前送喇叭 Front Feeding
1- 3/8" (36mm)	B516P	B518P	B519P	B530R
1- 1/2" (38mm)	B516Q	B518Q	B519Q	B530S
1- 5/8" (42mm)	B516R	B518R	B519R	B530T
1- 3/4" (45mm)	B516S	B518S	B519S	B530U
縫合樣式 Seam Type				

規格 / SPECIFICATION

NCO08							
NC008-02318	2	4	5/4" (31.75mm)	1.4-3.6	9	DXV57 #14-#25	4000
NC008-02381	2	4	3/2" (38.1mm)	1.4-3.6	9	DXV57 #14-#25	4000
NC008-0464-254	4	8	1/4-1-1/4" (6.4-25.4-6.4mm)	1.4-3.6	9	DXV57 #14-#25	4000
NC008-04254	4	8	1" (25.4mm)	1.4-3.6	9	DXV57 #14-#25	4000
NC008-0464-254/HPR	4	8	1/4-1-1/4" (6.4-25.4-6.4mm)	1.4-3.6	9	DXV57 #14-#25	4000
NC008-0464-222/HPR	4	8	1/4-7/8-1/4" (6.4-22.2-6.4mm)	1.4-3.6	9	DXV57 #14-#25	4000
NC008-06064	6	12	1/4" (6.4mm)	1.4-3.6	9	DXV57 #14-#25	4000

VC008 SERIES FEATURES

VC008

筒型多針縫紉機

**Multineedle cylinder bed double
chainstitch machine**



筒型機身設計，方便環型衣物縫紉

Cylinder machine frame design, easy sewing operation for circular cloth.



採用獨立勾針座，可變化不同的針位元組合，達到一機多用的功能（選配）

Using independent looper holder and can easily change different needle position, Multi-function machine design.(optional)



完全自動供油，勾針縱向運動機構，多針雙重鏈式縫

Automatic lubrication system, vertical looper mechanism, multineedle chainstitch mechanism.



按鈕式縫距調整模式，調整簡便快速

Stitch length adjustment by knob, easy and fast.



左側附一輔助設計，拉布穩定，出布更順暢，維護便利

Using one supportive puller on left side which can stabilize the pulling and sewing process.



適用於多種工序的縫紉，適合針織類高級衣物之裝飾車縫

Suitable for multi sewing process, high quality knit material and decorative sewing.

VC008A / B SERIES FEATURES



VC008A

筒型多針縫紉機(高貫穿力型)

Multineedle cylinder bed double chainstitch machine (High Penetration Power Type)



完全自動供油，勾針縱向運動機構，多針雙重鏈式縫

Automatic lubrication system, vertical looper mechanism, multineedle chainstitch mechanism.



採用獨立勾針座，可變化不同的針位元組合，達到一機多用的功能（選配）

Using independent looper holder and can easily change different needle position, Multi-function machine design.(optional)

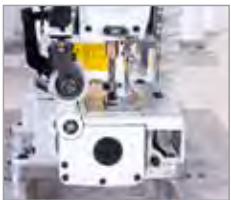

筒型機身設計，方便環型衣物縫紉

Cylinder machine frame design, easy sewing operation for circular cloth.



按鈕式縫距調整模式，調整簡便快速

Stitch length adjustment by knob, easy and fast.



左側附一輔助設計，拉布穩定，出布更順暢，維護便利

Using one supportive puller on left side which can stabilize the pulling and sewing process.



適用於多種工序的縫紉，適合針織類高級衣物之裝飾車縫

Suitable for multi sewing process, high quality knit material and decorative sewing.



新型軸承式滾輪，縫製時拉布與出布更順暢穩定

New bearing type rear puller handles the material with better stability.

VC008B

筒型多針縫紉機 (4~6針高速型)

Multineedle cylinder bed double chainstitch machine (4~6 needles High Speed Type)



使用皮帶傳動來驅動上下軸，實現高速穩定的縫製

New mechanism uses the belt to drive both upper and lower shaft, provides faster and more stable sewing experience.



平順且低震動，車縫薄料得心應手

High performance with thin material, less vibration and smoother movement.



新型軸承式滾輪，縫製時拉布與出布更順暢穩定

New bearing type rear puller handles the material with better stability.

Model	Specification	↕	↕	↔	每單位 (Unit)=3.2mm=1/8"																										Remark	
					1	2	3	4	5	6	7	8	9	10	11	12	13	14	15	16	17	18	19	20	21	22	23	24	25	26		
VC008- VC008A- VC008B-	04064P	4	8	1/4"(6.4mm)																												
	04085P			1/3"(8.5mm)																												
	04095P			3/8"(9.5mm)																												
	04106P			5/12"(10.6mm)																												
	04127P			1/2"(12.7mm)																												
	0448-191P			3/16-3/4-3/16" (4.8-19.1-4.8mm)																												
	0448-222P			3/16-7/8-3/16" (4.8-22.2-4.8mm)																												
	0448-254P			3/16-1-3/16" (4.8-25.4-4.8mm)																												
	0464-191P			1/4-3/4-1/4" (6.4-19.1-6.4mm)																												
	0464-127P			1/4-1/2-1/4" (6.4-12.7-6.4mm)																												
	0464-254P			1/4-1-1/4" (6.4-25.4-6.4mm)																												
	04A32-032P			(1/4-1/8-1/8-1/4")*3 (6.4-3.2-3.2-6.4mm)*3																												A
	04A64P			1/4"(6.4mm)																												A
	12A32-032P			(1/4-1/8-1/8-1/4")*3 (6.4-3.2-3.2-6.4mm)*3	6	12																										B
12A64P	1/4"(6.4mm)																													B		
VC008- VC008A-	12048P	12	24	3/16"(4.8mm)																												
	12064P			1/4"(6.4mm)																												
	12050P			1/5"(5.0mm)																												
	13032P			1/8"(3.2mm)																												
	13064P			1/4"(6.4mm)																											C	
	1332-032P			(1/4-1/8-1/8-1/4")*3 (6.4-3.2-3.2-6.4mm)*3																												
	17032P			1/8"(3.2mm)																											D	
	21032P			1/8"(3.2mm)																											E	
	23032P			1/8"(3.2mm)																												F

- A: 13 針規格組, 配 4 組針 / 勾針
- B: 13 針規格組, 配 6 組針 / 勾針
- C: 13 針規格組, 配 13 組針 / 勾針
- D: 17 針規格組, 配 17 組針 / 勾針
- E: 21 針規格組, 配 21 組針 / 勾針
- F: 23 針規格組, 配 23 組針 / 勾針

- A: 13-Needle gauge set with 4 sets of needle/ looper.
- B: 13-Needle gauge set with 6 sets of needle/ looper.
- C: 13-Needle gauge set with 13 sets of needle/ looper.
- D: 17-Needle gauge set with 17 sets of needle/ looper.
- E: 21-Needle gauge set with 21 sets of needle/ looper.
- F: 23-Needle gauge set with 23 sets of needle/ looper.

 mm	1.4-3.6	 mm	12	 Needle No.	UOX113GS #11~#14	 S.P.M. (Max)	4500
---	---------	--	----	--	---------------------	---	------



4針機型 4-Needle type

VC008-04XXX
VC008-04XXX-XXX



12針機型 12-Needle type

VC008-12XXX
VC008-12XXX-XXX
VC008-13XXX
VC008-13XXX-XXX
VC008-17XXX
VC008-21XXX
VC008-23XXX

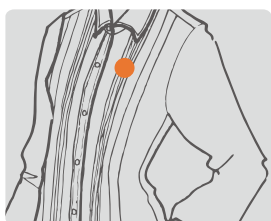









一般平縫

完全自動給油·勾針縱向運動機構·筒型車台·利於圓筒型衣物之縫紉·適用於一般高級衣物之裝飾車縫

GENERAL SEAMING



Cylinder bed automatic oiling, back and forth loopers driving mechanism, suitable for decorative sewing on high quality dress or tubular goods.

V2

Model	Specification				 mm	2.5-5	 mm	12	 Needle No.	UOX113GS #11~#14	 S.P.M. (Max)	4000	Remark																		
														每單位 (Unit)=3.2mm=1/8"																	
					1	2	3	4	5	6	7	8	9	10	11	12	13	14	15	16	17	18	19	20	21	22	23	24	25	26	
VC008-VC008B-	1132-064P	11	22	(1/8-1/4-1/8") (3.2-6.4-3.2mm)																											

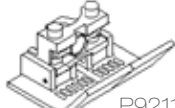

VC008-1132-064P

 VCL08S	細齒上拉輪 (鋼質)·薄牛仔 Fine teeth type upper puller (steel).light denim.	
 VCL16P	 VCL28	平輪組 (PU 材質) Flat type puller set (PU)
 P9211A-A	二段式壓腳 Two-piece type presser foot	



[三合一] 褲頭車縫

本機型適用鬆緊帶皺褶型、平坦型、薄牛仔·可以彈性組合出各種常用的4針針位組如1/4-1/4-1/4, 1/4-3/4-1/4...等

[3 in 1] Waist band sewing

This model is applicable to elastic band wrinkled type, flat type, light denim, which offers various 4-needle gauges by one set.
E.g.: 1/4-1/4-1/4, 1/4-3/4-1/4...etc.

選購配件 OPTIONAL DEVICE

VCE

								
				mm	mm	Needle No.	S.P.M. (Max)	
VC008- VC008B-	04064P/VCE	4	8	1/4"(6.4mm)	1.4-3.6	12	UOX113GS #11~#14	4000
	04085P/VCE	4	8	1/3"(8.5mm)	1.4-3.6	12	UOX113GS #11~#14	4000
	04095P/VCE	4	8	3/8"(9.5mm)	1.4-3.6	12	UOX113GS #11~#14	4000
	04106P/VCE	4	8	5/12"(10.6mm)	1.4-3.6	12	UOX113GS #11~#14	4000
	04127P/VCE	4	8	1/2"(12.7mm)	1.4-3.6	12	UOX113GS #11~#14	4000



VC008B-04064P/VCE

褲頭鬆緊帶車縫

用於運動褲或運動短褲等圓筒型衣褲腰部鬆緊帶的包縫。本機型可有兩種縫合的方式：

- (1)環型鬆緊帶布料折邊縫
- (2)拷克後上環型鬆緊帶包縫

ELASTIC INSERTING / ATTACHING





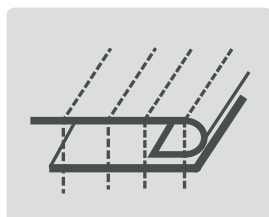
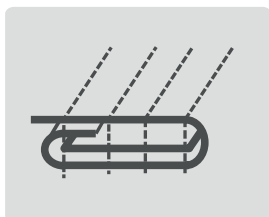

Inserting and attaching elastic on waistband of jogging suits, sportswears or shirts etc., two types of sewing functions are available :

1. To attach tubular seamless elastic waistband.
2. To cover sewing on elastic after overlock seaming.



選購配件 OPTIONAL DEVICE
VAD , VUT , RL



					 mm	 mm	 Needle No.	 S.P.M. (Max)
VC008- VC008A-	04064P/VWL	4	8	1/4"(6.4mm)	1.4-3.6	12	UOX113GS #11~#14	4000
	04085P/VWL	4	8	1/3"(8.5mm)	1.4-3.6	12	UOX113GS #11~#14	4000
	04095P/VWL	4	8	3/8"(9.5mm)	1.4-3.6	12	UOX113GS #11~#14	4000
	04106P/VWL	4	8	5/12"(10.6mm)	1.4-3.6	12	UOX113GS #11~#14	4000
	04127P/VWL	4	8	1/2"(12.7mm)	1.4-3.6	12	UOX113GS #11~#14	4000



VC008-04085P/VWL

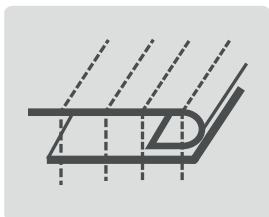

褲頭鬆緊帶車縫 (附B413喇叭)

鬆緊帶送帶滾輪裝置能依據機台之運轉速度送帶，可準確控制鬆緊帶長度與鬆緊度，操作簡便，適用於慢跑褲、運動褲、男女內褲等褲頭之鬆緊帶車縫

註：B413喇叭可用鬆緊帶尺寸為 38mm

ELASTIC ATTACHING (WITH FOLDER B413)

Elasticity and length feeding can be accurately controlled according to sewing speed of machine. Easy operation for elastic inserting and attaching on waistband of jogging pants, sportswears, briefs etc.

Remark : Elastic size 38mm for folder B413

選購配件	OPTIONAL DEVICE
	FH

							
				mm	mm	Needle No.	S.P.M. (Max)
VC008- VC008A-	04064P/VWLB	4	8	1/4"(6.4mm)	1.4-3.6	12	UOX113GS #11~#14 4000
	04085P/VWLB	4	8	1/3"(8.5mm)	1.4-3.6	12	UOX113GS #11~#14 4000
	04095P/VWLB	4	8	3/8"(9.5mm)	1.4-3.6	12	UOX113GS #11~#14 4000
	04106P/VWLB	4	8	5/12"(10.6mm)	1.4-3.6	12	UOX113GS #11~#14 4000
	04127P/VWLB	4	8	1/2"(12.7mm)	1.4-3.6	12	UOX113GS #11~#14 4000



VC008-04085P/VWLB

褲頭鬆緊帶車縫 (附B411喇叭及撐開滾輪組)

鬆緊帶送帶滾輪裝置能依據機台之運轉速度送帶，可準確控制鬆緊帶長度與鬆緊度，操作簡便，適用於慢跑褲、運動褲、男女內褲等褲頭之鬆緊帶車縫。

ELASTIC INSERTING (WITH FOLDER B411 AND EXTENDING ROLLER)

Elasticity and length feeding can be accurately controlled according to sewing speed of machine. Easy operation for elastic inserting and attaching on waistband of jogging pants, sportswears, briefs etc.

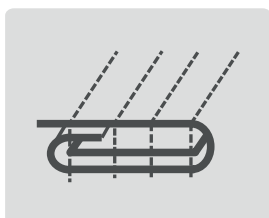

選購配件	OPTIONAL DEVICE
	FH

喇叭尺寸 Folder Size	成品尺寸 Finished Size	鬆緊帶尺寸 Elastic Tape Size	適用機型 Applicable Model
B411	33 mm	31 mm	04095
B411P	30 mm	28 mm	04085
B411Q	42 mm	40 mm	04127
B411R	25 mm	23 mm	04064
B411S	36 mm	34 mm	04106

					 mm	 mm	Needle No.	 S.P.M. (Max)
VC008- VC008A-	04064P/VWLC	4	8	1/4"(6.4mm)	1.4-3.6	12	UOX113GS #11~#14	4000
	04085P/VWLC	4	8	1/3"(8.5mm)	1.4-3.6	12	UOX113GS #11~#14	4000
	04095P/VWLC	4	8	3/8"(9.5mm)	1.4-3.6	12	UOX113GS #11~#14	4000
	04106P/VWLC	4	8	5/12"(10.6mm)	1.4-3.6	12	UOX113GS #11~#14	4000
	04127P/VWLC	4	8	1/2"(12.7mm)	1.4-3.6	12	UOX113GS #11~#14	4000
	12048P/VWLC	12	24	3/16"(4.8mm)	1.4-3.6	12	UOX113GS #11~#14	4000
	12064P/VWLC	12	24	1/4"(6.4mm)	1.4-3.6	12	UOX113GS #11~#14	4000



VC008-04085P/VWLC

褲頭鬆緊帶車縫 (附VCE導片)

鬆緊帶送帶滾輪裝置能依據機台之運轉速度送帶，可準確控制鬆緊帶長度與鬆緊度，操作簡便，適用於慢跑褲、運動褲、男女內褲等褲頭之鬆緊帶車縫

ELASTIC INSERTING /ATTACHING (WITH VCE FABRIC GUIDE)





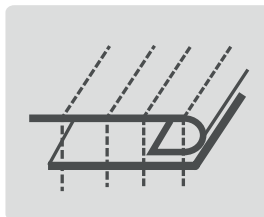
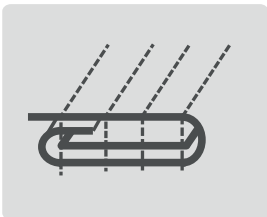

Elasticity and length feeding can be accurately controlled according to sewing speed of machine. Easy operation for elastic inserting and attaching on waistband of jogging pants, sportswears, briefs etc.



選購配件 OPTIONAL DEVICE
FH



V7

								
VC008- VC008A-	02064P/VMR	2	4	1/4"(6.4mm)	1.4-3.6	12	UOX113GS #11~#14	1000



VC008-02064P/VMR

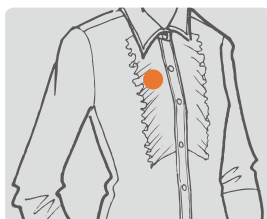

折景車縫(規則波浪)





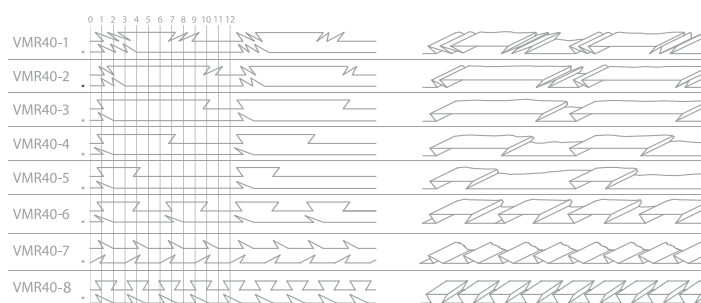

由8種花盤變化·可縫製8種不同花樣之折景·適用於高級衣飾·窗簾·床罩等寢具的裝飾縫及桌巾或室內裝飾品之打折縫

RUFFLING (REGULAR WAVY TUCK)

For ruffling sewing on blouses, curtains, bed sheets, tablecloths or decorating cloth etc., 6 different kinds of cam variations available to obtain various ruffling designs.



V8

								
VC008- VC008B-	06048P/VPL	6	12	3/16"(4.8mm)	1.4-3.6	12	UOX113GS #11~#14	4000
	06064P/VPL	6	12	1/4"(6.4mm)	1.4-3.6	12	UOX113GS #11~#14	4000



VC008B-06064P/VPL

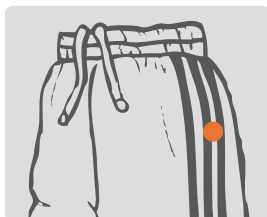

上帶車縫

適用於裝飾條帶·運動衣褲等車縫·效率高·品質穩定







TAPE ATTACHING

Suitable for attaching ornament tape on sportswears. For high efficiency and perfect quality sewing.

選購配件 OPTIONAL DEVICE
LSA

若需要更高階機型, 請參考 ASV-ATS100 (P.16)
For advanced model, please refer to ASV-ATS100 (P.16)



								
		12	24	3/16"(4.8mm)	1.4-3.6	12	UOX113GS #11~#14	4000
VC008- VC008A-	12048P/VPQ	12	24	3/16"(4.8mm)	1.4-3.6	12	UOX113GS #11~#14	4000
	12064P/VPQ	12	24	1/4"(6.4mm)	1.4-3.6	12	UOX113GS #11~#14	4000



VC008-12064P/VPQ

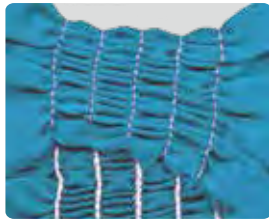
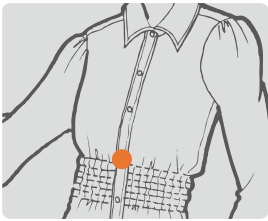

鬆緊帶抽皺縫裝置







適用於女皺褶連身衣裙等腰邊鬆緊線皺褶，如女用襯衫，游泳衣，枕頭套，兒童衫等均能車縫順暢

註：勾針底線宜用彈性線

ELASTIC THREAD SHIRRING SEWING

Suitable for sewing ornamental shirring with elastic thread on women's blouses, swimsuits, dresses, pillowcases, and children's shirts etc.

Remark : Suggested to use elastic thread for lower looper

								
VC008- VC008A-	12048P/VPQ-K	12	24	3/16"(4.8mm)	1.4-3.6	12	UOX113GS #11~#14	4000
	12064P/VPQ-K	12	24	1/4"(6.4mm)	1.4-3.6	12	UOX113GS #11~#14	4000



VC008-12048P/VPQ-K

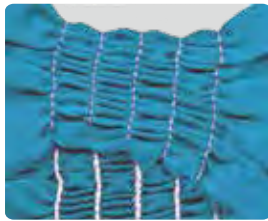
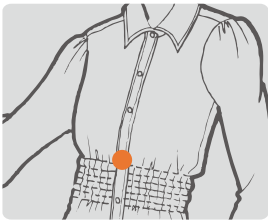

鬆緊帶抽皺縫裝置

適用於女皺褶連身衣裙等腰邊鬆緊線皺褶，如女用襯衫，游泳衣，枕頭套，兒童衫等均能車縫順暢

註：

1. 勾針底線宜用彈性線
2. 增加VWL組可穩定彈性線的鬆緊度讓車縫更平順美觀，不跳針
3. 將彈性線安裝於桌板下，讓彈性線車縫更順暢
4. 本機為多功能車，可調為VWL·VPQ或一般車使用

ELASTIC THREAD SHIRRING SEWING





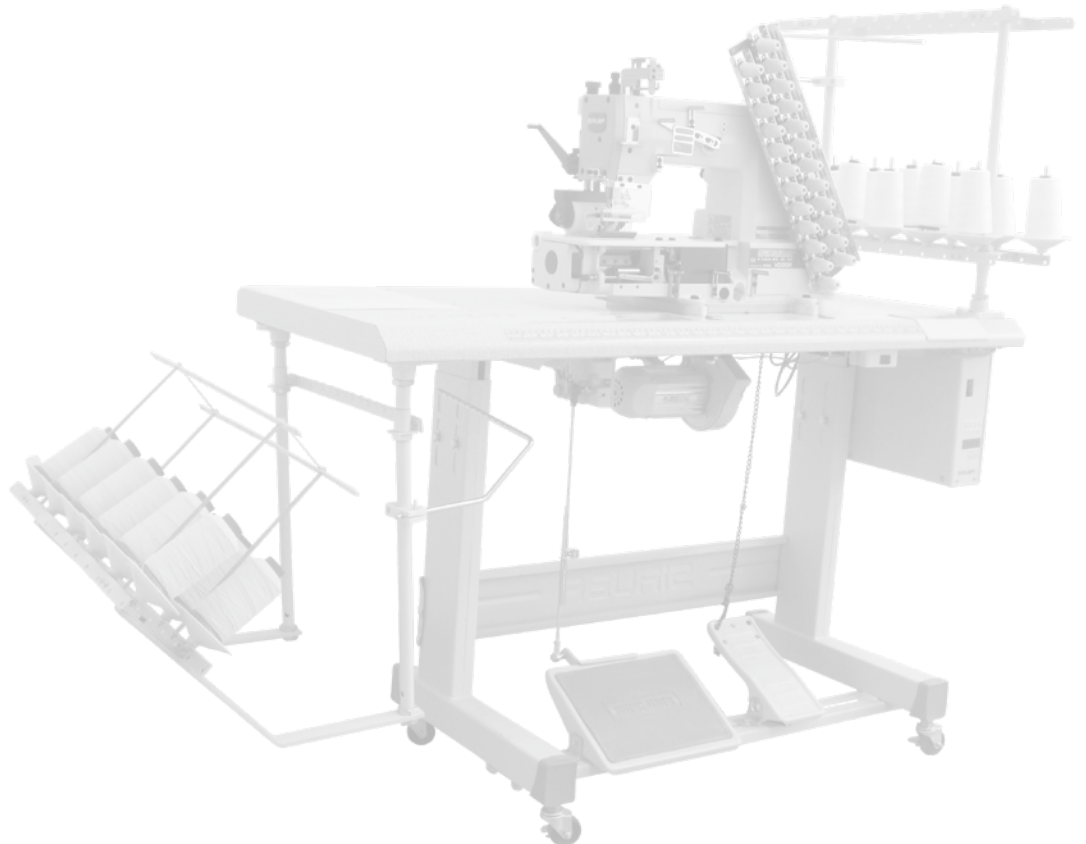

Suitable for sewing ornamental shirring with elastic thread on women's blouses, swimsuits, dresses, pillowcases, and children's shirts etc.

Remark :

1. Suggested to use elastic thread for lower looper.
2. The added VWL set will further stabilize the tension of elastic thread and make sewing process more smoothly, also can avoid stitch skipping.
3. Holds the elastic thread under the table to make sewing process more smoothly.
4. This is a multifunctional machine, can easily adjust to VWL, VPQ, or standard machine.



V11

					 mm	 mm	Needle No.	 S.P.M. (Max)
VC008-VC008A-	12048P/VPS	12	12	3/16"(4.8mm)	1.4-3.6	12	DV-K25 #18~21	4000
	12064P/VPS	12	12	1/4"(6.4mm)	1.4-3.6	12	DV-K25 #18~21	4000



VC008-12064P/VPS

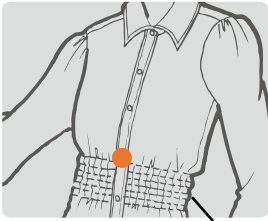

鬆緊帶抽皺縫裝置

適用於女皺褶連身衣裙等腰邊鬆緊線皺褶，如女用襯衫、游泳衣、枕頭套、兒童衫等均能車縫順暢







註:針線用彈性線，以勾針為勾線功能不穿線，為101車縫式樣

ELASTIC THREAD SHIRRING SEWING

Suitable for sewing ornamental shirring with elastic thread on women's blouses, swimsuits, dresses, pillowcases, and children's shirts etc.

Remark: Needle uses elastic thread and looper without thread. It's 101 sewing type.

V12

					 mm	 mm	Needle No.	 S.P.M. (Max)
VC008-VC008A-	12048P/VPT	12	24	3/16"(4.8mm)	1.4-3.6	12	UOX113GS #11~#14	2500
	12064P/VPT	12	24	1/4"(6.4mm)	1.4-3.6	12	UOX113GS #11~#14	2500



VC008-12064P/VPT

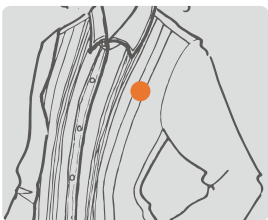

褶布車縫







可自由多種調整導邊器之組合，車縫成各種不同式樣之右傾或左傾褶縫，如襯衫、連衣裙、兒童衫等細條打褶用

PIN TUCKING

Suitable for pin-tuck sewing on men's, women's, and children's shirt, dress, etc. Attachment is freely adjustable in various sewing style of left or right side folding.



V13

								
VC008- VC008B-	0448-254P/VSF	4	8	3/16-1-3/16" (4.8-25.4-4.8mm)	1.4-3.6	12	UOX113GS #11~#14	4000
	0464-191P/VSF	4	8	1/4-3/4-1/4" (6.4-19.1-6.4mm)	1.4-3.6	12	UOX113GS #11~#14	4000
	0464-254P/VSF	4	8	1/4-1-1/4" (6.4-25.4-6.4mm)	1.4-3.6	12	UOX113GS #11~#14	4000



VC008-0464-254P/VSF

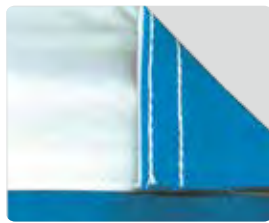
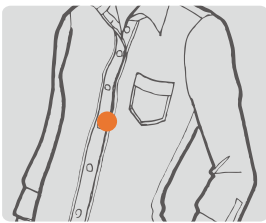

襯衫門襟車縫







適宜各種四針或二針之襯衫門襟車縫，由於加裝喇叭使在一個工序即可完成車縫，另可選擇不同的喇叭做不同之車縫樣式

SHIRT-FRONTING ATTACHING

With a special folder to sew on 2 or 4 needled shirt fronting, complete in one simple sewing operation. Also available are the various folders for different sewing style.

選購配件	OPTIONAL DEVICE
LSA	

V14

								
VC008- VC008A-	12048P/VSM	12	24	3/16"(4.8mm)	1.4-3.6	12	DVX57 #18~#21	2000
	12064P/VSM	12	24	1/4"(6.4mm)	1.4-3.6	12	DVX57 #18~#21	2000



VC008-12048P/VSM

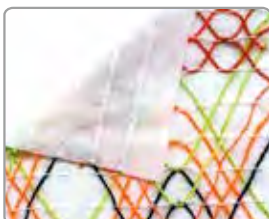
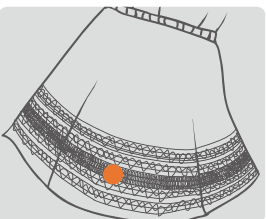







花飾縫

由十六個花盤變化，利用針線之搭配，可縫製數十種不同花樣，適用於高級衣飾、窗簾、床單等寢具的裝飾縫及桌巾或室內裝飾品之花飾縫

DECORATIVE SEWING

To use sixteen different cams of variation for different sewing, suitable for decorative sewing on high quality dresses, curtains, bed sheets and tablecloths.

V15

								
					mm	mm	Needle No.	S.P.M. (Max)
VC008- VC008A-	12048P/VSQ	12	12	3/16"(4.8mm)	1.4-3.6	12	DV-K25 #18	2000
	12064P/VSQ	12	12	1/4"(6.4mm)	1.4-3.6	12	DV-K25 #18	2000



VC008-12048P/VSQ

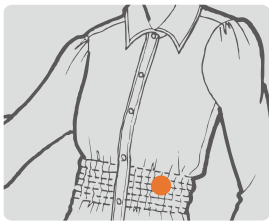







鬆緊抽皺花飾縫

由16種花盤變化，利用針線之搭配，可縫製數十種不同花樣，適用於高級衣飾、窗簾、床罩等寢具的裝飾縫及桌巾或室內裝飾品之花飾縫

DECORATIVE SEWING WITH ELASTIC THREAD SHIRRING

To use sixteen different cams of variation for different sewing, suitable for decorative sewing on high quality dresses, curtains, bed sheets, tablecloths.

V16

								
					mm	mm	Needle No.	S.P.M. (Max)
VC008- VC008A-	12048P/VSC	12	36	3/16"(4.8mm)	1.4-3.6	12	UOX113GS #11~#14	2500
	12064P/VSC	12	36	1/4"(6.4mm)	1.4-3.6	12	UOX113GS #11~#14	2500



VC008-12064P/VSC

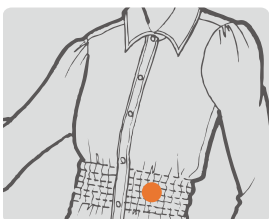

鬆緊帶抽皺縫裝置

彈性線直送不打線圈，由針線與勾針線上下包覆，車縫成品效果較VPQ薄，且皺褶可拉伸至完全平坦

ELASTIC THREAD SHIRRING SEWING

Elastic thread is straight, not looped, which is fixed by needle thread and looper thread. The finish is thinner than VPQ and the shirring becomes flat as it is pulled extensively.



		Needle	Foot	Thread	Stitch Width	Stitch Length	Needle No.	S.P.M. (Max)
VC008- VC008A-	12048P/VSSM	12	24	3/16"(4.8mm)	1.4-3.6	12	DVX57 #18~#21	2000
	12064P/VSSM	12	24	1/4"(6.4mm)	1.4-3.6	12	DVX57 #18~#21	2000



VC008-12048P/VSSM

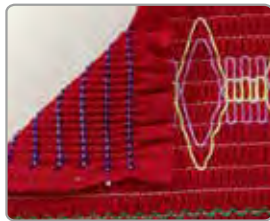
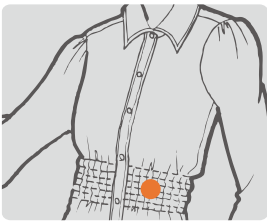

花飾縫

由十六個花盤變化，利用針線之搭配，可縫製數十種不同花樣，適用於高級衣飾、窗簾、床罩等寢具的裝飾縫及桌巾或室內裝飾品之花飾縫

DECORATIVE SEWING



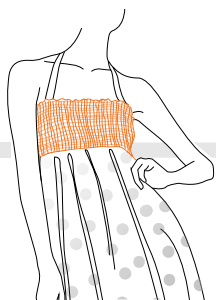



To use sixteen different cams of variation for different sewing, suitable for decorative sewing on high quality dresses, curtains, bed sheets and tablecloths.



VC008 SERIES (OVER 25 NEEDLES)

Multineedle cylinder bed double chainstitch machine

V18

				 mm	 Needle No.	 S.P.M. (Max)
VC008-25032P	25	50	1/8"	12	DVX57#14-#16	1500
VC008-25064P	25	50	1/4"	12	DVX57#14-#16	1500
VC008-33048P	33	66	3/16"	12	DVX57#14-#16	1500
VC008-38064P	38	76	1/4"	12	DVX57#14-#16	1500
VC008-50032P	50	100	1/8"	12	DVX57#14-#16	1500



VC008-25/33P

多針雙線鏈式縫紉車

針對於襯衫、女士禮服的平縫，最適合於需要的寬幅褶縫服裝品的縫製

DOUBLE CHAINSTITCH MACHINE

It is suitable for sewing wide stitch or wider interval stitch on skirt, blouse, negligee, etc.



VC008-25064P 1/4"

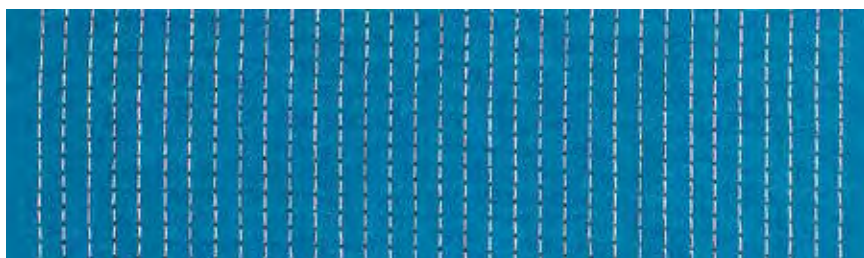

VC008-33048P 3/16"



	Needle No.	Foot	Stitch Width	Stitch Length	Needle No.	S.P.M. (Max)
VC008-25064PQ2	25	50	1/4"	12	DVX113#11-#14	1500
VC008-33048PQ2	33	66	3/16"	12	DVX113#11-#14	1500
VC008-38064PQ2/A38	38	76	1/4"	10	DVX57#12-#14	900
VC008-50048PQ2/A50	50	100	3/16"	10	DVX57#12-#14	900



VC008-PQ2

彈性線縮褶車

適用於女士各種衣裙腰圍鬆緊打褶。彈性均勻，線跡完美

SHIRRING STITCH MACHINE

It is suitable for shirring of all kinds of women's dresses on waist. Perfect stitches with uniform elasticity.







VC008-25064PQ2 1/4"



VC008-33048PQ2 3/16"

V20

					mm	Needle No.	 S.P.M. (Max)
VC008-25064PQ3	25	75	1/4"	12		DVX57#14-#16	1500
VC008-33048PQ3	33	99	3/16"	12		DVX57#14-#16	1500
VC008-38064PQ3/A38	38	114	1/4"	10		DVX57#12-#14	900
VC008-38048PQ3/A50	50	150	3/16"	10		DVX57#12-#14	900



VC008-PQ3

彈性線縮褶車

適用於女裝 (上衣 · 裙子) 的腰圍、胸圍的鬆緊打褶。彈性柔和，線跡完美

SHIRRING STITCH MACHINE

It is suitable for shirring of women's clothes (including dress and shirts) on waist and bust. Beautiful and flexible stitches.

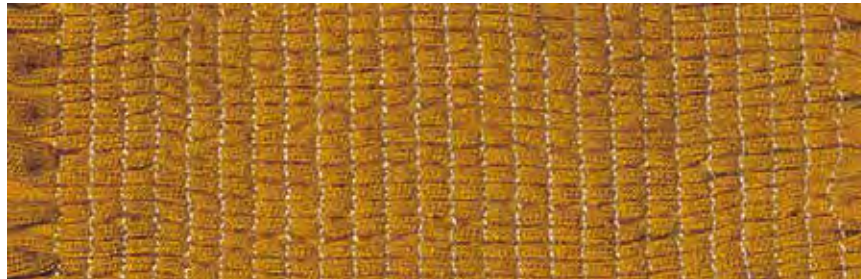

VC008-25064PQ3 1/4"



VC008-33048PQ3 3/16"

						
				mm	Needle No.	S.P.M. (Max)

VC008-16048PQ3M	16	64	3/16"	12	DVX57#14-#16	1500
VC008-25064PQ3M	25	100	1/4"	12	DVX57#14-#16	1500
VC008-33048PQ3M	33	132	3/16"	12	DVX57#14-#16	1500
VC008-38064PQ3M/A38	38	152	1/4"	10	DVX57#12-#14	900
VC008-50048PQ3M/A50	50	200	3/16"	10	DVX57#12-#14	900



VC008-PQ3M

彈性線縮褶打攬車

適用於女裝（上衣・裙子）的腰圍・胸圍的鬆緊打褶・打攬。可以選擇不同的裝飾線圖案，彈性柔和，線跡柔美

SHIRRING SMOCKING STITCH MACHINE

It is suitable for shirring and smocking of women's clothes (including dresses and shirts) on waist and bust. Various Ornamental stitch patterns can be chosen. Beautiful and flexible stitches.

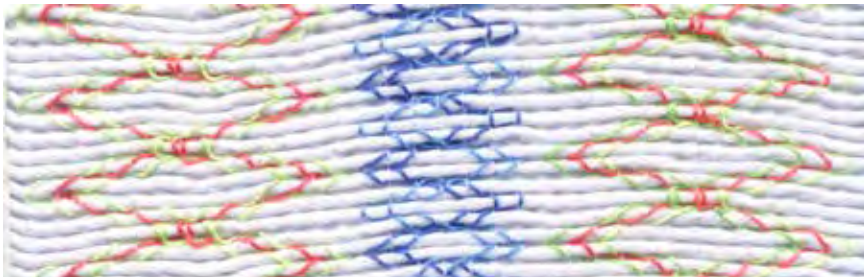



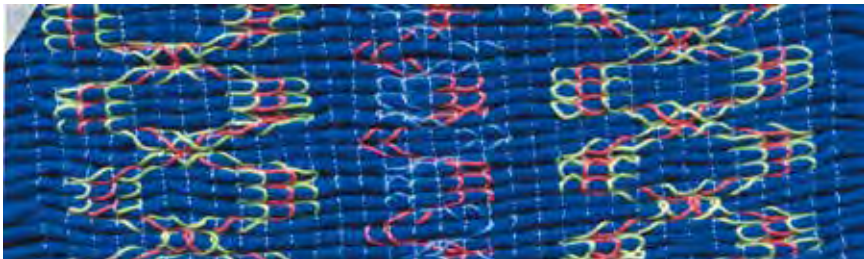

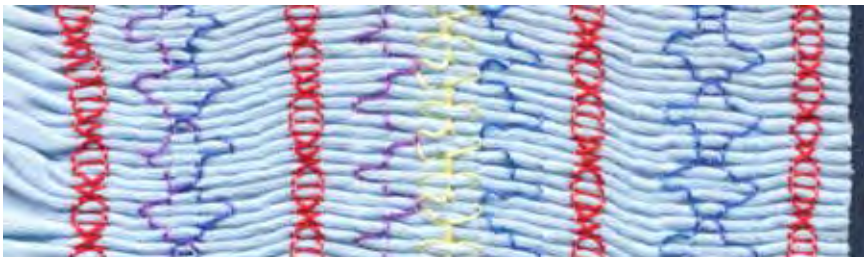

VC008-33048PQ3M 3/16"



VC008-33048PQ3M 3/16"



VC008-25064PQ3M 1/4"

						
				mm	Needle No.	S.P.M. (Max)
VC008-25064PQS	25	25	1/4"	12	DVX57#14-#16	1500
VC008-33048PQS	33	33	3/16"	12	DVX57#14-#16	1500
VC008-38064PQS/A38	38	38	1/4"	10	DVX57#12-#14	900
VC008-50048PQS/A50	50	50	3/16"	10	DVX57#12-#14	900



VC008-PQS

彈性線(無底線)多針

單線鏈式多針車，適用於女士裙子腰圍鬆緊帶打褶，也適用於童裝打褶。鬆緊均勻線跡完美

SHIRRING STITCH MACHINE (NO LOWER THREAD)

Single thread, multi-needle machine. It is suitable for sewing ornamental shirring with elastic thread on women's dresses and children's clothes. Perfect stitches with uniform elasticity.



VC008-25064PQS 1/4"



VC008-33048PQS 3/16"

VC008-25064PQSM	25	50	1/4"	12	DVX57#14-#18	1500
VC008-33048PQSM	33	66	3/16"	12	DVX57#14-#18	1500
VC008-38064PQSM/A38	38	76	1/4"	10	DVX57#12-#14	900
VC008-50048PQSM/A50	50	100	3/16"	10	DVX57#12-#14	900



VC008-PQSM

(無底線)打攬

PQSM 是無底線打攬縫紉機，因面線是彈性線單線連縫，所以能適用於薄針織品，及各種薄布物料，至於圖案，就可以利用備用各種各樣花盤，再與彈性線搭配起來，可以創造出為數不少令人吸引的圖案

(NO LOWER THREAD) SMOCKING MACHINE

PQSM is the smocking stitch without lower thread machine. Because the upper stitch is sewing by elastic thread, it is suitable for thin materials or light knitwear. By combining various cams with ornamental thread, it is practicable to make varied attractive patterns.



VC008-25064PQSM 1/4"

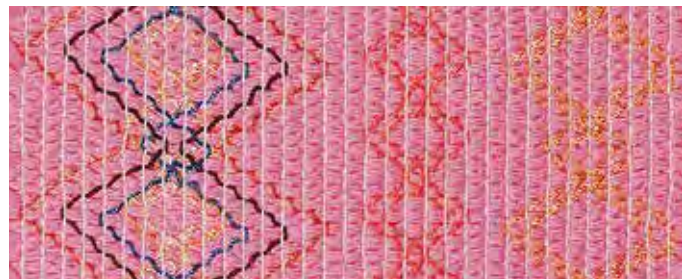



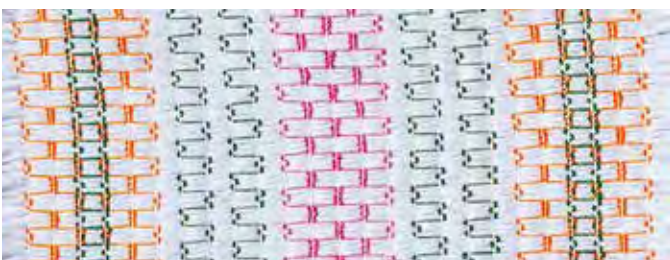



VC008-33048PQSM 3/16"



VC008-25064PQSM 1/4"



VC008-25064PQSM 1/4"

						
VC008-25064PSM	25	75	1/4"	12	DVX57#14-#16	1500
VC008-33048PSM	33	99	3/16"	12	DVX57#14-#16	1500
VC008-33064PSM/A38	38	114	1/4"	10	DVX57#12-#14	900
VC008-50048PSM/A50	50	150	3/16"	10	DVX57#12-#14	900



VC008-PSM

裝飾線打攪車

適用於各種襯衫·衣裙·童裝的裝飾縫。也適用於各種床上用品的裝飾縫，可選配不同的花盤·縫出想要的圖案

加裝附件：打攪器·各種型號花盤

ORNAMENTAL THREAD SMOCKING MACHINE

It is suitable for ornamental stitches on women's & children's wear, skirts, fashions, bedclothes, etc..Stitching patterns can be chosen by varied cams.

Attachment : Smocking device and varies cams



VC008-33048PSM 3/16"



VC008-33048PSM 3/16"

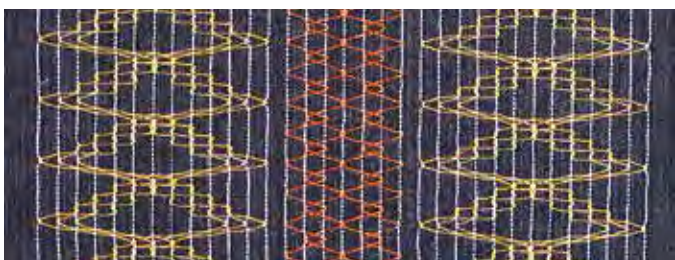

VC008-33048PSM 3/16"



VC008-25048PSM 3/16"

VC008-16048PSSM	16	48	3/16"	12	DVX57#14-#16	1500
VC008-25064PSSM	25	75	1/4"	12	DVX57#14-#16	1500
VC008-33048PSSM	33	99	3/16"	12	DVX57#14-#16	1500
VC008-38064PSSM/A38	38	114	1/4"	10	DVX57#12-#14	900
VC008-50048PSSM/A50	50	150	3/16"	10	DVX57#12-#14	900



VC008-PSSM

彈性線縮褶打攬車

適用於女裙打褶·連衣裙等腰邊緊鬆打褶。也適用於各種童裝·床上用品的裝飾縫。鬆緊均勻·線跡完美。可選配不同的花盤縫出想要的圖案

SHIRRING SMOCKING STITCH MACHINE

Suitable for stitching smocking with shirring on waist of skirt, fashion, children's clothes, bedclothes, etc.. Stitching patterns can be chosen by various cams.

加裝附件：大小前托輪、各種型號花盤。
Attachment : pullers and various cams.



VC008-33048PSSM 3/16"

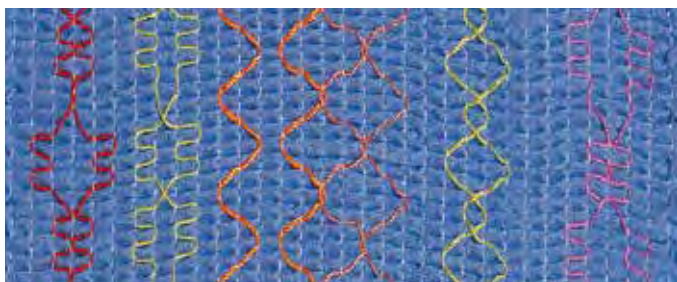







VC008-33048PSSM 3/16"



VC008-25064PSSM 1/4"



VC008-33048PSSM 3/16"

					 Needle No.	 S.P.M. (Max)
VC008-25064PTV	25	50	1/4"	12	DVX57#11-#14	1500
VC008-33048PTV	33	66	3/16 "	12	DVX57#11-#14	1500



VC008-PTV

襯衫打褶車

此台PTV機器可以對服飾·床上用品及各種裝飾用品打褶·在針位以內的打褶寬度可以任意挑選

SHIRT PINTUCKINGS STITCH MACHINE

PTV machine is suitable for tucking on all kinds of products. Any size of tucking within the width of needle gauge can be chosen.



VC008-25064PTV 1/2"



VC008-33048PTV 3/8"

V27



	16	32	3/16"	12	DVX57#14-#16	1500
VC008-16048PQT	16	32	3/16"	12	DVX57#14-#16	1500
VC008-25064PQT	25	50	1/4"	12	DVX57#14-#16	1500
VC008-33048PQT	33	66	3/16"	12	DVX57#14-#16	1500



VC008-PQT

彈性線車

適用於女士各種衣裙等腰圍胸圍的打褶。鬆緊均勻，線跡完美

SHIRRING STITCH MACHINE

It is suitable for shirring of women's clothes (including dresses and shirts) on waist and bust. Beautiful and flexible stitches.



VC008-33048PQT 3/16"



VC008-25064PQT 1/4"



VC008-33048PQT 3/16"

						
--	---	---	---	--	---	---

VC008-25064PQTM	25	75	1/4"	12	DVX57#14-#16	1500
VC008-33048PQTM	33	99	3/16"	12	DVX57#14-#16	1500



VC008-PQTM

打攬車

適用於女裝 (上衣·裙子)的腰圍·胸圍的鬆緊打褶·打攬。可以選擇不同的裝飾線條圖案·彈性柔和·線跡柔美

SMOCKING MACHINE

It is suitable for shirring and smocking of women's clothes (including dresses and shirts) on waist and bust. Various Ornamental stitch patterns can be chosen. Beautiful and flexible stitches.

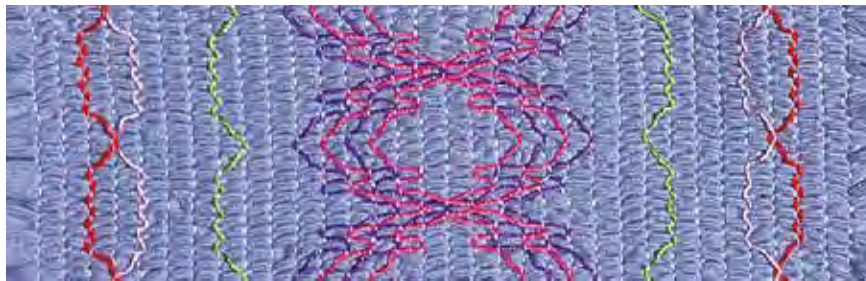

VC008-33048PQTM 3/16"

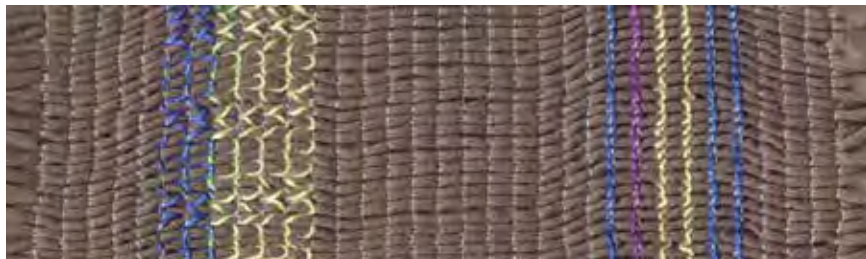

VC008-33048PQTM 3/16"



VC008-25064PQTM 1/4"

Sewing Samples

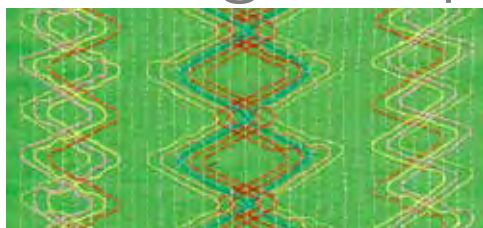

花盤型號 /CAM:602L

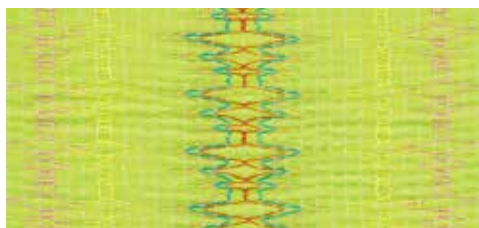

花盤型號 /CAM:471L

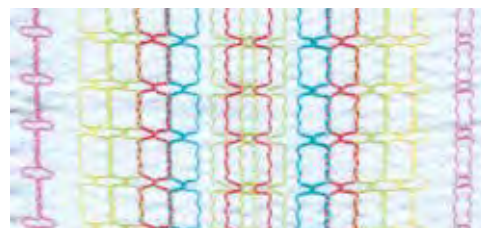

花盤型號 /CAM:211L



花盤型號 /CAM:392L

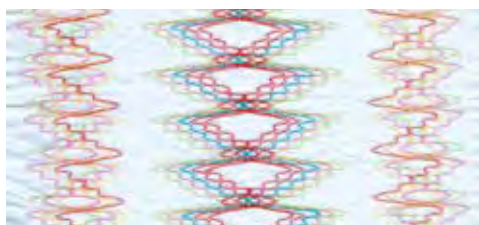

花盤型號 /CAM:674L



花盤型號 /CAM:482L

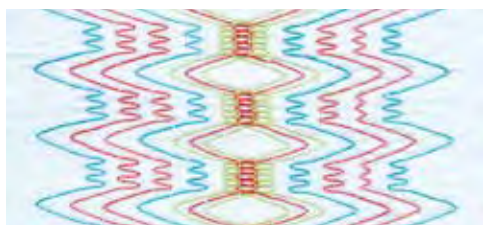

花盤型號 /CAM:545L



花盤型號 /CAM:214L

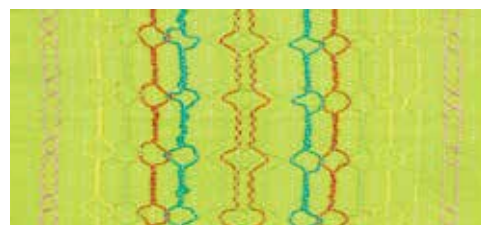

花盤型號 /CAM:231

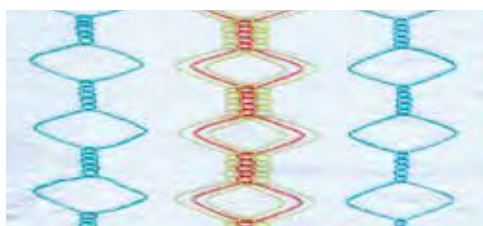

花盤型號 /CAM:545L



花盤型號 /CAM:202



花盤型號 /CAM:671L



花盤型號 /CAM:545L

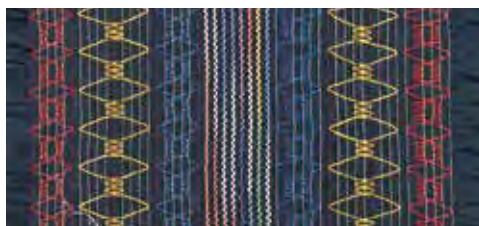

花盤型號 /CAM:545L.101



花盤型號 /CAM:202.101

Sewing Samples



花盤型號 /CAM:674L.302R



花盤型號 /CAM:381L.202



花盤型號 /CAM:371L.101



花盤型號 /CAM:592L.101



花盤型號 /CAM:571L.202



花盤型號 /CAM:302L.202



花盤型號 /CAM:545L.202

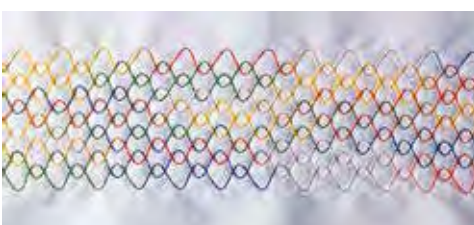

花盤型號 /CAM:302L

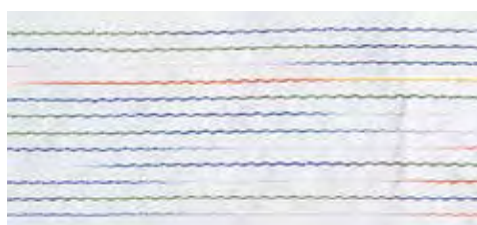

花盤型號 /CAM:101



花盤型號 /CAM:674L.371R



花盤型號 /CAM:545L.302R

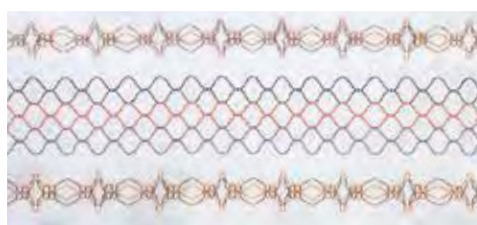

花盤型號 /CAM:381L.302R



花盤型號 /CAM:571.202



花盤型號 /CAM:674L.371R



花盤型號 /CAM:602L.381R

機型 Model	品名 Name	備註 Remark
VC008-25/33P	25/33 針 · 雙線鏈式縫紉車 25/33 needle, double chainstitch machine	後拉滾輪 · 一般縫紉 Rear puller, general seaming.
VC008-PQ2(1/4)	25/33/38/50 針 · 彈性線縮褶車 25/33/38/50 needle, shirring stitch machine	上線普通 · 下線彈性線 · 加前輪 The upper thread is the general thread, the lower thread is the elastic thread, the front wheel is attached.
VC008-PQ3(1/4)	25/33/38/50 針 · 彈性線縮褶車 25/33/38/50 needle, shirring stitch machine	上線普通 · 下線普通 · 布的下面包彈性線 The upper thread is the general thread, the lower thread is the general thread, the elastic thread is underneath the cloth.
VC008-PQ3M(1/4)	16/25/33/38/50 針 · 彈性線縮褶打攪車 16/25/33/38/50 needle, shirring smocking stitch machine	上線普通 · 下線普通 · 布的下面包彈性線 · 打攪 The upper thread is the general thread, the lower thread is the general thread, the elastic is underneath the cloth, smocking.
VC008-PQS(1/4)	25/33/38/50 針 · 彈性線 (無底線) 多針車 25/33/38/50 needle, no lower thread shirring stitch machine	無底線 No lower thread.
VC008-PQSM(1/4)	25/33/38/50 針 · 無底線打攪車 25/33/38/50 needle, no lower thread smocking machine	無底線 · 打攪 No lower thread, smocking.
VC008-PSM/PTV(1/4)	25/333 針 · 打攪打褶綜合車 25/33 needle, smocking pintucking machine	打折 (25 條) 可打折寬度 1-2mm Pintucking (25 lines), the width of pintucking is 1~2mm.
VC008-PSM/PL(1/4)	25/33/38/50 針 · 打攪貼條綜合車 25/33/38/50 needle, smocking tape-attaching machine	上下普通線打攪 · 同時加運動貼條 The upper thread is the general thread, the lower thread is general thread, smocking the tape is attached simultaneously.
VC008-PSM (1/4)	25/33/38/50 針 · 裝飾線打攪車 25/33/38/50 needle, ornamental thread smocking machine	上線普通 · 下線普通 · 打攪 The upper thread is the general thread, the lower thread is the general thread, smocking.
VC008-PSSM(1/4)	16/25/33 針 · 彈性線縮褶打攪車 16/25/33 needle, shirring smocking stitch machine	上線普通 · 下線彈性線 · 打攪 · 加前輪 The upper thread is the general thread, the lower thread is the elastic thread, smocking, the front wheel is attached.
VC008-PTV(1/4)	25/33 針 · 襯衫打褶車 25/33 needle, shirts pintucking machine	打折 (25 條) 可打折寬度 1-2mm Pintucking (25 lines), the width of pintucking is 1~2mm.
VC008-PQT	25/33 針 · 彈性線車 25/33 needle, shirring stitch machine	上線普通 · 無底線 · 布的下面包彈性線 The upper thread is the general thread, no lower thread, the elastic underneath the cloth.
VC008-PQTM	25/33 針 · 打攪車 25/33 needle, smocking stitch machine	上線普通 · 無底線 · 布的下面包彈性線打攪 The upper thread is the general thread, no lower thread, the elastic underneath the cloth, smocking.

DEVICE

機型 Model	上線 Upper (Needle) Thread	下線 Lower (Looper) Thread	布下面包彈性線 Extra Elastic Thread Under Fabric	前輪 Front Puller	打攪裝置 Smocking Device	備註 Remark
P	普通 Cotton	普通 Cotton	--	--	--	
PQ2	普通 Cotton	彈性線 Elastic	--	有 Yes	--	
PQ2R	普通 Cotton	--	布上面 Upper Textile	有 Yes	有 Yes	
PQS	彈性線 Elastic	--	--	選配 Optional	--	粗彈性線 Thick Elastic Thread
PQSM	彈性線 Elastic	--	--	選配 Optional	有 Yes	
PSM	普通 Cotton	普通 Cotton	--	--	有 Yes	
PSSM	普通 Cotton	彈性線 Elastic	--	有 Yes	有 Yes	
PQ3	普通 Cotton	普通 Cotton	有 Yes	有 Yes	--	
PQ3M	普通 Cotton	普通 Cotton	有 Yes	有 Yes	有 Yes	
PTV	普通 Cotton	普通 Cotton	--	--	--	打褶裝置 With Pin-tucking Device
PSM+PTV	普通 Cotton	普通 Cotton	--	--	有 Yes	打褶裝置 With Pin-tucking Device
PQT	普通 Cotton	--	有 Yes	有 Yes	--	
PQTM	普通 Cotton	--	有 Yes	有 Yes	有 Yes	

打攪機花盤圖樣

PATTERN OF CAMS

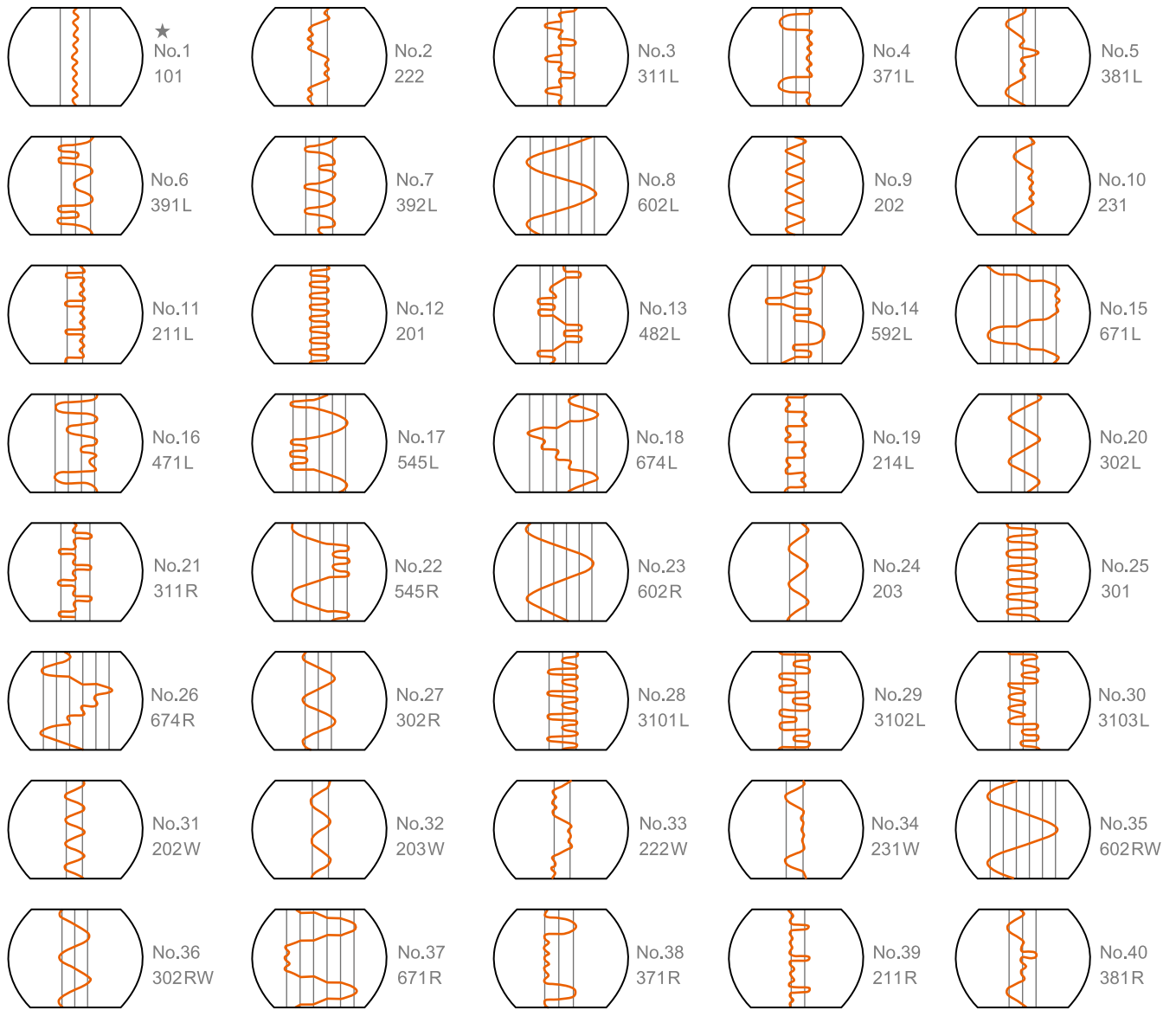

在更換使用花盤時，花盤編號後帶“L”的為控制下面兩層打攪條，應安裝在靠機頭的裡面；花盤編號後帶“R”的為控制上面兩層打攪條，應安裝在外面，切記不可倒裝，否則編不出花型。另有花盤編號後帶“W”的和“101”“202”“203”等花盤為裡外皆可安裝的。

When replacing the face plate, if the code of the face plate added on “L” means it controls the under tow—layered smocking tape, so it should be installed inside and near the machine head. If the code of the face plate added on “R” means it controls the upper two-layered smocking tape, so it should be installed outside. Do not install two kinds of the face plates upside down, or it can't make the patterns. Besides, there are the codes of the face plate added on “W”, “101”, “202”, and “203”, which means they can be installed both inside and outside.

HF008A SERIES FEATURES

HF008A

平台型牛仔用二重環縫紉機

Flat bed double chainstitch machine
for jeans



精心設計之供油系統及零配件精度加工，延長機器使用壽命

Using unique design of lubrication system and attachments to extend the machine lifetime.



按鈕式縫距調節，可適合多品種生產

Stitch length adjustment by knob, suitable for all different kinds of materials.



上、下滾輪之雙重配合使出布更順暢

Upper and lower puller design to make sewing process more stable.

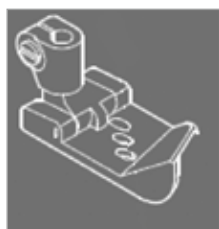

HF008A-03XXX-XXX

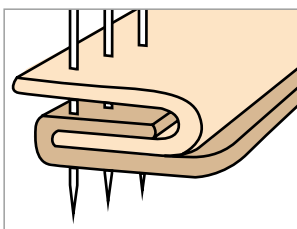

適用工作服、牛仔褲之搭縫(埋夾縫)與褲頭車縫

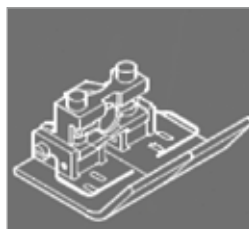

HF008A-04XX
HF088A-04XX-XXX

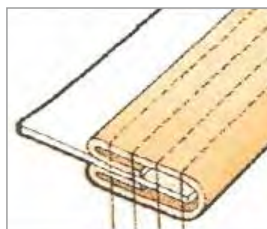

Suitable for tape binding on waistband of workwear pants, jeans.

H1



HF008A-02064P/HHD	2	4	1/4"(6.4mm)	1.8-3.6	12	UYX128GAS#14~#16	4200
HF008A-03064P/HHD	3	6	1/4"(6.4mm)	1.8-3.6	12	UYX128GAS#14~#16	4200



HF008A-02064P/HHD

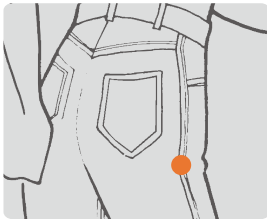

埋夾縫

適用於薄至厚料如工作服、牛仔褲之搭縫

註：一般出車，均不附喇叭，如有需要可依以上規格訂製

LAP SEAMING

To lap seaming on light to heavy material such as workwears or jeans, etc...

Remark : Folder is not included. Please specify folder no. when ordering.

可選擇之規格 Available Model		布料 Material	喇叭代號 Folder No.
02064/HHD 03064/HHD	1/4"	薄料 light	B511
		中厚料 medium	B511P
		厚料 heavy	B511Q

H2



HF008A-03064P/HTF	3	6	1/4"(6.4mm)	1.8-3.6	12	TVX5 #18~#21	4200
-------------------	---	---	-------------	---------	----	--------------	------



HF008A-03064P/HTF

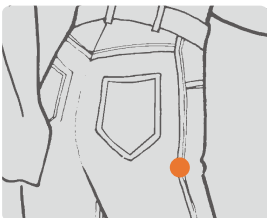

搭縫

適用於中厚布料至極厚布料如工作服、牛仔褲等粗斜紋布之搭縫用

註：一般出車，均不附喇叭，如有需要可依以上規格訂製

LAP SEAMING

To lap seaming on medium to extra heavy material such as workwears or jeans, etc...

Remark : Folder is not included. Please specify folder no. when ordering.

布料 Material	喇叭代號 Folder No.
中厚料 Medium	B511P
厚料 Heavy	B511Q
極厚料 Extra Heavy	B511R



HF008A-0464-254P/HPR	4	8	1/4-1-1/4" (6.4-25.4-6.4mm)	1.4-3.6	12	TVX5 #18~#21	4500
HF008A-0664-254P/HPR	4 (6)	8	1/8-1/8-1-1/8-1/8" (3.2-3.2-25.4-3.2-3.2mm)	1.4-3.6	12	TVX5 #18~#21	4500



HF008A-0664-254P/HPR/B530



HF008A-0464-254P/HPR

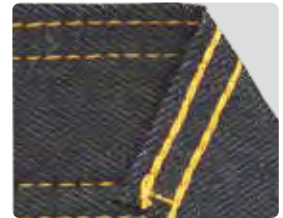
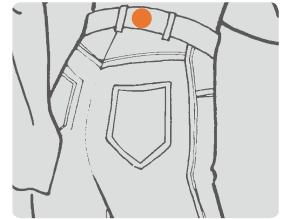

選購配件	OPTIONAL DEVICE
FH	

褲頭上帶滾邊車縫

適用於厚料之工作褲、牛仔褲等褲頭之上帶滾邊一次成型車縫，可依布條之縫合樣式選擇喇叭
 註：一般出車，均不附喇叭，如有需要可依以上規格訂製

WAISTBAND ATTACHING

For tape binding on waistband of workwear pants, jeans...etc. Refer to below table to find optional binders for desirable seams.

Remark : Binder is not included. Please specify binder no. when ordering.

選配喇叭 OPTIONAL BINDER

成品尺寸 (Finished Size)	上下片直送 For Continuous Strips	上下片弧形 For Arched Type	側送喇叭 Side Feeding	前送喇叭 Front Feeding
1" (25mm)	-	-	-	B530
1- 1/8" (29mm)	-	-	-	B530P
1- 1/4" (32mm)	B516	B518	B519	B530Q
1- 3/8" (36mm)	B516P	B518P	B519P	B530R
1- 1/2" (38mm)	B516Q	B518Q	B519Q	B530S
1- 5/8" (42mm)	B516R	B518R	B519R	B530T
1- 3/4" (45mm)	B516S	B518S	B519S	B530U
縫合樣式 Seam Type				

H4



HF008A-0464-254P/PMP	4	8	1/4-1-1/4" (6.4-25.4-6.4mm)	1.4-3.6	12	TVX5 #18~#21	4500
HF008A-0664-254P/PMP	4 (6)	8	1/8-1/8-1-1/8-1/8" (3.2-3.2-25.4-3.2-3.2mm)	1.4-3.6	12	TVX5 #18~#21	4500



HF008A-0664-254P/PMP/
B530

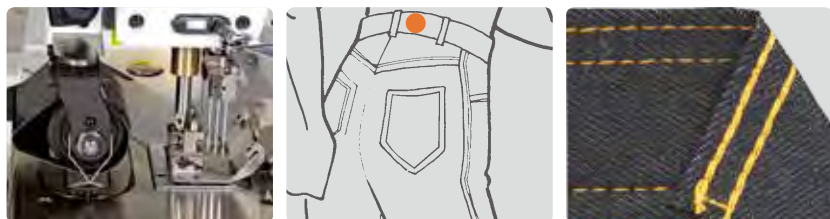

(可調整角度)褲頭上帶滾邊車縫

同HPR褲頭上帶滾邊車縫功能，但角度可進行調整；適用於有曲度之褲腰車縫。

(ANGLE-ADJUSTABLE) WAISTBAND ATTACHING

Same waistband attaching function as HPR, with adjustable angle to process curved workpieces.

H5



HF008A-02056P/FBQ	2	3	7/32"(5.6mm)	1.8-3.6	12	UYX128GAS#10~#11	4200
HF008A-02064P/FBQ	2	3	1/4"(6.4mm)	1.8-3.6	12	UYX128GAS#14~#16	4200



HF008A-02064P/FBQ

褲耳車縫 (附雙邊切刀)

用本輔助件雙邊切刀裁布之功能，可將零碎之廢布利用來製作褲耳，減少布料消耗。

BELT-LOOP SEAMING (WITH RIGHT & LEFT FABRIC TRIMMER)

This machine is equipped with an adjustable fabric trimmer to cut excess fabric edge neatly, and seaming to belt loops for saving cost and increase efficiency.

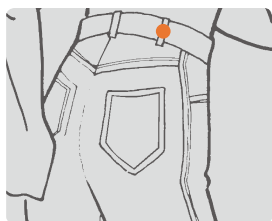

可選擇之規格 Available Model	成品尺寸 Finished Size	喇叭代號 Folder No.	適用 Application
HF008A-02056P/FBQ	9 mm	FBQ14A	男女西褲 Trousers
	10 mm	FBQ14B	
HF008A-02064P/FBQ	12 mm	FBQ14C	牛仔布 Jeans



HF008A-0464-254P/PMP/JD	4	8	1/4-1-1/4" (6.4-25.4-6.4mm)	1.4-3.6	12	TVX5 #18~#21	4500
HF008A-0664-254P/PMP/JD	4 (6)	8	1/8-1/8-1-1/8-1/8" (3.2-3.2-25.4-3.2-3.2mm)	1.4-3.6	12	TVX5 #18~#21	4500



HF008A-0664-254P/PMP/JD

牛仔褲腰車縫 (自動跳針)

車縫褲腰時可使用自動跳針機能避開不需縫製的地方

JEANS WAISTBAND ATTACHING (with Skip-stitch function)

When sewing waistband at the opening area, skip-stitch function can save your time of cutting the seam.

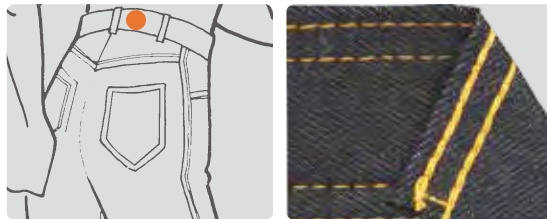

PICOTING MACHINE

One / two needle picoting chainstitch machine

Z008 - 2

48

Q

針數
Needle numbers

1
2

針距
Needle gauge

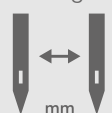

機種別 Model

Z008 外曲牙縫紉機
Picoting chainstitch machine

代碼 Code	型式 Type	車縫導片 / 壓具 Guide / Presser foot		車縫樣式 Sewing Pattern
P	單鋸齒型 Single-picot	ZB09 	P7872-A 	
Z	單鋸齒型 Single-picot	ZB11B-1A 	P7871-A 	
Q	雙鋸齒型 Double-picot	ZB09 	P7872-A 	
W	網狀對結縫 Net-picot	ZB11-A 	P7873-A 	
X	網狀對結縫 Net-picot	無	P7873-A 	
Y	雙鋸齒型 Double-picot	ZB11B-A 	P7873B-A 	

Z008 SERIES FEATURES



Z008 外曲牙縫紉機 Picoting chainstitch machine



獨特的筒型台面設計使車縫更得心順手，更適於筒狀物的車縫，整體的外觀設計使操作與技術者的維修更容易
Cylinder machine frame design to make sewing operation easier for circular cloth. Easy maintenance and adjustment.



全自動加油系統，潤滑各部零件，提升機台壽命

Automatic oiling system to lubricate all spare parts, to extend the machine lifetime.



按鈕式縫距調整裝置，簡便省時，減少一般式調整或更換零件之冗長作業

Stitch length adjustment by knob, saves time for adjustment and maintenance.



密閉式針杆及天秤結構，防止漏油

Entirely sealed needle bar and take-up design to prevent oil leakage.

可更換不同規格元件，適合多樣的鋸齒飾邊或雙鋸齒飾邊

Different gauge set can be easily changed suitable for various picot sewing.



Needle No.



Z008-248Q

2

4

3.7-7.4

1

7

U0163 #11

3500



Z008-248Q

Z型裝飾

適用於女用內衣褲、手絹、桌布、禮服、童裝、運動裝、枕套等之各種裝飾縫

ZIGZAG SEWING

Suitable for making decorative zigzag stitches on women's underwears, handkerchiefs, tablecloths, formal dresses, children's wear, sportwears and pillowcases.



DEVICE



DV¹²

下軸型直驅伺服馬達 Lower main shaft type Direct-drive servo motor

多針鏈縫機模組化搭配直驅伺服馬達，多樣化的選擇，更有彈性

¹=廠商代碼 ²=版本代碼 + 功能代碼

Double chainstitch machine equipped with the modularized direct-drive servo motors to be more flexible for diversification.

¹=Manufacturer code ²=Version code + Function code

可自行組裝 self-installation : YES

適用機型 applicable model : 全系列多針鏈縫機 All Double Chainstitch Series



FH

下固定式送帶盤 Lower Fixed Tape Holder

置於桌下方放布條或鬆緊帶

Holds tape or elastic tape under the table

可自行組裝 self-installation : YES

適用機型 applicable model : VC008(A)/VWL, VC008(A)/VWLB, VC008(A)/VWLC, VC008(A)/VSF
HF008A/HPR



HWL(P) 後拉引滾輪 Rear Puller

協助車縫後平順，不會擠壓。與針位距離72mm，讓拉布與出布更穩定

Smooths the sewing process, and no shirr. The 72 mm distance from the needle helps to stabilize the fabric during sewing process.

可自行組裝 self-installation : NO

適用機型 applicable model : HF008A



JD

跳針裝置 Skip Stitch Device

避開褲腰車縫時不需下針的地方

Control freely to avoid stitches sewed on un-wanted working area.

可自行組裝 self-installation : NO

適用機型 applicable model : VC008(A), HF008A



LSA

上固定式送帶盤 Upper Fixed Tape Holder

置於上前方放布條或鬆緊帶

Holds tape or elastic tape in front.

可自行組裝 self-installation : YES

適用機型 applicable model : VC008(B)/VPL, VC008(B)/VSF



RL

筒型衣物撐開滾輪組 Tubular Extending Roller

協助將筒型衣物撐開，便於車縫

Extends the tubular material to make sewing process easier.

可自行組裝 self-installation : YES

適用機型 applicable model : VC008(B)/VCE



VAD

氣壓式抬壓腳裝置 Pneumatic Presser Foot Lifter

利用氣壓提升壓具可提高效率

註: 1. 需有空壓設備 2. 搭配伺服馬達使用

Pneumatic presser foot lifter is used to improve operation efficiency.

Remark: 1. Compressor capability needed. 2. Servo motor needed.

可自行組裝 self-installation : YES

適用機型 applicable model : VC008(A), VC008(B)



VAR

密縫裝置 Condense Stitching Device

於車縫起始或結束時進行密縫的功能，確保縫線不易脫落，提高車縫品質

Reinforce the stitches at the beginning and end of sewing, to enhance sewing sturdiness and quality.

可自行組裝 self-installation : NO

適用機型 applicable model : VC008(A), VC008(B)



VCE

環型褲頭鬆緊帶上帶裝置 Tubular Elastic Inserting and Attaching

用於運動褲或男內褲等圓筒型衣褲上鬆緊帶包縫，本機型可有兩種縫合方式:

1. 環型鬆緊帶布料折邊縫
2. 拷克後上環型鬆緊帶包縫

Tubular elastic inserting on sportswears or man's underwears, two types of sewing functions are available:

1. To attach tubular seamless elastic waistband.
2. To cover sewing on elastic after overlock seaming.

可自行組裝 self-installation : YES

適用機型 applicable model : VC008(A), VC008(B)



VMR

雙針打折裝置 Ruffling

適用於窗簾，床單等寢具的裝飾縫及桌布或室內裝飾品之打折，由花盤(凸輪)控制可縫製各種各樣漂亮的皺褶

註: 1. 皺褶最大間距 7-8 mm

2. 六塊花盤凸輪如V15附圖

Decorative sewing on curtain and bed sheets or various ruffling patterns on table cloth or indoor decoration which controlled by cams.

Remark: 1. Maximum 7-8 mm space for shirring.

2. Six cams as listed on V15.

可自行組裝 self-installation : NO

適用機型 applicable model : VC008(A)-02064P



VCL(P) 後拉引滾輪 Rear Puller

協助車縫後平順，不會擠壓。與針位距離 72 mm，讓拉布與出布更穩定

註：各機型搭配平輪或齒輪如下表，若有異於標準品訂購時請特別註明

Smooths the sewing process, and no shirr. The 72 mm distance from the needle helps to stabilize the fabric during sewing process.

Remark: Please check the type of pullers (flat or serrated) used for different machines from the table below. If you would like to order different pullers standard, please remark when ordering other than.

滾輪 / Roller	平輪 / Flat	齒輪 / Gear
上 / Upper	VCL16P	VCL37P(27T)
下 / Lower	VCL28	VCL33P(16T)
VC008-04xxxP		S
VC008-04xxxP/VCE		S
VC008-02xxxP/VMR	S	
VC008-04xxxP/VSF	S	
VC008-04xxxP/VWL		S
VC008-06xxxP/VPL	S	
VC008-12xxxP		S
VC008-12xxxP/VCE		S
VC008-12xxxP/VPQ	S	
VC008-12xxxP/VPT	S	
VC008-12xxxP/VWL		S
VC008-12xxxP/VPQ-K	S	
VC008-12xxxP/VSM	VCL16D	
VC008-12xxxP/VSQ	VCL16D	

VCL滾輪明細表 VCL Roller List

Type	平輪 Flat Type		齒輪 Gear Type	壓花 Knurling
材質 Material	硬質塑膠 PU (Black)	軟質橡膠 Rubber (Black)	塑鋼 POM (White)	鋼質 Steel
長度 Length	80mm	80mm	80mm	78mm
上滾輪護蓋 Upper Cover	VCL39R	VCL39R	VCL39R	VCL39R
上滾輪 Upper	VCL16P *VCL16D (for VSM, VSQ)	VCL16R	VCL08P(22T) 厚 Heavy	VCL08N (22T)
			VCL37P(27T) 中厚 Medium	
			VCL60(44T) 薄 Light	
			VCL63(54T) 輕薄 Fine	
下滾輪 Lower	VCL28	VCL28R	VCL33(14T) 厚 Heavy	VCL33N(22T)
			VCL33P(16T) 中厚 Medium	
			VCL61(28T) 薄 Light	
			VCL64(32T) 輕薄 Fine	

滾輪選用原則 Puller Set Application

平輪 Flat type	塑膠 PU	適用一般薄布料，如梭織棉布 For common materials, eg: woven cotton fabric.
	橡膠 Rubber	適用貼帶車縫，或光滑薄布料使用，如梭織絲光布 For tap attaching or slippery materials, eg: woven silk fabric.
齒輪 Gear type	粗齒塑鋼 Big-teeth POM	適用鬆緊帶車縫，大折景 For elastic band sewing, big gathering
	細齒塑鋼 Fine-teeth POM	適用鬆緊帶車縫，小折景 For elastic band sewing, small gathering
鋼質壓花輪 Knurling Steel roller		適用牛仔類與厚布料 For jeans and heavy material

可自行組裝 self-installation : NO

適用機型 applicable model : VC008(B)



VPQ

彈性線抽折縫裝置 Elastic Thread Shirring

適用於女用裙皺褶·連身衣裙等腰邊鬆緊帶皺褶均能順暢縫紉·勾針底線宜用彈性線
Suitable for sewing ornamental shirring on women's blouses. Suggested to use elastic thread for lower looper.

可自行組裝 self-installation : YES

適用機型 applicable model : VC008(A)-12048P, VC008(A)-12064P



VPL

貼帶裝置 Tape Attaching

主要用於襯衫門襟·腰帶·運動衣等裝飾條帶

註: 1.喇叭成品規格如圖表

2.布條之尺寸可依3/16"或1/4"倍數變換

Decorative tape for shirt-fronting, sportswears, waist band, etc...

Remark: 1. Folder and finished goods specifications as listed in the table below

2. Tape size can be adjusted in multiples of 3/16" or 1/4".

機型 Model	完成尺寸 Finished Size(mm)	X	Y	Z	針距 Needle Gauge	壓具 Presser Foot
VC008(B)-06048P	8	B417P	B417AP	B417P	3/16"	P9412DA
	9	B417Q	B417AQ	B417Q		P9412D
VC008(B)-06064P	10	B417R	B417AR	B417R	1/4"	P9512DA
	12	B417S	B417AS	B417S		P9512D
	16	B417U	B417AU	B417U	1/2"	P9512B

可自行組裝 self-installation : YES

適用機型 applicable model : VC008(B)-06048P, VC008(B)-06064P



VPQ-K

彈性線抽折縫裝置 Elastic Thread Shirring

適用於女用裙皺褶·連身衣裙等腰邊鬆緊帶皺褶均能順暢縫紉

1.勾針底線宜用彈性線

2.增加VWL組可穩定鬆緊帶的鬆緊度讓車縫更平順美觀·不跳針

3.將彈性線安裝於桌板下·讓彈性線車縫更順暢

4.本配件為多功能·可調為VWL·VPQ單一使用

Suitable for sewing ornamental shirring on women's blouses.

1. Suggested to use elastic thread for lower looper.

2. The added VWL set will further stabilize the tension of elastic thread and make sewing process more smoothly, also can avoid stitch skipping.

3. Holds the elastic thread under the table to make sewing process more smoothly.

4. Multifunction device can be adjusted to VWL or VPQ.

可自行組裝 self-installation : YES

適用機型 applicable model : VC008(A)-12048P, VC008(A)-12064P



VPS

彈性線抽折縫裝置 Elastic Thread Shirring

適用於女用裙皺褶·連身衣裙等腰邊鬆緊帶皺褶·如:女襯衫·游泳衣·婦女用衣物·枕頭套·兒童衫。針線用彈性線·勾針為勾線功能不穿線·為101車縫式樣

Suitable for sewing ornamental shirring on women's blouses, swimsuits, pillowcases, children's shirts. Needle uses elastic thread and looper without any thread. It's 101 sewing type.

可自行組裝 self-installation : YES

適用機型 applicable model : VC008(A)-12048P, VC008(A)-12064P



VPT

折布車縫裝置(明折縫) Tucking (Visible Fold Seaming)(VPT) 折布車縫裝置(暗折縫) Tucking (Blind Fold Seaming) (VPTA)

配合多種導邊器可組合各種打折，右傾或左傾折均能完美之縫紉如：襯衫、連衣裙、衣服、兒童襯衫、尼龍褲等細條打折用

註：如購一般機型自行安裝的VPT時，VA05及VA06導邊器固定處需自行攻牙

Using various folders for different side shirring patterns, suitable for shirts, women's dress, children's shirts, nylon pants.

REMARK: When installing VPT device on standard machine, position of VA05 and VA06 folder need to be tapped first.

可自行組裝 self-installation : YES

適用機型 applicable model : VC008(A)-12048P, VC008(A)-12064P



VWL VWLB VWLC

前鬆緊帶送帶滾輪裝置 Front Elastic Feeding

鬆緊帶送帶滾輪裝置能隨機台本身之運轉，將鬆緊帶送出，且可調整鬆緊帶送出量之多寡，操作簡便；車縫慢跑褲，運動褲，休閒褲等褲頭，由於前後導輪裝置，上鬆緊帶時能保持一定張力，維持車縫品質

註 :VWL 附 B413 喇叭

VWLB 附 B411喇叭及撐開滾輪組

VWLC 附 VCE 導片

Length of elastic type can be easily adjusted by elastic feeding device, suitable for sports pants and casual pants. Roller maintains the tension of elastic thread and quality during sewing process.

REMARK: VWL with folder B413

VWLB with folder B411 and extending roller

VWLC with VCE fabric guide

可自行組裝 self-installation : YES

適用機型 applicable model : VC008(A)-04064P, VC008(A)-04085P, VC008(A)-04095P,
VC008(A)-04106P, VC008(A)-04127P, VC008(A)-12048P,
VC008(A)-12064P



VSC

鬆緊帶抽皺縫裝置 Elastic Thread Shirring Sewing

彈性線直送不打線圈，由針線與勾針線上下包覆，車縫成品效果較VPQ薄，且皺褶可拉伸至完全平坦

Elastic thread is straight, not looped, which is fixed by needle thread and looper thread. The finish is thinner than VPQ and the shirring becomes flat as it is pulled extensively.

可自行組裝 self-installation : NO

適用機型 applicable model : VC008(A)-12048P, VC008(A)-12064P



VSF

門襟車縫裝置 Shirt-Fronting

對於各種襯衫門襟用四針或二針，因有專用滾邊器配合使用，只要一道工序即可完成，連續縫紉非常順暢。喇叭尺寸如圖表：

Using 4 or 2 needle and special folder for shirt-fronting, only one sewing process is required. Size of folder as listed in the table below.

規格Spec 代號Code	完成尺寸 Finished Size	入布寬度 Tape Size	針距 Needle Gauge	機型 Model
B529	1-3/8"	2-3/8"	1/4 - 3/4 - 1/4"	VC008-0464-191P
B529P	1-1/2"	2-1/2"	3/16 - 1 - 3/16"	VC008-0448-254P
B529Q	1-5/8"	2-5/8"	1/4 - 1 - 1/4"	VC008-0464-254P

可自行組裝 self-installation : YES

適用機型 applicable model : VC008(B)-0448-254P, VC008(B)-0464-191P,
VC008(B)-0464-254P



VSM

花飾縫裝置 Decorative Sewing

由16個花盤變化·利用針線之搭配·可縫製數十種不同花樣·適用於高級衣飾、窗簾、床罩等寢具的裝飾縫及桌巾或室內裝飾品之花飾縫

To use sixteen different cams of variation for different sewing, suitable for decorative sewing on high quality dresses, curtains, bed sheets and tablecloths.

可自行組裝 self-installation : NO

適用機型 applicable model : VC008(A)-12048P, VC008(A)-12064P



VSSM

花飾縫 Decorative Sewing

由16個花盤變化·利用針線之搭配·可縫製數十種不同花樣·適用於高級衣飾、窗簾、床罩等寢具的裝飾縫及桌巾或室內裝飾品之花飾縫

To use sixteen different cams of variation for different sewing, suitable for decorative sewing on high quality dresses, curtains, bed sheets and tablecloths.

可自行組裝 self-installation : NO

適用機型 applicable model : VC008(A)-12048P, VC008(A)-12064P



VSQ

鬆緊花飾縫裝置 Decorative Sewing with Elastic Thread Shirring

由16個花盤變化·利用針線之搭配·可縫製數十種不同花樣·適用於高級衣飾、窗簾、床罩等寢具的裝飾縫及桌巾或室內裝飾品之花飾縫

To use sixteen different cams of variation for different sewing, suitable for decorative sewing on high quality dresses, curtains, bed sheets and tablecloths.

可自行組裝 self-installation : YES

適用機型 applicable model : VC008(A)-12048P, VC008(A)-12064P



VUT

自動切線裝置 Pneumatic Automatic Thread Trimmer

氣動式自動切線可提高車縫效率節省成本

Pneumatic automatic thread trimmer increases operation efficiency and saves the cost.

可自行組裝 self-installation : NO

適用機型 applicable model : VC008(B)-04064P, VC008(B)-04085P, VC008(B)-04095P,
VC008(B)-04106P, VC008(B)-04127P, VC008(A)-12050P

VC008 彈性線機型對照/ VC008 Comparison on Elastic Thread Models

型號 Model	布樣 Sample Fabric	面線(針線) Surface Thread (Needle Thread)	底線(勾針線) Rear Thread (Looper Thread)	花樣線 Decorative Thread	備註 Remark
VPQ		一般 Standard	彈性線 Elastic	-	
VPQK		一般 Standard	彈性線 Elastic	-	車縫與VPQ完全相同 差別在多加VWL下送輪, 使底線控線穩定 Same stitch as VPQ. The difference is on the front roller, VWL, which stabilizes rear thread controls.
VPS		彈性線 Elastic	無 None	-	勾針不穿線 Looper without thread.
VSM		一般 Standard	一般 Standard	√	可平,也可皺褶 Flat or shirring at options
VSQ		彈性線 Elastic	無 None	√	功能=VPS+VSM 彈性線抽皺褶 Function equates VPS plus VSM. Elastic shirring.
VSC		一般 Standard	一般 Standard	-	彈性線拉直,由底線與面線包 Elastic thread is stretched and covered by rear thread and surface thread.
VSSM		一般 Standard	彈性線 Elastic	√	功能=VSM+VPQ Function equates VSM plus VPQ.

TABLE

桌板代號 Item No.	尺寸 / Size (mm)			說明 Description	適用機型 Applicable Model	備註 Remark
	長 Length	寬 Width	厚 Thickness			
VC008-T1	1200	540	45	半沉式 Semi-submerged	VC008(A/B)-04 VC008(A/B)-04P/VCE, VUT, VSF	
VC008-T2	1200	540	45	上乘式 Non-submerged		
VC008-T3	1200	540	45	半沉式 Semi-submerged	VC008(A/B)-06/VPL, VC008(B)-11, VC008(A/B)-12, VC008(A)-12/VPQ, VC008(A/B)-12/VPT, VC008(A/B)-12/VUT, VC008(A)-13	
VC008-T4	1200	540	45	上乘式 Non-submerged		
VC008-T5	1200	540	45	半沉式 Semi-submerged	VC008(A)-04/VWL, VWLB, WWLC	
VC008-T6	1200	540	45	半沉式 Semi-submerged	VC008(A)-12/VPQK, VWL, VSSM	
VC008-T7	1200	540	45	半沉式 Semi-submerged	VC008(A)-02/VMR	
VC008-T8	1200	540	45	半沉式 Semi-submerged	VC008(A)-12/VSM, VSQ	
VC008-T9	1200	540	45	半沉式 Semi-submerged	VC008(A)-12/VSC	
VC008-T10	1200	540	45	全沉式 Full-submerged	VC008(A/B)-04, VC008(A)-12	需搭配 SM899-A SM899-A set required
HF008-T1	1200	540	45	半沉式 Semi-submerged	HF008(A)	
HF008-T4	1200	540	45	半沉式 Semi-submerged	HF008(A)/FBQ	
Z008-T1	1200	540	45	半沉式 Semi-submerged	Z008	
Z008-T2	1200	540	45	上乘式 Non-submerged	Z008	

ONE NEEDLE LOCKSTITCH MACHINE

DL7200

-

R HM

1

A

-

17

機種別 Model

DL720 直驅單定針平縫車
Direct-drive needle positioning lockstitch machine

DL7200 直驅式自動切線平縫車
Direct drive lockstitch machine with thread trimmer

DL7200B 直驅式自動切線平縫車
(超短線頭, 密封油盤)
Direct drive lockstitch machine with thread trimmer (short remaining thread, sealed oil tank)

DL7400 新世代電腦平縫機
(雙步進馬達系統)
New Generation Computer Single Needle Lockstitch machine (Dual-stepper motor system)

DL7300 直驅式自動切線右切刀平縫車
Direct-drive lockstitch machine with thread trimmer and right-edge trimmer

特性 Features

R 右切刀
Vertical edge trimmer

B 旋轉式切線系統
Rotary thread trimming

N 針送布
Needle feed

車縫布料 Sewing Material

L 薄布料
Light

M 中厚布料
Medium

H 厚布料
Heavy

HM 中厚至厚布料
Medium & heavy

X 牛仔料
Jeans

旋梭 Hook

1 高速縫梭頭
High speed hook

2 大旋梭
Large Hook

送布牙 Feed Dog

- 四排牙
4 rows of teeth



A 三排牙
3 rows of teeth



功能選配 Function Option

功能碼 Function	快速倒縫 Reverse feeding	拔線杆 Wiper	電子夾線 Thread	自動抬壓腳 Auto lifter	防鳥巢 Bird nest prevention
11	V	V	-	-	-
12	V	-	-	V	-
13	V	V	-	V	-
15	V	-	V	-	-
16	V	-	V	V	-
17	V	-	V	V	V

Energy saving 節能
Stable 穩定
Direct-drive 直驅



DL7200B

DL7200B | SERIES DL7400 | SERIES

直 驅 單 針 平 縫 機
Direct-drive Single-needle Lockstitch Machine



DL7400

DL7200B SERIES FEATURES



延續DL7200優異的車縫性能，再新增特點
Following the excellent sewing performance of DL7200, and added the new features

1 新切線機構：超短切線線頭(3mm)
 傳統的切線機構為一組固定刀與活動刀，新切線機構為雙動刀設計，在最接近針板處，進行切線動作，達成超短線頭效果

**New trimming mechanism:
 Very short trimmed thread end (3mm)**
 Traditional trimming mechanism is a pair of fixed knife and moving knife. The new trimming mechanism is a pair of dual-moving knives. Thread trimming is made at the point near the needle plate to have a very short trimmed thread end.

2 封閉式油盤
 傳統的油盤為開放式，DL7200B以封閉式設計，確保機油不飛濺

Sealed oil tank
 Traditional oil tank is open type. DL7200A's oil tank is sealed type, which the oil will not come out from the machine.

3 新型操作面板
 - 設定參數圖示化，並有中英文提示，直覺式操作，不需查閱說明書
 - 各項功能的快速鍵：分區，動線設計良好

New control panel
 - Parameters are shown by graphic with English and Chinese, which makes intuitive operation and no need to check manual book.
 - Hot keys of the functions: layout and setting route are clear.

4 防鳥巢功能 (選配)
 可避免起縫時，在底面的「鳥巢」現象，對於各種壓明線的工序，例如標籤車縫，可以提高車縫品質與效率

Bird nest prevention (optional)
 The device avoids the "bird nest" problem on the bottom side, which happens at the sewing starting. Applicable to the sewing of top stitch e.g. label attaching, which improves the sewing quality and the efficiency.



規格

SPECIFICATIONS

L4	 mm	 mm	 mm		Needle No. DBX1	 S.P.M.(Max)	功能選配 Function Option				
			手動 Hand	自動 Auto			代碼 Function Code	倒縫 Reverse Feeding	電子夾線 Thread Nipper	抬壓腳 Auto Lifter	防鳥巢 Bird nest prevention
DL7200B-BH1	0-6	15.5	5.5	10-13	#20~#23	3500	15	√	√	-	-
DL7200B-BM1	0-5	18	5.5	10-13	#11~#14	4000	16	√	√	√	-
							17	√	√	√	√

DL7400 SERIES FEATURES

DL7400 新世代電腦平縫機 New Generation Computer Single Needle Lockstitch machine



- 雙步進馬達驅動，實現完美的連貫動作
 - 起縫微鳥巢，結束短線頭，實現優美的車縫品質
 - 完整而優良的各項細節
- Dual-stepper motor drive for the perfect coherent movements
 - Starting with micro-bird nest, ending with short thread end, for the beautiful sewing quality
 - Complete and excellent details

特點

FEATURES



雙步進馬達驅動，實現完美的連貫動作

底部的步進馬達控制雙動刀切線與抬壓腳，右側的步進馬達控制針距與倒縫，以電控技術串聯每一個縫紉機功能，實現完美的連貫動作

Dual-stepper motor drive for the perfect coherent movements

The bottom stepper motor controls the double-moving-knife thread trimmer and presser foot lifter, and the right side stepper motor controls the stitch distance and reverse stitch. The computer control technology integrates every function of the sewing machine, and realize the perfect coherent movements.

起縫微鳥巢，結束短線頭，實現優美的車縫品質

完美的連貫動作，起縫時機針上只需極短線頭，大幅降低底面的鳥巢現象，穩定的雙動刀切線，可達3 mm以下的短線頭，實現優美的車縫品質

Starting with micro-bird nest, ending with short thread end, for the beautiful sewing quality

Due to the perfect coherent movements, it requires a very short thread end at the needle at the sewing starting, which significantly reduces the bird nest on the bottom side. The double-moving-knife thread trimmer is very stable, and it makes the ending with Max. 3 mm thread end, which realize the beautiful sewing quality.



DL7400



普通平縫機

完整而優良的各項細節
Complete and excellent details

<p>照明與快速鍵三合一模組 Lighting and hot key 3-in-1 module</p>		<p>電子膝控抬壓腳 Electronic knee touch presser foot lifter</p>	
	<p>超大液晶觸控面板 Large LCD touch panel</p>		<p>密縫油盤 Sealed oil tank</p>  <p>USB 充電埠 USB charging port</p>

規格

SPECIFICATIONS

L2	 mm	 mm	 mm		Needle No. DBX1	 S.P.M.(Max)
			手動 Hand	自動 Auto		
DL7400-BH1	0-6	15.5	5.5	10-13	#20~#23	4000
DL7400-BM1	0-5	18	5.5	10-13	#11~#14	5000

功能選配 Function Option				
代碼 Function Code	倒縫 Reverse Feeding	電子夾線 Thread Nipper	抬壓腳 Auto Lifter	防鳥巢 Bird nest prevention
16	√	√	√	-
17	√	√	√	√

DL720 SERIES FEATURES

DL720 直驅單定針平縫機 Direct-drive needle positioning lockstitch machine



- 機電一體化的完美整合，內置電控箱及控制台，安裝簡易，使用方便
 - 直驅伺服馬達，反應快速，動作精準，比離合器馬達省電 60%
 - 使用方便：配備 LED 照明，內置式繞線器，與補針功能
-
- Mechatronic integration with built-in control box and control panel. It is easy to install and operate.
 - Direct-drive servo motor is speedy, accurate, and energy-saving than clutch motor by 60%.
 - User friendly: Equipped with LED light, built-in bobbin winder, and half stitch function.

規格/ SPECIFICATION

L1						選配桌板 Optional Table
DL720-M1	0-4	15.8	手動 Hand lifter 5.5mm	#11~#14	4000	DL7000T-T1
DL720-H1	0-5	18.0		#18~#21	3500	
DL720-M1A	0-4	15.8	膝動 Knee lifter 13mm	#11~#14	4000	

DL7200 SERIES FEATURES



操作空間大，方便縫製物移動
Working space is wide for moving sewing material.



安全開關，機器傾斜時即停機，確保安全
Safety switch : Stops running when the machine is tilted to ensure safety.



採用小型直驅伺服馬達，起縫快速，定位精準，低噪音，無皮帶屑污染
Mini direct drive servo motor system provides quick start sewing, precise positioning, low noise, and no belt dust.

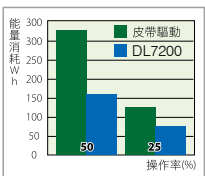

耗能小，較皮帶驅動可節能35%
Low power consumption, it saves 35% energy against V-belt driving.



全自動供油確保機器在高速下的耐用性
Auto-lubrication ensures the mechanism's durability in high speed.



最大針距可達4針/英寸
Maximum stitch length is up to 4 stitch/ inch.



[選配] 不銹鋼車布導板
[Optional] Stainless steel sewing bed



圓刀式切線，棉線、絲光線均可輕易切斷
Rotary thread trimmer is applicable to various type of thread.



可調節亮度的LED燈
Adjustable LED light.



配備電子夾線器，補針按鍵安裝在倒縫按鍵的上方，方便工人操作
Equipped with electric thread nipper. Half-stitch key is set above the reverse key for easy using.

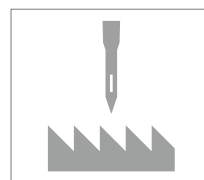

針送機構 (NM · NH) : 針送機構提供安定且強韌的送布力，針與布的不同步動作使線跡整齊，避免錯位的發生

Needle Feed Model(NM, NH): The needle-feeding mechanism provides stability and efficiency of feed, and prevents uneven material feed effectively.

規格/ SPECIFICATION

L3	mm	mm	mm	Needle No. DBX1	S.P.M.(Max)	功能選配 Function			
						代碼 Function Code	倒縫 Reverse Feeding	電子夾線 Thread Nipper	抬壓腳 Auto Lifter
DL7200-BH1	0-6	15.5	手動 Hand 5.5	自動 Auto 10-13	#20~#23	3500			
DL7200-BM1	0-5	18			#11~#14	4000			
DL7200-BX2	0-7	18			#20~#23	3500			
DL7200-NM1	0-4	14.7			#11~#14	4000			
DL7200-NH1	0-5	14.7			#20~#23	3500			
						15	√	√	
						16	√	√	√

DL7300 SERIES FEATURES



DL7300

直驅式自動切線右切刀平縫車
Direct-drive lockstitch machine with thread trimmer and right-edge trimmer



具有右切刀機構，車縫中可同步進行布料的切邊工序，使完成品的邊緣平整美觀
Equipped with vertical edge trimmer. While sewing, trimmer can cut the material at the same time to make neat edge appearance.



切刀之運作與暫停，可以輕鬆的按壓切換
Trimmer can be easily operated by one-touch control from top.



切刀機構優化設計，刀架不易磨損，使用壽命長
Superior trimmer mechanism, with better durability and longer product life cycle.







直驅伺服馬達節能省電，有簡易定針型與自動切線型，供客戶選擇
Energy-saving direct drive servo motor, can choose between needle position function or auto thread trimmer.



簡易定針型可選配喇叭組，可進行布條滾邊車縫 (喇叭為三折捲，入布寬度28mm，出布寬度8~10mm)
Needle position function models can equip with binders(optional), to perform tape binding. (Binders are with 3 folders; entering width is 28mm, exiting width is 8~10mm for material.)

規格/ SPECIFICATION

L5						Needle No. DBX1		自動切線車選配 Auto Thread Trimmer M/C Option			選配 Optional
			手動 Hand	自動 Auto				代碼 No.	快速倒縫 Reverse Feeding	電子夾線 Thread	桌板 Table
DL7300-RM1-□□-15	0-4	30.7			32,48,64	#14	4000	15	V	V	DL7000T-T1
DL7300-RM1-□□	0-4	30.7	4	10-13	32,48,64	#14	4000	-	-	-	
DL7300-RM1-□□/S	0-4	30.7			32,48,64	#14	4000	-	-	-	

TWO NEEDLE LOCKSTITCH MACHINE

T8200

42

-

064

M

L

/

C

機種別 Model

T8200 微油式雙針平車
Minimum lubrication type two needle lockstitch machine

DT8200 直驅微油式雙針平車
Direct-drive, minimum lubrication type two needle lockstitch machine

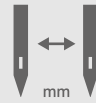

No.	mm	inch
028	2.8	1/10"
032	3.2	1/8"
040	4.0	5/32"
048	4.8	3/16"
064	6.4	1/4"
079	7.9	5/16"
095	9.5	3/8"
159	15.9	5/8"
191	19.1	3/4"
222	22.2	7/8"
254	25.4	1"
381	38.1	1 1/2"

車縫布料 Sewing Material

- L 薄布料
Light
- M 中厚布料
Medium
- H 厚布料
Heavy

旋梭 Hook

- L 敞開式
Latch type
- 有蓋式
Cap type

自動切線 Auto thread trimmer

	機型 Machine Series	撥線 Thread Wiper	抬壓腳 Presser foot lifer
C	T828	V	V
C-11	DT8200	V	
C-13	DT8200	V	V

功能 Function

規格 Sub-class	針送 Needle feed	標準旋梭 Standard hook	大旋梭 Big hook	倒縫 Reverse feeding	角縫 Split needle bar
42	V	V	-	V	-
45	V	V	-	V	V
72	V	-	V	V	-
75	V	-	V	V	V

T8200/DT8200 SERIES FEATURES

T8200

微油式雙針平車

Minimum lubrication type two needle lockstitch machine

DT8200

直驅微油式雙針平車

Direct-drive, minimum lubrication type two needle lockstitch machine

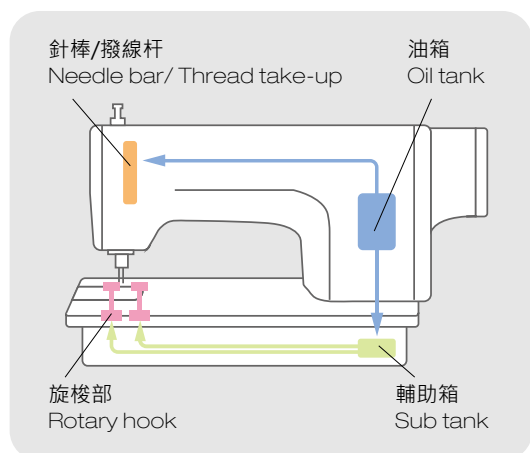

微油潤滑

採用密閉式油箱，微量供應乾淨機油，精準送達特定機構

Minimum lubrication

With a sealed oil tank, accurately supplying clean oil to the specific mechanism.

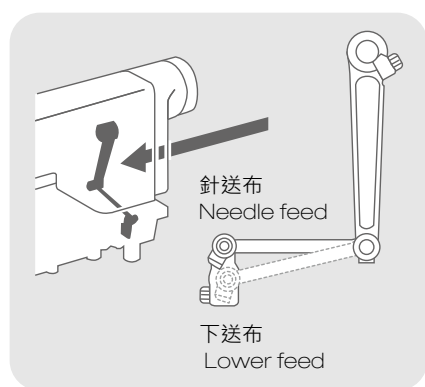

針送/下送模式切換

· 可依車縫情形，切換送布功能

· 上下綜合送連杆機構，以油脂密封的潤滑設計，確保機構動作輕順

Needle-feed/ Lower-feed mode switch

· According to the sewing condition, customers may change the fabric feeding.

· Top/ Bottom feed connecting rod mechanism is applied with grease sealed type lubrication design to ensure the smooth movement.



容易更換針距

旋梭座的左右調整機構，採用凸輪設計，微調容易。具有旋梭&機針間隙修正功能，使用市售規格組便品，也能準確微調勾線時位

Easy gauge conversion

Fine tune is easy due to the cam design for the hook base's adjusting mechanism. The needle-to-hook gap correction function ensures the needle to be at the hole center, even to use commercially available gauge sets.



面料適用範圍廣

送具的傾斜度與高度，皆可容易調整。挑線量也可調節，因此，從薄至中等厚度皆可適用

Big application range of sewing material

The feed dog's slope and height are easily adjusted. The thread take-up is adjusted, too, so the application range of sewing material is big from light to medium

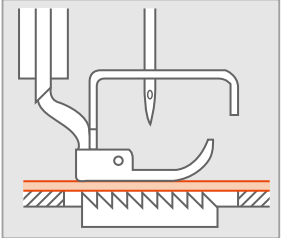

更好的車縫品質

稍微調高壓腳就可以有浮動式壓腳功能，適用於特殊布料，如彈性布料，刷毛布，可防止布料損傷，並且方便車縫曲線

Better sewing quality

Slightly raise presser foot to have floating presser foot function, applicable to special materials such as elastic fabric or fleece. It prevents from fabric damage, and is easy for curve sewing.

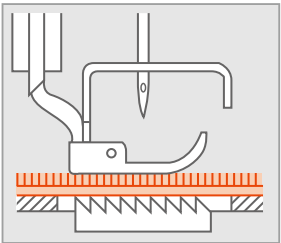

分離式針棒機型 (-45/-75)

單針 / 雙針模式切換，操作容易。採用安全設計，單針車縫時不會因誤觸切換杆而造成針棒落下

Split needle bar type (-45/-75)

One / Two needle mode switching is easy. With safety design, one needle mode is safe as needle bar will not drop by accident touch of the switch during sewing.







直驅自動切線機型(DT8200)

- 節能省電，低噪音與振動
- 反應靈敏，啟動速度的模式可選擇，
- 馬達強勁，機針貫穿力大
- 切線時位調整容易

Direct-drive thread trimmer type (DT8200)

- High energy saving, low noise and vibration
- Quick response, starting speed's mode is adjustable.
- Powerful motor, needle penetration power is strong.
- Thread trimmers timing is easy to be adjusted.

T3						馬達 Motor	倒縫 Reverse Feeding	撥線杆 Wiper	抬壓脚 Lifter
	mm	mm	Needle No. DPX5	mm	S.P.M. (Max)				
T8200-42-□□□M/ML	4	7/13	#14	*	4000	T32XXDX TSA-550			
T8200-42-□□□H/HL	5		#22		3000				
T8200-45-□□□M/ML	5		#14	032 064	3000				
T8200-45-□□□H/HL	5		#22		3000				
T8200-72-□□□H/HL	7		#22		3000				
T8200-75-□□□H/HL	7		#22		3000				
DT8200-42-□□□M/ML	4		#14	*	4000	Direct-drive AC Servo motor			
DT8200-42-□□□H/HL	5		#22		3000				
DT8200-45-□□□M/ML	5		#14	032 064	3000				
DT8200-45-□□□H/HL	5		#22		3000				
DT8200-72-□□□H/HL	7		#22		3000				
DT8200-75-□□□H/HL	7		#22		3000				
DT8200-42-□□□M/ML/C-11	4		#14		3000		V	V	
DT8200-42-□□□H/HL/C-11	5		#22		3000		V	V	
DT8200-45-□□□M/ML/C-11	5		#14	3000	V		V		
DT8200-45-□□□H/HL/C-11	5		#22	3000	V		V		
DT8200-72-□□□H/HL/C-11	7		#22	3000	V		V		
DT8200-75-□□□H/HL/C-11	7		#22	3000	V		V		
DT8200-42-□□□M/ML/C-13	4		#14	3000	V		V	V	
DT8200-42-□□□H/HL/C-13	5		#22	3000	V		V	V	
DT8200-45-□□□M/ML/C-13	5		#14	3000	V		V	V	
DT8200-45-□□□H/HL/C-13	5		#22	3000	V		V	V	
DT8200-75-□□□H/HL/C-13	7		#22	3000	V		V	V	
DT8200-75-□□□H/HL/C-13	7		#22	3000	V		V	V	

* 028,032,040,048,064,079,095,127,159,191,222,254,381

TABLE

桌板代號 Item No.	尺寸 / Size(Mm)			說明 Description	適用機型 Applicable Model
	長 Length	寬 Width	厚 Thickness		
DL7000T-T1	1200	540	45	半沉 / 上乘式 Semi-submerged / Non-submerged	DL720, DL7200, DL7200B, DL7300, DL7400
T8200-T	1200	540	45	半沉 / 上乘式 Semi-submerged / Non-submerged	T8200
DT8200-T	1200	540	45	半沉 / 上乘式 Semi-submerged / Non-submerged	DT8200



PS-2516A-01A

PS SERIES

直驅可程式電子花樣機
Direct-drive Programmable
Electronic Pattern Sewing Machine

- | | |
|-----------------|-----------------|
| PS-1010A-01S | PS-2516A-01A |
| PS-1010A-01A | PS-3020A-01A |
| PS-1010A-01A/SS | PS-3020A-01A/HM |
| PS-1310A-01S | PS-3020A-01A/MY |
| PS-1310A-01A | PS-3525A-01A |
| PS-1510A-01S | PS-4030A-01A |
| PS-1510A-01A | PS-6040A-01A |
| PS-2210A-01A | |
| PS-2210A-01A/KX | |
| PS-2210AL-01A | |



PS-6040A-01A

PS SERIES

Direct-drive Programmable Electronic Pattern Sewing Machine

PS 1010 A L - 01 A / SS

縫製範圍(X x Y mm) Sewing Area (X x Y mm)	
1010	100 X 100
1310	130 X 100
1510	150 X 100
2210	220 X 100
2516	250 X 160
3020	300 X 200
3525	350 X 250
4030	400 X 300
6040	600 X 400

版本別
Generation

車縫臂長
Sewing Bed

□: 標準
Standard

L: 長臂型
Long Arm

壓腳驅動方式
Work clamp driving type

A: 氣動
Pneumatic

S: 馬達驅動
Motor drive

應用
Application

01 厚料(#20 線)
Heavy material (#20 thread)

02 中厚料(#50 線)
Medium material (#50 thread)

03 安全帶(#4 線)
Seat belt (#4 thread)

選配配件 Optional Device	
SS	側移壓腳 Side shift clamp
FZ	反轉壓腳 Inverted Clamp
MY	帽沿 Cap brim
HM	快速換模 Template fast changing
KX	開口袋 Pocket welting



PS-2210AL-01A

新一代伺服步進驅動技術

馬達運行更精準，長時間工作狀態下，馬達溫升低，回應速度更快

New Generation Servo-stepping driving technology

The motor runs more accurately, and the response speed is faster. The temperature rises lower under long working conditions.

採用高階直驅馬達

最高速度達到2800rpm，生產效率進一步提高，起動與停車反應迅速，與傳統型相比縮短19%，提高生產效率，耗電低，經濟實用，與傳統型相比減少50%

High quality direct-drive servo motor

As the maximum speed reaches 2800 rpm so the production efficiency is more improved. The start / stop response is rapid, which is 19% shorter than the conventional type. Low power consumption makes it economy and practical, which is 50% lower than the conventional type.

以0.05mm的最小解析度實現美觀的縫紉線跡

每脈衝0.05的高解析度，PS系列可縫製出滑順的曲線，並且可做簡單的繡花圖案，就連一般刺繡機很難勝任的厚面料刺繡也可完成

The min. resolution 0.05mm realizes perfect sewing quality.

With a high resolution of 0.05 per pulse, PS series can make a smooth curve, and a simple embroidery pattern. Even a thick fabric embroidery is available, which is difficult for a typical embroidery machine.

標配斷線感測器

發生斷線時，可偵測並立即停機，報警提示

Thread breaking sensor is standard equipped

When it happened thread breaking, the machine senses the problem and then stop with alarm.

可選配數碼夾線器

傳統方式以手感調整面線張力，配備數碼夾線器可以數位化設定，實現穩定的縫製品質

**Digital thread nipper is optional**

Adjusting the upper thread tension with human feeling is the old way. With the digital thread nipper can be set easily to realize the stable sewing quality.

裁片定位簡單準確

馬達驅動式抬壓腳 (S type)的行程，可選擇設定為1步或2步下降

Sewing material setting is easy and accurate

Motor-drive type presser foot (S type) can be set the stroke as 1-step or 2-step.

均勻穩定的收線

在低張力下，可以穩定收線，由於中壓腳的高度可以改變，即使面料厚度有段差的變化，也可保持適當壓力，確保均勻穩定的收線效果

Stable and uniform seam tightness

Under low tension condition, the seam tightness can be stabilized. Because the height of the intermediate presser can be changed, even if the thickness of the fabric changes as a step, the proper pressure can be maintained to ensure a uniform and stable seam tightness.



特點

FEATURES

搭載WIFI功能，與生產管理系統快速對接，即時傳輸設備的縫紉資料
支持多種媒體，搭載1個SD卡插槽、2個USB埠

Built-in WIFI function for easy connection to production management system and sewing data real-time transmission.

Multi-data input with 1 SD card slot and 2 USB ports.

使用“NS600”程式設計軟體

可快速簡便的編輯花樣，更可相容“VDT、SEW”等格式花樣，修改花樣更簡便，可根據圖示和命令，輕鬆創建縫紉資料

NS600 pattern editing software

Easy pattern editing by computer. VDT, SEW, and the other format compatible.



- 程式編程畫面，使用說明圖示，可輕鬆創建縫紉程式
Pattern editing panel with instruction for easy creating your sewing patterns.

Pattern editing panel with instruction for easy creating your sewing patterns.

- 簡潔的縫紉資料修改區，可快速修改花樣圖形準確實現需要的縫紉資料
Compact sewing data tuning area for quick modification.

Compact sewing data tuning area for quick modification.

- 功能區選擇介面，圖形化顯示，便於使用者選擇
Function selection area with graphical display for user friendly.

Function selection area with graphical display for user friendly.



- 直觀顯示縫紉資料，無需調取其他介面查看
Intuitive display of sewing data without changing the page.

- 資料讀入讀出簡單快捷，一鍵完成
Input and output easily.

配件

DEVICE



MY 帽沿
Cap brim



HM 快速換模
Template fast changing



KX 開口袋
Pocket welting

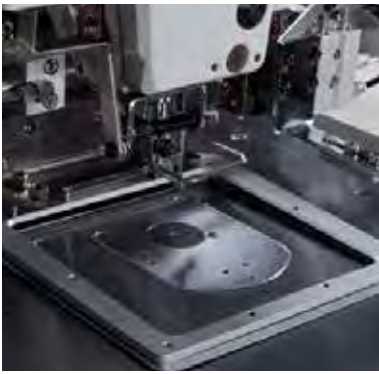

SS 側移壓腳
Side shift clamp



FZ 反轉壓腳
Inverted Clamp

規格

SPECIFICATION

- PS-1010A-01S
- PS-1010A-01A
- PS-1010A-01A/SS
(100X100 mm)
- PS-1310A-01S
- PS-1310A-01A
(130X100 mm)
- PS-1510A-01S
- PS-1510A-01A
(150x100mm)



- PS-2210A-01A
(220x100mm)
- PS-2516A-01A
(250x160mm)



PS-2210AL-01A
(220 X 100 mm)

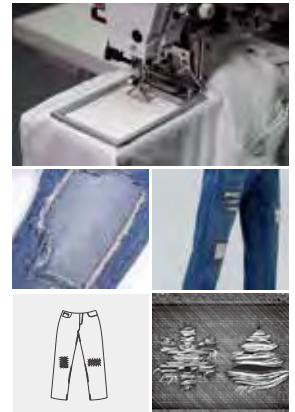

PS-3020A-01A
PS-3020A-01A/HM
PS-3020A-01A/MY
(300 X 200 mm)
PS-3525A-01A
(350 X 250 mm)
PS-4030A-01A
(400 X 300 mm)

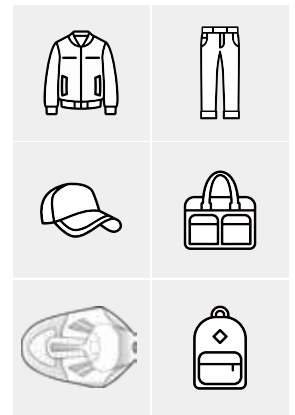

PS-6040A-01A
(600 X 400 mm)

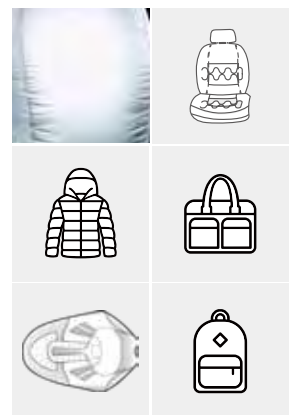

規格 Specification	1010A-01S	1310A-01S	1510A-01S	2210A-01A	2516A-01A	3020A-01A	3525A-01A	4030A-01A	6040A-01A
	1010A-01A	1310A-01A	1510A-01A	2210A-01A/KX		3020A-01A/HM			
	1010A-01A/SS			2210AL-01A		3020A-01A/MY			
線跡 Stitch Type	單針鎖縫 Single Needle Lockstitch								
最高縫製速度 Max. Sewing Speed	2800 SPM								
縫製區域 (X x Y) Sewing area (X x Y)	100 X 100	130 X 100	150 X 100	220 X 100	250 X 160	300 X 200	350 X 250	400 X 300	600 X 400
送布方式 Feeding	間歇性送布 (脈衝馬達驅動) Intermittent Feeding (Pulse motor drive mode)								
針距 Stitch length	0.05~12.7 mm								
最大針數 Max. stitch	20,000 針 / 圖形 20,000 stitch / pattern								
壓腳驅動方式 Work Clamp Drive	S: 脈衝馬達驅動 A: 氣動式 S: Pulse motor drives A: Pneumatic drive			氣動式 Pneumatic drive					
壓腳上升量 Work Clamp Lift Amount	S: Max. 25mm A: Max. 30 mm			Max. 30 mm					
兩步壓腳 2-step work clamp	S: 左右一體式 A: 左右分離式 S: Integrated-type A: Separate-type			左右分離式 Separate-type					左右一體式 Integrated-type
間歇壓腳上升量 Stepping Presser foot Height	22 mm								
間歇壓腳行程 Stepping Presser foot Stroke	0 或 2~10mm (出廠預設3mm) 0 or 2~10mm (Default setting 3mm)								
旋梭 Hook	半回轉2倍梭 Double Capacity Shuttle Hook								
掃線 Thread Wiper	選配 Standard								
切線 Thread Trimmer	選配 Standard								
數碼夾線器 Digital Tension	選配 Optional								
斷線感測器 Thread Breakage Detector	標配 Standard								
外部資料儲存 External Data storage	經由 USB 埠 Inputted by USB Port								
馬達 Motor	直驅式 AC 伺服馬達 750W Direct-drive AC Servo Motor 750W								
電源 Power	單相 220V, 三相 380V Single Phase 220V, 3-Phase 380V								
重量 Weight	機頭: 88 kg, 電控箱: 14~16kg Machine Head: 88 kg, Control Box: 14~16kg			機頭: 166 kg, 電控箱: 14~16kg Machine Head: 166 kg, Control Box: 14~16kg	機頭: 174 kg, 電控箱: 14~16kg Machine Head: 174 kg, Control Box: 14~16kg			機頭: 184 kg, 電控箱: 14~16kg Machine Head: 184 kg, Control Box: 14~16kg	機頭: 224 kg, 電控箱: 14~16kg Machine Head: 224 kg, Control Box: 14~16kg
氣壓/用風量 Air Pressure/ Consumption	0.5MPa 1.7L/min								

BT SERIES

Electronic High-speed Lockstitch Bartacking / Button Sewing/ Small Area Pattern Sewing Machine

BT

430

A

-

01

版本別
Generation

機種別 Model	
430	套結 Bartacking
438	釘扣 Button sewing
439	立扣 Shank Button
530	2合1 套結/釘扣 2-in-1 Bartacking/ Button
630	小型花樣機(6X8) Small Pattern Sewing (6X8)

車縫應用
Sewing Application

01	標準 Standard
02	厚料 Heavy material
03	帽眼 Radial tacking
05	褲耳 Belt loop
06	鬆緊帶拼接 Elastic Band Joining
07	針織 Knits material

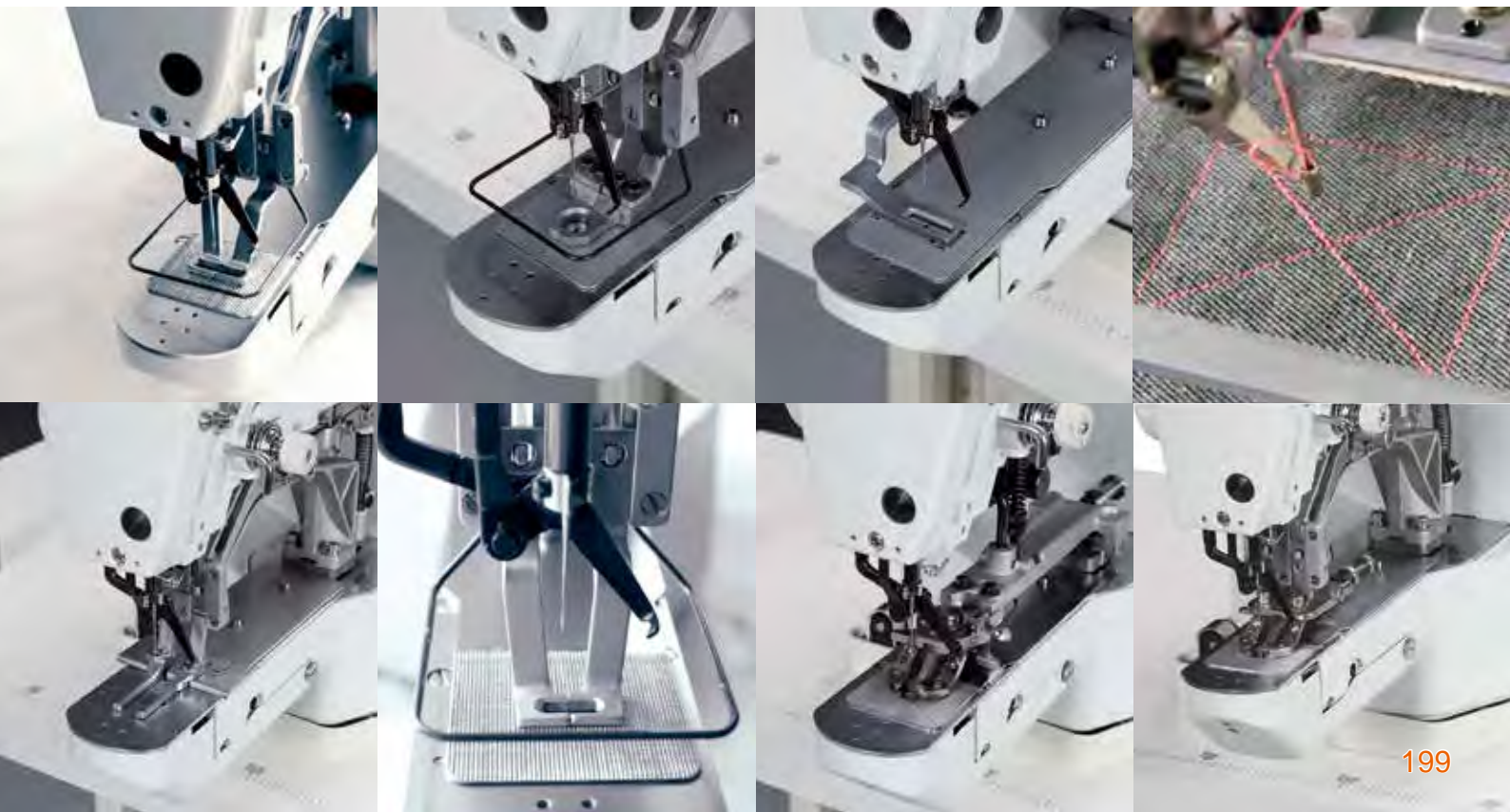

無油機構設計

採用DLC 針棒·挑線機構軸承設計·以固態油脂潤滑·有效防止面料油污問題

Oil-free Mechanism Design

With DLC needle bar, thread take-up lever's bearing design, and grease lubrication, it avoids the problem of oil stain.

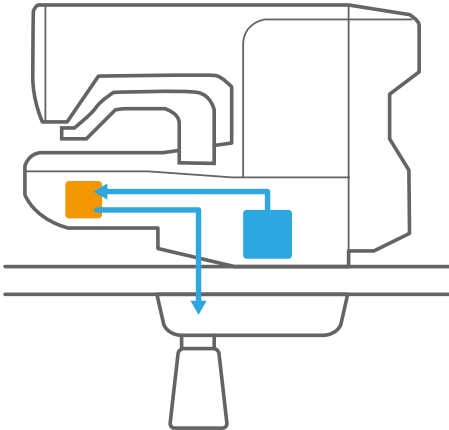
**雙踏板模式**

支援雙踏板操作模式·縫製特殊產品時·定位更容易

Dural Pedal Mode

Support double pedal mode for special sewing operation. It makes the material positioning easier.

**均勻的大壓腳壓力**

可對大壓腳角度進行調節·使得四周壓力均衡·確保縫製物穩定

Dural Pedal Mode

Support double pedal mode for special sewing operation. It makes the material positioning easier.

**操作面板內建USB埠**

以USB 記憶體進行圖形資料儲存·方便快速

Control Panel with Built-in USB port

It is easy and convenient for Pattern input by USB memory

**適用範圍大**

中厚料規格·可以改進挑線行程·提高線跡穩定度·擴大厚料縫製性能

Wider Range of Sewing Application

For heavy material, with thread take-up lever's stroke changing, it makes the stitches stable and upgrades the sewing performance.

**短線頭設計**

改進切線結構·在針孔最近點線·使餘線長度變短·減少修線工作

Short Thread End Design

Improving the thread trimming mechanism to cut the thread at the nearest spot from the needle. It shortens the thread end and reduces the finishing job.

**BT630A****均勻的大壓腳壓力**

可對大壓腳角度進行調節·使得四周壓力均衡·確保縫製物穩定

Dural Pedal Mode

Support double pedal mode for special sewing operation. It makes the material positioning easier.

均勻穩定的收線

由於間歇壓腳提升量可以改變·當裁片厚度變化時·不會產生壓力過大或不足的問題·確保在低張力下仍可穩定收線

Consistent and Stable Thread Tightness

As the stepping presser foot's height can be changed, no problem of excessive or insufficient pressure with the sewing material thickness changing, it makes the stable thread tightening.



BT430A-01 / 02

01 01 標準
Standard

02 厚料
Heavy material



BT430A-03

帽眼
Radial tacking



BT430A-05

褲耳
Belt loop



BT430A-06

鬆緊帶拼接
Elastic Band Joining



BT430A-07

針織
Knits material



BT438A

釘扣
Button sewing



BT530A

兩用型 套結/釘扣
2-in-1 Bartacking/ Button sewing

出廠時為套結機，釘扣套件
附在配件盒中，用戶可以操
作面板切換車縫模式

Bartacking is the standard
setting, while the button
sewing kit is included.
Customer can change the
sewing mode by control
panel.



BT630A

小型花樣機(8X6)
Small Area Pattern Sewing (8X6)



代號 Code	BT430A						BT438A	BT530A	BT630A
	01	02	03	05	06	07			
用途 Application	標準 Standard	厚料 Heavy material	帽眼 Radial tacking	褲耳 Belt loop	鬆緊帶拼接 Elastic Band Joining	針織 Knits material	釘扣 Button sewing	兩用型 套結 / 釘扣 2-in-1 Bartacking/ Button sewing	小型花樣機 Small Pattern Sewing
最高縫製速度 Max. Sewing Speed	3200 SPM						2700 SPM		3000 SPM
縫製區域 (X x Y) Sewing area (X x Y)	40X30	40X30	15X15	40X30	9X40	40X30	6.4X6.4	40X30	80X60
鈕扣尺寸 Button Size	間歇性送布 (脈衝馬達驅動) Intermittent Feeding (Pulse motor drive mode)						8~30mm		
送布方式 Feeding									
針距 Stitch length	0.05~12.7 mm								
最大針數 Max. stitch	5000 針 / 圖形 5000 stitch / pattern								
抬壓腳 Presser foot lifter	脈衝馬達驅動 Pulse motor drives								
壓腳 / 鈕夾上升量 Height of Presser foot/ Button clamp Lifting	Max. 17mm						Max. 13mm	Max. 17mm Max. 13mm	Max. 17mm
旋梭 Hook	半旋轉標準旋梭 Standard Shuttle hook								
外部資料儲存 External Data storage	經由 USB 埠 Inputted by USB Port								
循環縫 Cycle program	最多30 組, 每組上限50個步驟 Max. 30 sets, each set includes Max. 50 steps.								
記憶容量 Memory Capacity	內建 89種圖形, 最多可追加 512種圖形 / 500,000針 Built-in 89 patterns, Max. 512 patterns / Max. 500,000 stitches can be added.								
馬達 Motor	直驅式 AC 伺服馬達 550W Direct-drive AC Servo Motor 550W								
電源 Power	單相 220V Single Phase 220V								
重量 Weight	機頭: 約 57 kg, 操作面板: 約 0.4 kg, 控制箱: 約 9 kg Machine Head: about 57 kg, Operation Panel: about 0.4 kg, Contro Box: about 9 kg								



先進電子技術精確控制，生產效率與縫紉品質得到高水準提升

Accurate sewing based on sewing data



BH9820 SERIES

電子圓頭鎖眼機

Direct-drive Programmable
Electronic Eyelet Button Holer

BH-9820-00

BH-9820-01

BH-9820-02

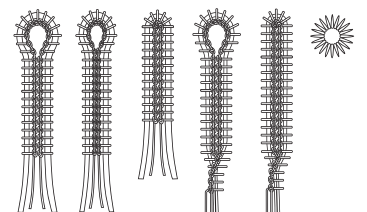

1 改良氣缸

優化改進的可攜式氣管介面，隨插即用，用戶外接氣源更簡便

Improved cylinder

Improved pipe port to make connection much easier.

**2 特殊工藝加工處理的齒輪和凸輪，大幅度降低了機器噪音及震動，經過科學的實驗測試，噪音比歷史資料降低了8-10個分貝，操作工的舒適度大大提升**

Special process processing of gears and cams, a significant reduction in the machine noise and vibration, after a scientific experimental test, the noise than the historical data reduced by 8-10db, the operator's comfort greatly improved.

**3 精確調整簡單易行**

切刀間隔和切刀位置補正等精確調整可在液晶顯示幕的操作盤上進行。專案以圖示顯示，操作人員無需閱讀也可直觀地進行操作

Easy adjustment

The position and adjustment of cutting knife can be adjusted by operate panel. All these adjustments will be showing in the operate panel in image.

4 提高了圖案的精確性

採用了伺服控制的送布裝置提高了剛性，因此可縫製出高精度圖案，即便高速縫紉或縫製重物時，也不會產生電子縫紉機常有的失調偏位。伺服控制還免去了初始位置的檢測

Making the accurate pattern

The machine controlled by servo system, it makes the patterns accurate even in high speed stitching. servo control system avoid the initial position checking.

**5 減少跳針**

優化彎針形狀，挑線量和其他零件。無論使用何種類型的線，由於線張力的改變而引起的跳針和針腳不夠緊密的情況都減少了，使縫紉能力得到擴張

Reduce skip stitch

Improved the looper and thread take-up, machine can stitch different fabric with different thread.

縫紉能力擴展圖

Sewing capacity expansion picture

(面線張力 / Tension force of stream thread)

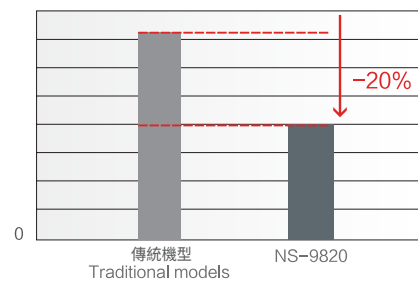

3.0mm寬度之字縫，縫紉後裁剪

2塊聚酯纖維(其中一塊的一側有夾層)

紡線：# 40

底線張力：30g

縫紉速度：2,500rpm

3.0mm-wide zigzag sewing, after-sewing cutting.

2 pieces of polyester serge

(one side of one piece has a layer).

Span thread：# 40

Tension force of end thread：30g

Sewing speed：2,500rpm

6 短切面線及底線剪線器的特殊規格 (-02)

-02 規格中，單機支援較大範圍的應用，從休閒褲的平頭扣眼加固縫到牛仔褲的流線扣眼加固縫。該規格的縫製長度範圍為：18-26 mm

special specification of thread trimmer for -02 model

The machine model -02 can stitch big size pattern for both casual pants and jeans.the length of eyelet button hole can be 18-26mm.

7 以圖示和文字顯示便於理解

The display of icons and characters makes it easy to understand

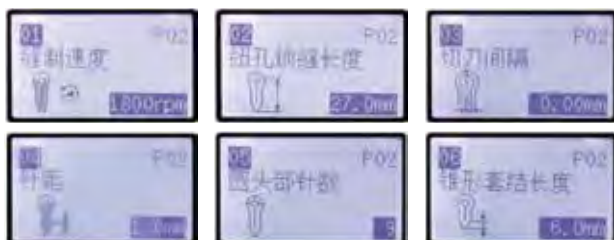

多語言顯示 Multi-language display



功能拓展

FUNCTION EXTENSION



8 操作簡單的操作盤

NS-9820 帶有液晶顯示幕(LCD)，並以圖示和文字顯示，設置或查看圖案以及更改縫製模式時，便於理解並易於操作

Easy operation

NS-9820 has liquid crystal display (LCD), supported by icon and character display. When setting or checking pictures and changing sewing mode, it is easy to understand and operate.



應用實例

APPLICATION EXAMPLE

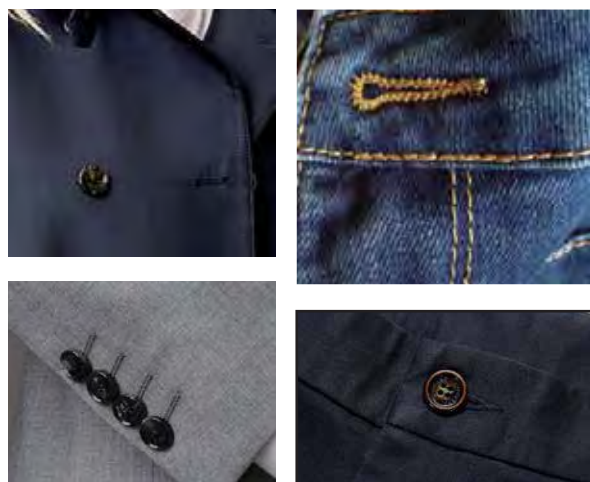

規格 Specification	BH-9820-00	BH-9820-01	BH-9820-02
面線剪線裝置 Needle thread trimmer	長線剪切 Long thread trim	長線剪切 Long thread trim	短線剪切 Short thread trim
底線剪線裝置 Bobbin thread trimmer	無 None	長線剪切 Long thread trim	短線剪切 Short thread trim
主要用途 Main applications	女裝 Suit-dress	男裝、休閒裝 Men's clothing, casual clothing	牛仔褲、褲裝 Jeans trousers, trousers
其他用途 Other applications	男裝、休閒裝、牛仔褲、褲裝 Men's clothing, casual clothing, jeans trousers, trousers	女裝、牛仔褲、褲裝 Suit-dress, jeans trousers, trousers	—
功能 Function	剪線裝置僅剪切面線。 可縫紉最長為50mm的扣眼。 Only trim the needle thread. The max. Length of button hole is 50mm;	剪線裝置將較長地剪切所有線頭。 在縫紉持續過程中可在更長距離內安全把握線尾。 Trimming both needle thread and bobbin thread	剪線裝置將較短地剪切線頭。 這樣可省去動手。 Trimming both needle thread and bobbin thread. No need second trim
縫製形狀 Sewing shape			
縫紉長度 Sewing length	圓頭鎖眼 8-50mm 直形鈕孔 8-50mm Round-head eyehole 8-50mm Straight button hole 8-50mm	圓頭鎖眼 8-42mm 直形鈕孔 5-42mm Round-head eyehole 8-42mm Straight button hole 5-42mm	22-30mm* 14-22mm* 18-26mm* 26-34mm* 34-42mm*
壓腳長度(標準) Press foot length (standard)	30mm		30/26mm
刀墊長度(標準) Length of hammer (standard)	22mm		24/20mm
刀墊長度(附件) Length of hammer (accessory)	30mm		28/24mm
縫紉速度 Sewing speed	1000-2500rpm		
針碼 Needle code	0.5-2.0mm		
之字縫寬度 Zigzag sewing width	1.5-5.0mm (在機械條件下最寬為4.0mm之字縫寬度補償最多為5.0) 1.5-5.0mm (In mechanical conditions, it is 4.0mm wide at most and the zigzag sewing width is 5.0 At most.)		
之字縫寬度(出廠設置) Zigzag sewing width (factory setting)	2.5mm		3mm
流線加固縫長度 Length of stream thread	0-20mm		
壓腳高度 Height of work clamp	標準高度為12mm(最高可達16mm) Standard height is 12mm (may reach 16mm at highest)		16mm
啟動方式 Start-off mode	雙踏板開關 Double pedal switch		
送布裝置 Fabric feeding device	三個脈衝馬達的間歇送布 (x,y,θ) Intermittent cloth-sending of 3 pulse motors (x,y,θ)		
機針*4 Machine needle 4	DOx558 Nm80 - Nm120		
安全設備 Safe setting	若有問題發生，有緊急停止功能和由安全電路驅動的內置自動停止設備 If there are any problems, the inner setting with urgent stop function and driven by safe circuit will automatically stop the machine		
上軸馬達 Upper shaft motor	AC伺服馬達550W AC-servo motor 550W		
空氣壓力 Air pressure	主調整器：0.5Mpa; 錘壓調整器：0.4Mpa Main regulator : 0.5Mpa; Hammer-pressure regulator : 0.4Mpa		
空氣消耗量 Air consumption volume	43.2升/分鐘(8周/分鐘) 43.2 liter/minute (8 cycles/minute)		
電源 Power supply	單相 100V / 200V, 三相 200V / 220V / 380V / 400V, 400VA Single phase 100V / 200V, Three phases 200V / 220V / 380V / 400V, 400VA		
重量 Weight	機頭：≈ 120kg / 操作盤：≈ 0.6kg / 控制箱：14.2-16.2kg Machine head: ≈ 120kg / Operation board : ≈ 0.6kg / Control box : 14.2-16.2kg		

BUTTONHOLING MACHINE

LBHS

-

179 □

□

機種別
Model

高速電子平頭鎖眼機
Computer-controlled,
High-speed, Lockstitch
Buttonholing Machine

壓腳規格
Work clamp foot

0	5mm X 35mm 標準 / Standard
2	5mm X 35mm 針織布專用 / For Knit
5	5mm X 120mm 加長型 / Long type

適用布料
Sewing Material

S	標準規格 Extra small, Standard
K	針織布規格 For Knit



優越的性能

循環縫製 · 連續縫製

- 循環縫製
可以登錄20種的程式，每個程式最大可以儲存15個花樣。
- 連續縫製
多個花樣可以在不抬起壓腳的情況下連續進行縫製。能夠登錄20種程式，每個程式可以最大儲存6個花樣。
(必須交換選購件的零件)

Excellent Performance

Cycle sewing · Continuous sewing

- Cycle Sewing
20 different programs can be registered, and as many as 15 different patterns can be stored in one program.
- Continuous Sewing
The machine is able to continuously sew many different patterns without requiring the work clamp foot to be lifted. As many as 20 programs can be registered, and 6 different patterns can be stored in one program. (Related parts need to be exchanged for optional ones.)

高速，乾淨

- 最快縫製速度4,200sti/min · 一般速度3,600sti/min
- 通過先進的無油技術 · 除旋梭部分以外實現無供油 · 消除因為油對產品產生的污染

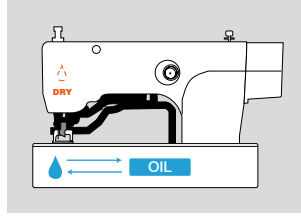

High Speed and Clean

- Max. 4,200sti/min, Normal 3,600sti/minsubstantially decreased.
- Advanced dry-head technology, no lubrication is required except for the hook section. This eliminates oil stains on the sewing product.

所有的驅動裝置實現電子控制

- 送布、送針、上切線、下切線、切布刀、壓腳抬升裝置等全部實現電子化控制
- 所有的調整數值數位化 · 通過操作面板可以進行設定儲存

All drive mechanism is electronically

- An electronic control feature has been adopted for the material feed mechanism, needle rocking mechanism, needle thread trimming mechanism, bobbin thread trimming mechanism, cloth cutting knife mechanism and presser bar lifting mechanism.,
- All adjustment values are entered as data. They can be set or stored in the memory on the operation panel.

多種踏板功能

- 標準配置了脈衝馬達式自動抬壓腳裝置 · 減輕操作工的疲勞 · 1次踏板 / 2次踏板的切換 · 方便定位可以中途停止
- 壓腳抬升高度可以任意設定 · 帶有逆回轉針功能 · 壓腳最大可以抬升17mm

Many functions of the pedal

- The machine is provided as standard with auto-lifter driven by a stepping motor. This helps reduce the operator's fatigue. As for the pedal, 1-pedal and 2-pedal modes can both be changed over and the intermediate stop, which facilitates positioning of the sewing product, can be specified.
- The work clamp foot lift can be set as desired. The reverse-rotation needle-up function offers a maximum work clamp foot lift of 17mm.

多種踏板功能

EXPLANATION OF PEDAL MOTION

踏板動作 Pedal motion	踏板樣式 Pedal type		
	2踏板 2-pedal	1踏板(中間位置無) 1-pedal (without intermediate position)	1踏板(中間位置有) 1-pedal (with intermediate position)
初期位置 Initial position	②中間位置 ②Intermediate position	①最高位置 ①Maximum position	①最高位置 ①Maximum position
縫製品設置 Setting of sewing product	根據左踏板踏入量壓腳抬升、左踏板歸位下降 →③縫製位置 Presser goes up as high as pedal toe to down amount of the left side pedal. Presser comes down when the left side pedal is depressed. →③Sewing position	右踏板1段 →③縫製位置 The first step of the right side pedal →③Sewing position	右踏板1段 →②中間位置 ↓ 右踏板2段 →③縫製位置 The first step of the right side pedal →③Intermediate position ↓ The second step of the right side pedal →③Sewing position
縫製開始 Start of sewing	右踏板踏入 The right side pedal is depressed	右踏板2段 The second step of the right side pedal	右踏板3段 The third step of the right side pedal
縫製結束 End of sewing	②到中間位置為止 壓腳抬升 ②Presser automatically goes up to intermediate position	①最高位置為止 壓腳抬升 ①Presser automatically goes up to maximum position	①最高位置為止 壓腳抬升 ①Presser automatically goes up to maximum position
壓腳位置 Work clamp position			



簡單切換縫製的設定

Sewing settings can be easily changed



(三角縫與平縫的切換，必須要變更梭殼的穿線及底線的張力。)

(For a changeover between purl stitch and whip stitch, threading of bobbin, as well as the bobbin thread tension need to be changed.)



二重縫在套結部分是交叉的，因為在平行部分也能進行二重縫，所以套結部分的線跡會變得柔軟。

循環一周和循環兩周的縫製幅度可以進行調整
(need to be changed.)

• For double stitching, the bartacking section is skipped and only the parallel

sections are sewn twice. This prevents any excessively tight finishes in the bartacking section of the buttonhole.

• First- and second-round stitches can be sewn using different stitch widths.

選配

OPTIONS

切刀寬幅 Knife size	切布切刀 Cloth cutting knife		切布刀·壓腳 Cloth cutting knife, Work clamp				壓腳 Work clamp foot					
					擺幅5mm用 For stitch width 5mm		擺幅6mm用 For stitch width 6mm					
	型號 Part No.	Mark	LBHS-1790S (標準) (standard)	LBHS-1792K (針織用) (for knits)	LBHS-1795A (標準) (standard)	LBHS-1790S (標準) (standard)	編號 (類型) Part No. <Type>	1790 S	1792 K	編號 Part No.	1790 S	
6.4mm (1/4")	BL724AJK	A	P570CJK (6.4~19.1mm) <1> (4x25mm)	P576JK (6.4~19.1mm) <1> (4x25mm)	P575AJK (5x120mm)	P573JK (6.4~31.8mm) <3> (6x41mm)	P570CJK-A <1>	◎	◎	P574JK	◎	
9.5mm (3/8")	BL724BJK	△										B
11.1mm (7/16")	BL724CJK											C
12.7mm (1/2")	BL724DJK	◎										D
14.3mm (9/16")	BL724EJK											E
15.9mm (5/8")	BL724FJK	△										F
17.5mm (11/16")	BL724GJK											G
19.1mm (3/4")	BL724HJK											H
22.2mm (7/8")	BL724IJK		I	◎	P572JK (6.4~25.4mm) <2> (5x35mm)	P572JK-A <2>		◎				
25.4mm (1")	BL724JJK	△	J									
31.8mm (1-1/4")	BL724KJK		K	P574CJK (6.4~31.8mm) <3> (5x41mm)	P577JK (6.4~31.8mm) <3> (5x41mm)							

◎本體裝 △附屬品 (LBH-1790AS用) ◎Factory installed on machine △Supplied as an accessory (For LBH-1790S)

針板

THROAT PLATE

擺幅 For needle throwing width				
	標準 (S) Standard (S)		針織用 (選購) For Knits (K)	
5mm	E201AJK (S5: 1.4×6.2mm)	◎	E201BJK (1.2×6.2mm)	
6mm	E202AJK (S6: 1.4×7.4mm)		E202BJK (1.2×7.4mm)	◎

名稱 Designation	型號 Part No.	品名 Description
長壓腳 (最大 120mm 車縫長度) Work clamp (For sewing length of 70 mm, 120mm)	P574JK	Work clamp foot 120 (asm.)
	P575AJK	Work clamp 120
	BF750JK	Work clamp arm 120
	BF749JK	Cloth feeding plate 120
	BF747JK	Close cam 120
	BF748	Lifting plate 120
	SM539 (2 pcs.)	Screws
	P567JK-2 (2 pcs.)	Screws

規格

SPECIFICATIONS

縫製速度 Sewing speed	Max. 4,200sti/min, Normal 3,600sti/min
針杆行程 Needle bar stroke	34.6mm
切布刀尺寸 Size of cloth cutting knife	6.4 ~ 31.8mm (1/4" ~ 1-1/4")
套結寬幅 Bartacking width	Max. 5.0mm
鎖眼長度 Buttonhole length	最大41mm (選購件: 120mm) Max. 41mm (optional: 120mm) LBHS-1795: 120mm
針振動分解能 Precision of needle throwing mechanism	0.05mm
面線張力 Needle thread tension	電子夾線器 (電子線張力調整器) Active tension (electronic thread tension control system)
針數 Number of stitches	鎖眼尺寸・根據縫製自動計算 Automatically computed from the size of the buttonhole and stitch pitch
使用機針 Needle	DP×5 (#11J) #11J ~ #14J
使用旋梭 Hook	DP類型全回轉旋梭 DP type, full-rotary hook
壓腳抬升量 Lift of the work clamp	14mm (逆轉針上升時17mm) (17mm by the reverse-rotation needle-up function)
自動抬壓腳 Auto-lifter	標準裝備 (脈衝馬達式) Provided as standard (stepping motor type)
針擺動驅動方式 Needle throwing system	脈衝馬達驅動 Stepping motor
送布驅動方式 Cloth feeding system	脈衝馬達間隔送布 Intermittent feed by stepping motor
切布刀驅動方式 Cloth cutting knife system	雙向電磁鐵 By double-acting solenoid
標準花樣數 Number of standard patterns	30 patterns
可儲存花樣數 Number of patterns that can be input	Max. 99 patterns
底線捲線裝置 Bobbin thread winder	機頭內建式 Built-in the machine head
頭部驅動裝置 Machine head drive system	小型AC伺服馬達 (直接驅動方式) Compact AC servomotor (direct-drive system)
電源/耗電量 Power requirement/ Power consumption	單相220V, 230V, 240V, 三相200 ~ 240V/ 600VA Single-phase 220V, 230V, 240V · 3-phase 200 ~ 240V/600VA
供油方式 Lubrication	僅旋梭部微量供油 Only the hook section needs a minute-quantity lubrication.
使用油 Lubricating oil	旋梭部: New Defrix Oil No.1 (ISO VG7相當) Hook: New Defrix Oil No.1 (equivalent to ISO VG7)
重量 Total weight	112kg

STANDARD SEWING PATTERN LIST

- | | | | | | | | | | | | |
|----------|-------------------|----------|------------------|----------|----------------------------|----------|--------------------|----------|---|----------|-----------------------|
| 1 | 角型
Square Type | 2 | 圓型
Round Type | 3 | 輻射角型
Radial Square Type | 4 | 輻射型
Radial Type | 5 | 輻射直線加固型
Radial Straight Bar-tacking Type | 6 | 半月型
Semilunar Type |
|----------|-------------------|----------|------------------|----------|----------------------------|----------|--------------------|----------|---|----------|-----------------------|

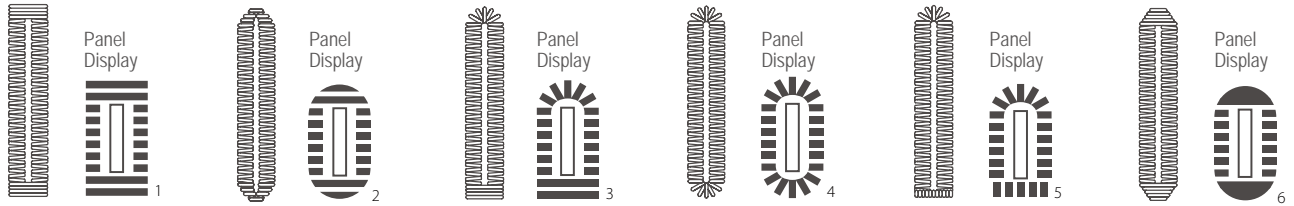

- | | | | | | | | | | | | |
|----------|--------------------------|----------|--|----------|------------------------------|-----------|-------------------------------|-----------|---|-----------|--|
| 7 | 圓角型
Round Square Type | 8 | 輻射流動加固型
Radial Taper Bar-tacking Type | 9 | 圓頭釘眼角型
Eyelet Square Type | 10 | 圓頭釘眼輻射型
Eyelet Radial Type | 11 | 圓頭釘眼直線加固型
Eyelet Straight Bar-tacking Type | 12 | 圓頭釘眼流動加固型
Eyelet Taper Bar-tacking Type |
|----------|--------------------------|----------|--|----------|------------------------------|-----------|-------------------------------|-----------|---|-----------|--|

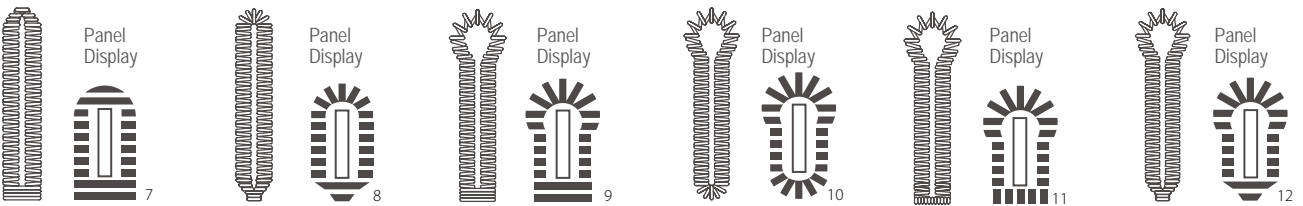

- | | | | | | | | | | | | |
|-----------|------------------------------|-----------|--|-----------|---|-----------|----------------------------------|-----------|-----------------------------|-----------|----------------------------|
| 13 | 直線角型
Square Straight Type | 14 | 半月直線加固型
Semilunar Straight Bar-tacking Type | 15 | 半月流動加固型
Semilunar Taper Bar-tacking Type | 16 | 圓頭釘眼半月型
Eyelet Semilunar Type | 17 | 圓頭釘眼圓型
Eyelet Round Type | 18 | 角輻射型
Square Radial Type |
|-----------|------------------------------|-----------|--|-----------|---|-----------|----------------------------------|-----------|-----------------------------|-----------|----------------------------|

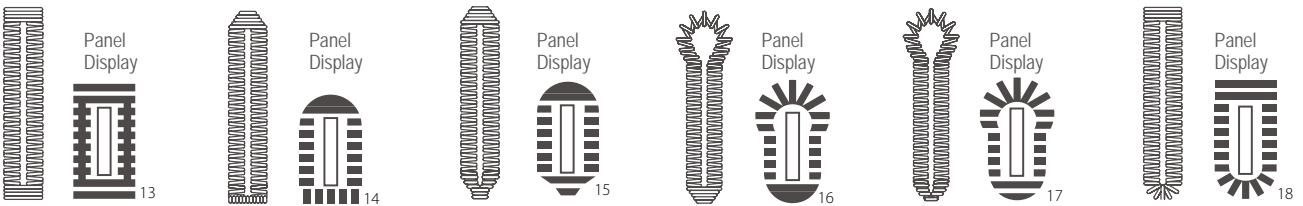

- | | | | | | | | | | | | |
|-----------|-------------------------------|-----------|--------------------------|-----------|--|-----------|---|-----------|--------------------------------|-----------|---------------------------|
| 19 | 角半月型
Square Semilunar Type | 20 | 角圓型
Square Round Type | 21 | 角直線加固型
Square Straight Bar-tacking Type | 22 | 角流動加固型
Square Taper Bar-tacking Type | 23 | 輻射半月型
Radial Semilunar Type | 24 | 輻射圓型
Radial Round Type |
|-----------|-------------------------------|-----------|--------------------------|-----------|--|-----------|---|-----------|--------------------------------|-----------|---------------------------|

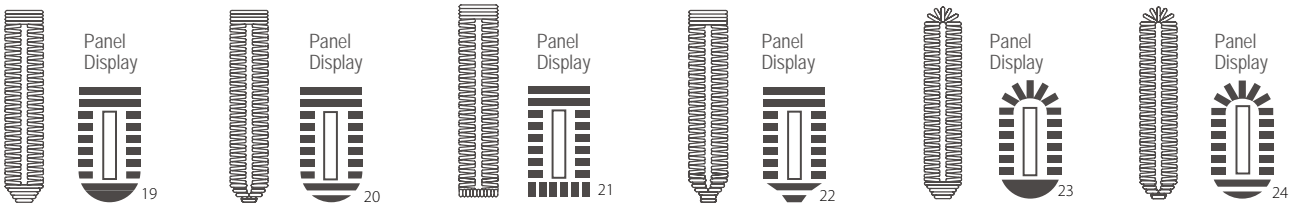

- | | | | | | | | | | | | |
|-----------|--------------------------------|-----------|------------------------------|-----------|--------------------|-----------|---------------------------------|-----------|--------------------------------|-----------|-----------------------------------|
| 25 | 半月輻射型
Semilunar Radial Type | 26 | 半月圓型
Semilunar Round Type | 27 | 加固縫
Bar-tacking | 28 | 加固右切斷
Bar-tacking, Right Cut | 29 | 加固左切斷
Bar-tacking, Left Cut | 30 | 加固中央切斷
Bar-tacking, Center Cut |
|-----------|--------------------------------|-----------|------------------------------|-----------|--------------------|-----------|---------------------------------|-----------|--------------------------------|-----------|-----------------------------------|

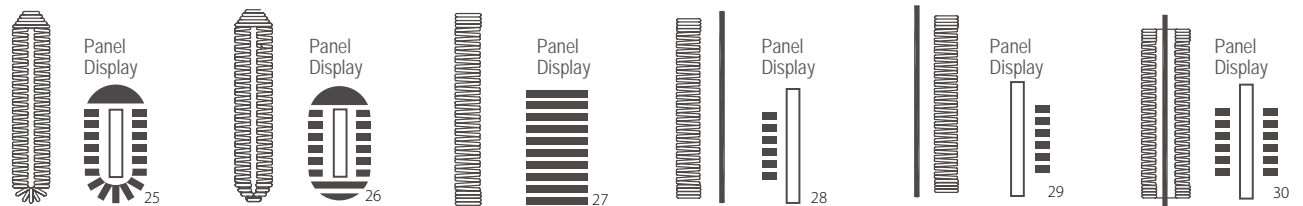

BUTTON SEWING BARTACKING MACHINE

Computer-controlled, High-speed, Lockstitch, Bartacking Machine

Computer-controlled, High-speed, Lockstitch, Button Sewing Machine

LKS - 190 □ AN - S S - □

機種別 Model
0 套結縫紉 Bartacking
2 釘褲耳 Belt-loop attaching
3 釘釦 Button sewing

電控系統 Control System
AN 原有系統 Original System
P 一體機 Mechatronic

壓腳 Work clamp foot
S 標準 Standard
H 厚料 Heavy material

縫製區分 Application
S 標準 Standard
H 厚料 Heavy material
F 內衣 Foundation

釦扣配件 Button sewing Attachment
301 極小扣、小扣 Extra small, small button
302 中扣 Medium button
ABF 自動扣 Automatic Button Feeding

LKS-1900AN



LKS-1900P



特點 / FEATURE

高效地生產性能

現了高速的縫製速度3,200rpm，通過高速的性能，能快速啟動和終止縫製，通過高速的切線速度以及自動抬壓腳操作，大幅度縮短了套筒循環時間。

優質的縫製品質

配備面線夾線機構。它可防止起縫時的鬆線，以及布料反面的鳥巢現象，還消除了面線被污染的情況。通過進一步改進切線機構，使切線後留在布料反面的線殘量變短。



廣闊的縫製範圍和多樣化地縫製花樣

具備了縱30mm × 橫40mm 的縫製範圍，可對應多樣化地套結形狀，包括一般套結形狀和半月套結，圓型套結及菊花孔鎖眼等50多個種類的縫製花樣。在LK-1900，LK-1900AN上使用的資料(EP-ROM, EEP-ROM)也能進行縫製使用。

消除了油污

通過採用先進的乾機頭化技術，面部（針杆部・挑線杆部）實現了無機油化。擺梭部是通過油箱來提供微量的乾淨的機油。

標準裝備了電子夾線器

可在操作盤上設定能對應各種縫製條件（線・布料・縫製速度等）的面線張力，同時此資料也可保存或者再使用。可分別設定起縫・暗縫・曲折縫以及縫製結束時（固定縫）各部位的面線張力。如果使用了操作控制盤IP-420B，可設定每一針的面線張力。它改善了高低段部以及縫製方向的收線不良，提高了縫製品質。



電子夾線器
Active tension

標準裝備了新型的脈衝馬達式自動抬壓腳機構

可以切換從1段行程到2段行程，使車縫操作容易手持定位。2段行程可通過操作控制盤來設定中間停止的高度。壓腳上升量通過與僅轉抬針機能並用，最大可達到17mm。

Higher productivity

The machine realizes high speed 3,200rpm. In addition to the high speed sewing performance, cycle time can be substantially decreased.

Excellent seam quality

With needle thread nipper, which prevents thread slipping off from the needle hole at the beginning of sewing, and bird-nest problem on the bottom side, and also oil stain problem. For the advanced thread trimming mechanism, the remained thread-end can be shortened.

Wider sewing area and many different sewing patterns

The With 30mm X 40mm (L x W) sewing area, the machine can sew 50 patterns of bartacks, including common shapes, half-moon, round, radical tacking. The machine can sew by the same data of LK-1900 and LK-1900AN (EP-ROM, EEP-ROM).

Oil stains are eliminated

With dry-head technology, the frame (needle bar, thread take-up) no longer requires oil-lubrication. Just a small quantity of clean oil is supplied from the oil tank to the shuttle hook.

Electronic thread tension controller is standard equipped.

With active tension mechanism, it can set a needle thread tension that matches various sewing conditions (such as thread, material, sewing speed...) on the operation panel, store the data in memory or reuse. The needle thread tension can be separated according to stitching type or portion of a seam, such as the beginning part, base part, zigzag part and ending part (fastening stitch). With operation panel IP-410B, the tension can be set on a stitch-by-stitch basis. This eliminates undesired thread tension variations at a multi-layered part of material or with sewing direction, which upgrades seam quality.

Stepping motor type auto-lifter is standard equipped

Auto-lifter can be set as one-step stroke or double-step stroke, which offers easier sewing material handling. For the double-step stroke, an intermediate stopping height can be set on the operation panel. The presser foot lifter can be set to 17mm Max. by using the reverse-rotation needle-up function in combination with the auto-lifter mechanism.

優越的操作性能

通過小型AC伺服馬達直接連結的直接驅動式機頭(無皮帶)·實現了優越的應答性能及精確的剎停精度。即使是在高速運轉下也能創造出低振動、低噪音的舒適的工作環境。在機頭部設置了手輪·能更容易確認針的落針點。

可在起縫點處進行調整

起縫點可向X、Y方向移動。配合壓腳形狀可以調整縫製花樣的位置。

Excellent workability and operability

The direct-drive head (without belt), which is driven by compact AC servo motor, realizes outstanding responsiveness and improved stop accuracy, which provides a comfortable working condition with low vibration and noise. The arm section is equipped with a hand wheel. Operators can visually check the needle entry points.

The sewing starting point can be corrected.

The sewing starting point can be shifted in X/Y direction. This enables the correction of a sewing pattern in accordance with the presser foot configuration.

LKS-1902AN

特點 / FEATURE

可通過單鍵操作來選擇縫製花樣

標準裝備了6個種類的線套結花樣。由於可分別使用最適合褲帶環寬度的針數以及縫製尺寸·因此可簡便的變更縫製尺寸。

重視操作性的機頭設計

大彎曲的送布台(壓腳臂)更易於面料的安放。此外·寬闊的機台和細長型的機床形狀等這些頭部設計·即使是揮動布料或者連續的工序都能發揮優越的操作性·提高了褲帶環縫的生產效率。



The sewing pattern can be selected by single-key operation

With 6 patterns of linear bartacks. Since the sewing size can be easily changed, the optimal number of stitches and sewing size can be speedily selected according to the belt-loop width.

Operability-oriented design

With its broadly curved feed bracket (presser arm), the machine provides easy placing of sewing material. The slim shape bed and head design makes free space under the arm demonstrates greater operability in handling sewing materials, which increases production efficiency.

LKS-1903AN

特點 / FEATURE

高效的生產性能，多種的縫製花樣

最快縫製速度2,700sti/min·能快速地啟動和結束縫製·標準配備了50種縫製花樣·能簡單地進行切換·方便應對多種縫製花樣。任選配ABF自動送扣裝置·可以得到最高生產效率。



Higher productivity, many sewing patterns.

The machine achieves sewing speed as 2,700rpm Max. with quick starting and stopping. Providing 50 sewing patterns, which changeover is easy to be set. With optionally equipping ABF auto-button feeder, LKS-1903AN can reach the highest production efficiency.



• ABF

規格 SPECIFICATIONS

機種名 Model name	套結 Bartacking			釘褲耳 Belt-loop Attaching		釘扣 Button Sewing
	LKS-1900AN-SS	LKS-1900AN-HS	LKS-1900AN-FS	LKS-1902AN-SS	LKS-1902AN-HS	LKS-1903AN-SS
規格 Application	標準 Standard	厚料 For heavy-weight materials	內衣 For foundation	標準 Standard	厚料 For heavy-weight materials	標準 Standard
最高縫製速度 Max. sewing speed	3,200sti/min*			3,000sti/min*		2,700sti/min*
可縫尺寸 Sewing area	縱30mmX橫40mm 30mm(L)X40mm(W)					鈕扣尺寸: 圓型平扣 Φ8-Φ32mm 標準(Φ8-Φ20mm) Button size: Round-shaped, flat button Size: Φ8-Φ32mm (standard Φ8-Φ20mm)
縫跡長度 Stitch length	0.1~10mm(0.1mm 單位) 0.1~10mm(0.1mm step)					
針杆行程 Needle bar stroke	41.2mm					45.7mm
壓腳上升量 Lift of the work clamp foot	標準14mm(反轉針上升時17mm) Standard 14mm(17mm when the reverse-rotation needle-up function)					最大13mm MAX. 13mm
自動抬壓腳裝置 Auto-lifter	標準裝備(脈衝馬達) Provided as standard (stepping motor type)					
面線張力 Needle thread tension	電子夾線器(電子夾線機構) Active tension (electronic thread tension control system)					
機針 Needle	DPX5(#14)	DPX17(#21)	DPX5(#11)	DPX5(#14)	DPX17(#21)	DPX17(#14)
旋梭 Hook	半旋轉標示旋梭 standard shuttle hook					
記憶容量 Number of stitches that can be stored in memory	最多20,000針 Max. 20,000 stitches					
標準花樣數 Number of standard patterns	50個花樣 50 patterns			17,18(19,20,21,22*)出廠時為「禁止 呼叫顯示」 17,18(19,20,21,22*)*This device has been factory-set to "invoking prohibited" status at the time of delivery.		50個花樣 50 patterns
可記憶數據 Number of data that can be input	200個個花樣(最多可追加至150個花樣縫製數據) 200 patterns (for up to 150 patterns, sewing data can be added.)					
擴大、縮小機能 Enlarging/Reducing facility	20~200%(1%單位)、縫製長度增減方式 20~200%(1% step), Pattern enlargement/reduction can be done by increasing/ decreasing the stitch length					
記憶媒體 Memory media	EEP-ROM · EP-ROM					
底線計數 Bobbin thread counter	標準裝備(上增、下減方式) Provided as standard(up/down method)					
加油方式 Lubrication	旋梭部；微量加油 Hook: minute-quantity lubrication					
機油 Lubricating oil	白礦油#32 ISO VG32					
機器馬達 Sewing machine motor	小型AC伺服馬達(直驅式) Compact AC servo motor(direct-drive system)					
消費電力 Power consumption	450VA					530VA
重量 Weight	頭部(搭載馬達)42kg · 電子裝置16.5kg Machine head (include motor)42kg · Control box 16.5kg					機頭 (搭載馬達)47.3Kg · 電控箱11.3Kg) Machine head (include moto)47.3kg · Control box 11.3kg

*sti/min是Stitches per Minute (針/分)的省略

*快閃記憶體卡(TM)請使用符合CFA規格產品

*快閃記憶體卡(TM)是美國Sandisk商標

*sti/min stands for "Stitches per Minute"

*Compact Flash TM or CFA specification compatible media.

*Compact Flash TM is a registered trademark of SanDisk Corporation, U.S.A.

*使用專用壓腳時，請確認縫製圖案的形狀。萬一，壓腳突出縫製圖案，縫製途中機針就有碰到壓腳，發生斷針的危險。

*In case of using an exclusive work clamp foot, make sure of the shape of the sewing pattern. If the sewing pattern extends outside the work clamp foot, the needle interferes with the work clamp foot during sewing, resulting in the danger of the needle breakage or the like.

NO.	1	2	3	4
壓腳 Work clamp foot	P801JK-A(組件) P801JK-A(asm.)		P802JK-A(組件) P802JK-A(asm.)	
壓腳下板 Feed plate	D801JK 有齒牙 With knurl	D811JK 無齒牙 Without knurl	D821JK 無齒牙 Without knurl	D802JK 有齒牙 With knurl
縫製規格 Application code	S	F	F	H/W
手指保護器 Finger guard				
備註 Remark	(S)規格機頭上標準配備 Installed on machine head		(F)規格機頭上標準配備 Installed on machine head	
				選購品 Option

NO.	5	6	7	8	9
壓腳 Work clamp foot	P804JK-A		P805JK-A(組件) P805JK-A(asm.)	P806JK-A(組件) P806JK-A(asm.)	
壓腳下板 Feed plate	D804JK 有齒牙 With knurl	D814JK 有齒牙 With knurl	D832JK 有齒牙 With knurl	D838JK 無齒牙 Without knurl	D816JK 無齒牙 Without knurl
縫製規格 Application code	S	H/W	S	F	F
手指保護器 Finger guard	BF867JK		-	BF897JK	
備註 Remark	(S)規格機頭上標準配備 Installed on machine head	(H/W)規格機頭上標準配備 Installed on machine head	選購品 Option	(F)規格機頭上標準配備 Installed on machine head	

*更換壓腳時，請安裝適合壓腳的手指保護器

*Install a Finger guard suitable for each work clamp foot when replacing the work clamp foot.

選購件一覽表

TABLE OF THE WORK CLAMP FOOT

零件名稱 Part name	說明 Description	貨號 Part No.	
布壓腳下板夾 Feed plate blank  t=1.2 *不銹鋼 t=0.5 *stainless steel t=0.5	無牙齒/有表面處理 Without knurl / with plating	縫製範圍 縱20X橫40 Sewing area 20X40	D818JK
	有牙齒/有表面處理 With knurl / with plating	縫製範圍 縱 20X橫40 Sewing area 20X40	D819JK
	無牙齒/不銹鋼 Without knurl / stainless steel	縫製範圍 縱 20X橫40 Sewing area 20X40	D820JK
	有牙齒/有表面處理 With knurl / with plating	縫製範圍 縱 30X橫40 Sewing area 30X40	D839JK
	有牙齒/有表面處理 With knurl / with plating	縫製範圍 縱 30X橫40 Sewing area 30X40	D822JK
壓腳滑板 Work clamp foot face plate 	布壓腳夾用滑板(右) Face plate for presser blank(right)		P814RJK-E
	布壓腳夾用滑板(組件) Face plate for presser blank(asm.)		P814JK-A
	布壓腳夾用滑板(左) Face plate for presser blank(left)		P814LJK-E
壓腳夾 Presser blank  t=3.2	有牙齒/有表面處理(右) With knurl / with plating (right)	縫製範圍 縱20X橫40 Sewing area 20X40	D835RJK
	有牙齒/有表面處理(左) With knurl / with plating (left)	縫製範圍 縱20X橫40 Sewing area 20X40	D835LJK
	有牙齒/有表面處理(右) With knurl / with plating (right)	縫製範圍 縱30X橫40 Sewing area 30X40	D836RJK
	有牙齒/有表面處理(左) With knurl / with plating (left)	縫製範圍 縱30X橫40 Sewing area 30X40	D836LJK
	有牙齒/無表面處理(右) With knurl / without plating (right)	縫製範圍 縱30X橫40 Sewing area 30X40	D837RJK
	有牙齒/無表面處理(左) With knurl / without plating(left)	縫製範圍 縱30X橫40 Sewing area 30X40	D837LJK
針孔導向器 Needle hole guide 	A=2.3 B=4.0 無槽 A=2.3 B=4.0 Without relief slit	H.W規格 H and W types	E152JK
手指保護器 Finger guard 	A=59 B=74	大擺動用 For large size bartacking	BF867JK

標準花樣一覽表

TABLE OF THE STANDARD PATTERNS

	圈號 No.	落針圖 Stitch diagram	針數 Number of stitches	縫製尺寸 Sewing size (mm)		(註二) 壓腳編號 (Note 2) No. of Work clamp foot
				縱 Length- wise	橫 Cross- wise	
大加固 Large size bartacking	1		42	2.0	16	1
	2					2
	3*					3
	4*		28	2.0	10	1
	5					2
	6					3
	7		36	2.0	10	1
	8*					2
	9*					3
	10*		56	3.0	24	6
		7				
		6				
小加固 Small size bartacking	11		21	2.5	6	8
	12		28	2.5	6	
	13		36	2.5	6	
針織加固 Knit goods bartacking	14		14	2.0	8	5
	15		21	2.0	8	
	16		28	2.0	8	

	圈號 No.	落針圖 Stitch diagram	針數 Number of stitches	縫製尺寸 Sewing size (mm)		(註二) 壓腳編號 (Note 2) No. of Work clamp foot
				縱 Length- wise	橫 Cross- wise	
線加固 Straight line bartacking	17		28	0	10	1
	18					2
	19					3
	20		41	0	25	6
	21					7
	22					6
	縱線加固 Lengthwise bartacking	23		28	20	4.0
24			9			
25			36	20	4.0	9
26						10
27			42	20	4.0	9
針織加固 Lengthwise linear bartacking	28		21	10	0	9
	29					10
	30		28	20	0	9
						10

- 1.縫製尺寸為放大率100%的尺寸
- 2.壓腳號碼請參照壓腳附件一覽表
- 3.NO.22為加工半成品時使用
- 4.* 標記圖案為牛仔布料用

- 1.Sewing size shows the dimensions when the scale rate is 100%
- 2.Refer the No. of work clamp foot to the separate table of work clamp foot.
- 3.For No.22 modify the work clamp foot blank for use.
4. Use the patterns with * marks for sewing denim.

	圈號 No.	落針圖 Stitch diagram	針數 Number of stitches	縫製尺寸 Sewing size (mm)		(註二) 壓腳編號 (Note 2) No. of Work clamp foot
				縱 Length- wise	橫 Cross- wise	
半月形加固 Semilunar bartacking	31		52	7	10	13
	32		63	7	12	13
	33		24	6	10	13
	32		31	6	12	13
	35		48	10	7	14
	36		48	10	7	14
大加固 Large size bartacking	37		90	3	24	6 7
針織加固 Knit goods bartacking	38		28	2	8	5
圓形加固 Round bartacking	39		28	ø12		16
	40		48	ø12		16

	圈號 No.	落針圖 Stitch diagram	針數 Number of stitches	縫製尺寸 Sewing size (mm)		(註二) 壓腳編號 (Note 2) No. of Work clamp foot
				縱 Length- wise	橫 Cross- wise	
縱線加固 Lengthwise bartacking	41		29	20	2.5	12
	42		39	25	2.5	12
	43		45	25	2.5	12
	44		48	30	2.5	12
	45		75	30	2.5	12
	46		42	30	2.5	12
	菊花鎖眼 Radial tacking	47		91	ø8	
48		99		ø8		
49		148		ø8		
50		164		ø8		

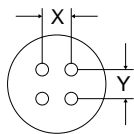

花樣 No.	縫製形狀 Sewing patterns	縫線(根) Sewing thread (PCS.)	標準長度 X(mm)	標準長度 Y(mm)
1, 34		6-6	3.4	3.4
2, 35		8-8		
3		10-10		
4		12-12		
5, 36		6-6		
6, 37		8-8		
7		10-10		
8		12-12		
9, 38		6-6		
10, 39		8-8		
11		10-10	3.4	3.4
12, 40		6-6		
13, 41		8-8		
14		10-10		
15, 42		6-6		
16, 43		8-8		
17		10-10		

花樣 No.	縫製形狀 Sewing patterns	縫線(根) Sewing thread (PCS.)	標準長度 X(mm)	標準長度 Y(mm)
18, 44		6	3.4	0
19, 45		8		
20		10		
21		12		
22		16		
23, 46		6	0	3.4
24		10		
25		12		
26, 47		6-6	3.4	3.4
27		10-10		
28, 48		6-6		
29		10-10	3.0	2.5
30, 49		5-5-5		
31		8-8-8		
32, 50		5-5-5		
33		8-8-8		

1. 標準縫製長度X、Y、為擴大縮小率100%時。
2. 花樣NO.34~NO.50、請在孔小時候(Φ1.5mm以下)使用

1. Standard sewing lengths X and Y given above are given assuming that the scales is 100%
2. Use the patterns No. 34~50 with hole diameter 1.5mm or less.

LKS-1903AN

各鈕扣尺寸的機種區分

MODELS CLASSIFIED BY BUTTON SIZES

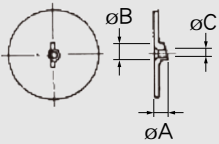
機種名 Model name		LKS-1903AN-301			LKS-1903AN-302	
鈕扣尺寸區分 Button size		極小扣用 For extra-small button		小扣用(附屬品) For small button(accessory)	中扣用 For medium-size button	
可縫制的鈕扣外徑(mm) Outside diameter that can be adjusted(mm)		Φ8~Φ9	Φ9~Φ10	Φ10~Φ15	Φ10~Φ20	Φ10~Φ20
縫製尺寸 Sewing size	縱 Length-wise	0~2.5	0~3.0	0~3.5	0~3.5	0~4.5
	橫 Cross-wise	0~2.5	0~3.0	0~3.5	0~3.5	0~4.5
鈕夾(組合圖) Button clamp jaw lever (combination)		厚度(mm) Thickness (mm)		"1.7 (2.2)"	"1.7 (2.2) (2.7) (0.9)"	"2.0 (2.2) (2.7)"
		型號 Part no.	右 Right	BF916RJK-A1	BF916RJK-A2	BF916RJK-A
			左 Left	BF916LJK-A1	BF916LJK-A2	BF916LJK-A
小針板(mm) Needle hole guide (mm) 		A		1.6	1.6	1.6
		B		Φ2.8	(Φ3.5)	(Φ3.5)
		C		Φ1.6	(Φ1.6)	(Φ2.0)
		型號 Part no.		E155JK	E156JK	E154JK
壓腳下板 Feed plate		D826JK		-	D840JK	

LKS-1903AN

立扣用選購零件

OPTIONAL PART FOR SHANK BUTTON

型號 Part no.	品名 Name of part
BF839JK-A1	夾具套件 Very small clamp Pick-up device complete
BC810JK	針棒 (適用TQ-1) Needle bar(for TQ-1)
BE880JK	撥線器 Wiper asm.
BF929JK	活動板連接件 Moving plate link A
BF930JK	襯套 Bushing
SK955	螺絲(X2) Screw(X2)

型號 Part no.	品名 Name of part
BF928JK	鈕扣座連杆 Button support link
SK360	螺絲 Screw
BF831JK	連桿 Connecting link
SM4844	螺絲 M_screw
E157JK	針板 Needle hole guide
TQX3#14-E	針 NEEDLE TQx3#14-E

4 Needle 6 Thread Feed-off-the-arm Flatseamer

D007RB - 4 52 - 02 - R - T1 / TT

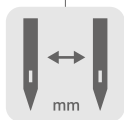

選配件
Attachment

針數
Needle numbers

切刀
Trimmer

01

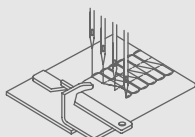

02

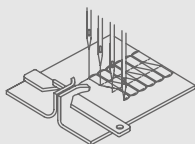

車縫功能
Seaming function

S 褲襠
For panty hose

DS 潛水衣
For diving suit

T1 織帶(女用內衣褲)
For attaching woven tape
(Women's underwear)

T2 貼條(男用內衣褲)
For attaching folded tape
(Men's underwear)

4L10 段差型壓腳針板組
Step type Presser foot and
Needle plate

4L15
4L20 I 1.0, 1.5, 2.0 mm

機種別 Model

D007SB
進階款
Advanced Type

D007S
一般型
General Type

D007SXB
進階款雙差動型
Advanced Dual-differential Type

D007SX
一般款雙差動型
General Dual-differential Type

D007RB
一般型
General Type

特殊規格
Special specification

R 弧狀車縫
Curved seaming

H 厚類車縫(過目、過骨車縫)
Heavy-weight material seaming
(cross seaming of binding / taping or
overlock seam)

AC 布邊防捲曲
Anti-Curl Edge



D007SB | Series D007S | Series

四針六線曲臂式併縫機

4 Needle 6 Thread Feed-off-the-arm Flatseamer



D007SB

D007SB SERIES FEATURES



D007SB / D007S

四針六線曲臂式併縫機

4 Needle 6 Thread Feed-off-the-arm Flatseamer

D007SB為全新的進階款，專為貼身衣物與機能型運動衣的疊併縫所設計，提供即強韌又柔和的車縫效果

All new D007SB realizes the strong and delicate sewing quality for intimate fit wear and high-end sportswear's flat-seaming.

特 点 FEATURE

馬達機體結合一體成形，結構更加穩固，同時降低車體震動

Full range of presser feet fulfills various sewing demands.

精密陶瓷設計線道，過線收線更加順暢，線跡均勻穩定

Delicate threading parts are made of ceramic material, make sewing more smooth and stable.

金屬制自動切吸線設計，替代固定式或活動式

Powerful direct-drive servo motor makes high performance with low energy consuming.

全新密閉式壓腳機構，實現零漏油的目標

Brand new sealed type presser foot mechanism realizes the target of zero oil leakage.

功能齊全的壓具，滿足各種縫製需求

Full range of presser feet fulfills various sewing demands.

全系列搭配直驅伺服馬達，高效節能，動力充沛

Powerful direct-drive servo motor makes high performance with low energy consuming.

標配自動抬壓腳功能，可選氣動型或電動型

Presser foot lifter is a standard equipment, which pneumatic and electric types are optional.



固定式
Fixed type



活動式
Movable type



D007S SERIES FEATURES



D007S經典原裝款·兼顧品質與高CP值的佔用口碑·可專業應用於貼身衣物與機能型運動衣的縫製工程

Classic D007S combines high quality and cost-performance, is the popular choice for intimate fit wear and high-end sportswear's flat-seaming.



特 点 FEATURE

全新密閉式壓腳機構，實現零漏油的目標

Brand new sealed type presser foot mechanism realizes the target of zero oil leakage.

功能齊全的壓具，滿足各種縫製需求

Full range of presser foots fulfills various sewing demands.

全系列搭配直驅伺服馬達，高效節能，動力充沛

Powerful direct-drive servo motor makes high performance with low energy consuming.

標配自動抬壓腳功能，可選氣動型或電動型

Presser foot lifter is a standard equipment, which pneumatic and electric types are optional.



選購件 OPTIONAL ATTACHMENT

AW1

外接空壓式吸布屑組

External compressor type waste suction set

AK

電眼氣動切線組 (附AW7吸布屑組)

Sensor controlled pneumatic type chain cutter (with AW7 waste suction set)

AW2

吸風馬達式吸布屑組

Suction motor type waste suction set









TT

送帶機 (適用T1規格)

Tape feeding device (For T1 specification)



規格 / SPECIFICATION

DS01	 x								OPTIONAL		
D007SB/S-4□□-01	4	6	4.8/5.2/6.0	1.6 2.5	1:0.7 1:1.5	8	FL X 118GCS (4 PCS)	4200	AT/ET/AW1/AW2/AK		
D007SB/S-4□□-02	4	6	4.8/5.2/6.0						6	AT/ET/AW1/AW2/AK	
D007SB/S-4□□-02R	4	6	4.8/5.2/6.0						6	AT/ET/AW1/AW2/AK	
D007SB/S-4□□-02H	4	6	5.2/6.0						6	AT/ET/AW1/AW2/AK	
D007SB/S-4□□-01-S	4	6	5.2/6.0						8	FLG - 8 (1 PC)	AT/ET/AW1/AW2/AK
D007SB/S-4□□-02-S	4	6	5.2/6.0						6	AT/ET/AW1/AW2/AK	
D007SB/S-4□□-02-T1	4	6	4.8/5.2/6.0						6	AT/ET/AW1/AW2/TT/AK	
D007SB/S-4□□-01-T2	4	6	5.2/6.0						8	AT/ET/AW1/AW2/AK	
D007SB/S-4□□-02-T2	4	6	5.2/6.0						6	AT/ET/AW1/AW2/AK	

Remarks :

FLG - 8 為假針規格，避免車縫薄軟面料之縫份起皺。

FLG - 8 is a retainer for seaming light / soft materials without seam wrinkling.

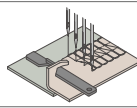
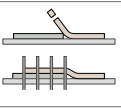
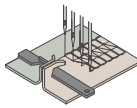
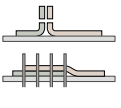
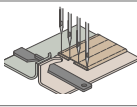
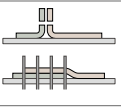
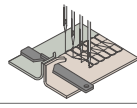
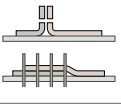
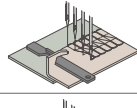
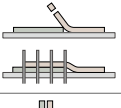
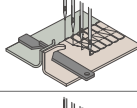
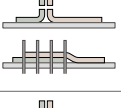
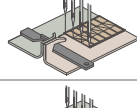
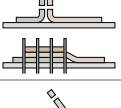
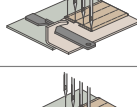
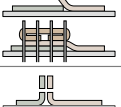
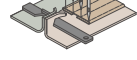
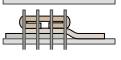
Model	Trimming	Cross-section	Fabric Weight		
			Light	Medium	Heavy
D007SB/S-4□□-01			[Shaded bar]		
D007SB/S-4□□-02			[Shaded bar]		
D007SB/S-4□□-02R			[Shaded bar]		
D007SB/S-4□□-02H				[Shaded bar]	
D007SB/S-4□□-01-S			[Shaded bar]		
D007SB/S-4□□-02-S			[Shaded bar]		
D007SB/S-4□□-02-T1			[Shaded bar]		
D007SB/S-4□□-01-T2			[Shaded bar]		
D007SB/S-4□□-02-T2			[Shaded bar]		

D007RB SERIES FEATURES



新型後切刀

以電磁閥驅動，橫向連杆增加彈簧設計，調整更方便

New chain cutter

Solenoid type cutter with new design mechanism, which make the connecting rod adjustable easily by the spring.



新型潤滑設計

壓腳棒封閉機構設計，並有強制供油回油，前蓋密封且採用倒回流設計，確保零漏油

New Lubrication Design

Sealed type presser foot mechanism with active oil supply and return, and the front cover is sealed without opening realize zero oil leakage.



雙護針機構

專利雙護針設計 (類似三針車的行程)，更穩定控制高速車縫線跡，且較不易斷線

Dual-Needle Guard Mechanism

Patented dual-needle guards (similar to interlock's stroke) make high speed sewing stable and reduce the problem of needle or thread breaking.



高速車縫的穩定度再提升

新型直驅傳動設計，主軸結合馬達轉子，直接傳動不需連軸器配合零件精度的提升，高速車縫更穩定

High Speed Sewing's Stability is Upgraded

New direct-drive design, which the rotor is fixed in the main shaft without connector, is more directly for power delivery. Moreover, spare parts accuracy is upgraded to make a more stable high speed sewing.



全系列併縫上下布邊皆可四針包到位

特殊機構設計，適用不同面料，可達到上下布邊皆可四針包到位之縫製需求

Fully Coverstitching For All Lapseamer Series

Unique mechanism design to deal with wide range fabrics fulfills the sewing request for top and bottom plies lapseaming, going fully to both left and right edge of the stitch.



全新專利隱藏式抬壓具機構

巧妙將抬壓腳電磁閥考量配重藏入機座，節省風力及氣動配件；整機輕量化，避震安靜，外型簡潔；省時省力，提高產能

Patented Electric Presser Foot Lifter Mechanism

The Solenoid smartly concealed in holding base, saving pneumatic volume and accessories, for less weight, anti-vibration, low noise, well balanced body and tidy looks, resulting in time-saving, labor-saving, and higher productivity.



特殊切布刀設計

採用特殊材質·經鏡面處理·低磨擦係數·鋒利耐用·提高縫製品質

Special Fabric Trimmer Design

Unique fabric trimmer with special material and mirror finish, resulting in frictionless, sharp & durable trimming to enhance sewing quality.



超細筒機構設計

過針部之懸臂周長僅150mm·小筒型之衣物縫製也能得心應手·如童裝之袖子

Minimum Cylinder Design

150mm circumference at the needles allows for sewing small tubular work, such as the sleeves seaming of children's wear.



控線更優異

密封式控線鈕；防止繞線；提高縫製之順暢與穩定·過線件全部為陶瓷材質·超耐磨·更滑順

Better Threading Control

Sealed thread tension control knob design, preventing from exceptional winding, makes sewing more smooth and stable. Threading parts are all with ceramic material, which is super wear-resistant, super smooth.



送具機構防油

送具機構新增刮油窗設計·下座的防油性能好

Feed Dog Mechanism Oil Proof

Feed Dog Mechanism is equipped with oil wiper to upgrade sewing bed portion's oil proof level.



標配LED燈·具有5段亮度調節

Standard equipped LED lights with 5-level brightness adjustment.

附 件 / ATTACHMENT



AW1 外接式吸布屑組 須外接空壓機

The external waste suction set for compressor compatible



AW2 密封式吸布屑組 內含吸風馬達

The sealed waste suction set equipped with suction motor



AW7 外接式吸布屑組 需外接空壓機(搭配AK)

The external waste suction set for compressor compatible (for AK)



AW9L 外接式吸布屑組(厚料) 需外接空壓機

The external waste suction set (heavy material) for compressor compatible



TT 送帶機 僅適用T1機型

Tape feeding device for T1 model only



AK 氣動切線裝置









Pneumatic type chain cutter



EK 電動切線裝置











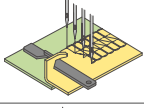
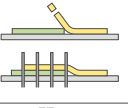

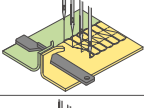
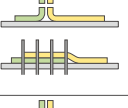

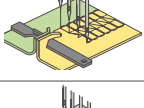
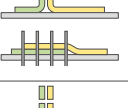

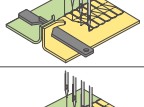
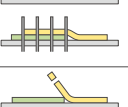

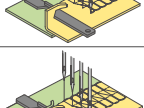
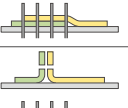

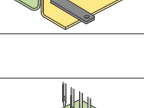
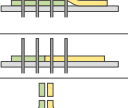
Electronic type thread cutter

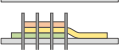
規格/ SPECIFICATION

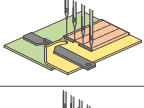
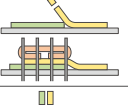
RB01	 x								OPTIONAL	
D007RB-4□□-01 *	4	6	4.8/ 5.2/ 6.0/ 6.4	1.6	1: 0.7 1: 1.5	8	FL X 118GCS (4 PCS)	4200	AW1/AW2/AK	
D007RB-4□□-02 *	4	6	4.8/ 5.2/ 6.0/ 6.4						6	AW1/AW2/AK
D007RB-4□□-02R *	4	6	4.8/ 5.2/ 6.0/ 6.4						6	AW1/AW2/AK
D007RB-4□□-02H	4	6	5.2/ 6.0						6	AW1/AW2/AK
D007RB-4□□-01-S	4	6	5.2/ 6.0	2.5	1: 0.7 1: 1.5	8	FLG - 8 (1 PC)	4200	AW1/AW2/AK	
D007RB-4□□-02-S	4	6	5.2/ 6.0						6	AW1/AW2/AK
D007RB-4□□-01-DS	4	6	5.2/ 6.0						8	AW1/AW2/AK
D007RB-4□□-02-T1	4	6	4.8/ 5.2/ 6.0						6	AW1/AW2/TT/AK
D007RB-4□□-01-T2	4	6	5.2/ 6.0						8	AW1/AW2/AK
D007RB-4□□-02-T2	4	6	5.2/ 6.0						6	AW1/AW2/AK

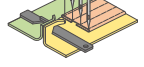
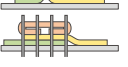
Remarks :

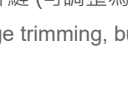
- 標示 * 的型號也供應552機型(5針7線5.2針距)。
 - 552機型具特殊針規·主適用於Spandex面料之縫製·採購此款機針時請徑洽SiRUBA代理商以符合原廠規格。
 - FLG - 8為假針規格·避免車縫薄軟面料之縫份起皺。
- The model with * mark is available for 552 model (5 needle 7 thread 5.2 needle gauge).
 - 552 model with special needle shank spec is mainly designed for Spandex fabrics. While purchasing the needles of 552, please directly contact Siruba to meet original spec.
 - FLG - 8 is a retainer for seaming light / soft materials without seam wrinkling.

Model	Trimming	Cross-section	Fabric Weight		
			Light	Medium	Heavy
D007RB-4□□-01					
D007RB-4□□-02					
D007RB-4□□-02R					
D007RB-4□□-02H					
D007RB-4□□-01-S					
D007RB-4□□-02-S					
D007RB-4□□-01-DS *					
D007RB-4□□-02-T1					
D007RB-4□□-01-T2					
D007RB-4□□-02-T2					

「*」DS model : 潛水衣規格·出廠標準為無切布之接併縫(可調整為單切疊併縫)

「*」DS model : Diving suit sewing's standard is non-edge trimming, butt seam (One side edge trimming lap seam is adjustable.)

D007R SERIES FEATURES



可對應如潛水衣等厚料的四針六線縫縫機

4 needle 6 thread flatseamer perfectly applied for heavy material like diving suit.



經過改良的密封式過線機構可防止繞線並讓過線更為滑順

Shorter distance from thread stand to sewing machine, better thread supply and tension release.



專門針對潛水衣縫製牢固性的四針雙勾針機構

Mechanism of 4 needle 2 looper provides firm and solid stitch diving suit need.



全新專利隱藏式抬壓具機構，將抬壓腳電磁閥考量配重藏入機座，整機輕量化，避震安靜

Patented electric presser foot lifter mechanism concealed in holding base, contributes to less weight, anti-vibration, and low noise.



複合式送料機構讓上送拉輪與貼條連帶動作，一次性的車縫大幅提升生產效率。

Feeding mechanism combines top driving ear puller and tape feeding to complete sewing in one operation.



專利設計提供大型操作空間



Patented design provides larger operation space.

規格/ SPECIFICATION

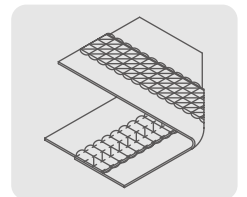
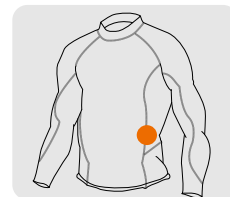

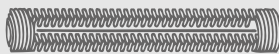

D007R-410	✂ x	👤	→ ←	mm	mm	mm	S.P.M. (Max)
D007R-410-33	4	6	3.3/ 3.3/ 3.3	2.1	10	33	3000
D007R-410-50	4	6	2.5/ 5.0/ 2.5	4.2	10	33	



High-speed 1-needle lockstitch buttonholing machine

BH780	-	C	V
機種 Model BH780 高速機械式鎖眼機 High-speed lockstitch buttonholing machine		壓具尺寸 Work clamp check size A: 30mm X 5.6mm B: 40mm X 6.6mm C: 46mm X 6.6mm D: 53mm X 6.6mm	縫紉形式 Type of stitching non: 標準型 Standard (purl stitching)  v : 毛衣用蕊線雙縫 Double whip stitching with gimp (sweater only) 

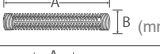
規格 / SPECIFICATION

BH04	BH780-A BH780J-A	BH780-B BH780J-B	BH780-C BH780J-C	BH780-D BH780J-D	BH780-CV	BH780-DV
 Needle No. DPX5	#11~#14	#11~#14	#11~#14	#11~#14	#11~#14	#11~#14
 mm	12	12	12	12	12	12
 S.P.M. (Max)	3600	3600	3600	3600	3600	3600
 A B (mm)	A:9.4~22 B:2.5~4	A:9.4~33 B:2.5~5	A:9.4~40 B:2.5~5	A:16.5~48 B:2.5~5	A:9.4~40 B:2.5~5	A:16.5~48 B:2.5~5
 A B (mm)	A:30 B:5.6	A:40 B:6.6	A:46 B:6.6	A:53 B:6.6	A:46 B:6.6	A:53 B:6.6
 切刀 Knife	6.35~19.05	6.35~25.4	6.35~31.75	12.7~38.1	6.35~31.75	12.7~38.1
切刀 Knife	後切刀系統 Rear knife system					
梭頭 Hook	DP 型特殊旋轉梭子 (自動供油) DP type special rotary hook (automatically lubricated)					
供油系統 Lubricating System	全自動供油 Fully automatic lubrication					
驅動系統 Driving System	使用單皮帶、二級變換速度、自動停止裝置 One belt is used, two-step speed change, automatic stop-motion system					
安全裝置 Safety Device	緊急停止手把 Equipped with emergency stop handle					

BH780 SERIES FEATURES



高速機械式鎖眼機

High-speed lockstitch buttonholing machine

用於各種針織、棉紡、化纖等之物的鈕孔鎖縫，薄料、中厚料均宜；可縫製平線邊與三角線邊，線邊牢固美觀

Buttonholing for ordinary cloth, Knit, etc. It's suitable for all light and medium weight materials. This machine is capable of forming two different types of stitches, namely whip stitch and oril stitch. the sewn seam is beautiful and firm.

- * 更順暢的提升杆 - 改良後的提升杆能有效減少操作者的施力
- * 工作夾具的提升(12mm)使得厚布料的縫製更容易
- * 可借由支齒輪來設定針數，設定範圍在54到345之間。改良後的鍋爐喉板座，張力釋放凸輪和送具凸輪可完美縫製扣眼
- * 此外，利用可替換的量具來測量改變扣眼的尺寸
- * 特殊設計的設計可做平面或筒狀操作，適用於袖子和口袋等的縫製
- * 安全裝置可避免切刀掉落切斷針線，如果針線在縫製中需切斷時，此安全裝置可避免切刀掉落，如此也可避免過程中損傷布料。縫製後若沒有切斷布料，繼續按壓切刀停止杆，切刀就不會掉落
- * 自動單踏板裝置 - 此新式元件加上了自動裝置，只需要一個踏板操作來啟動或停止扣眼的縫製。透過自動裝置的控制，此工作夾具會自動做上下的移動，相對的，此裝置可允許一個操作者同時使用二台機器
- * Smoother lifting lever--The improved lifting lever which moves smoothly will greatly reduce operator's fatigue.
- * The life of the work clamp check has been greatly increased (12mm) so that heavy-weight materials may be sewn easily.
- * The number of stitches can be set at any value between 54 and 345 simply by changing the spur gears. The improved throat plate base, tension release cam and feed cam will provide still better buttonholing finish.
- * Furthermore, change in the buttonholing size can easily be met by the use of exchangeable gauge.
- * With special design, this machine is available for flat and cylindric operation. It is suitable for sleeve and pocket.
- * Safety device to prevent knife from being dropped in case of needle thread breakage. If the needle thread should break while sewing, this safety device will prevent the knife from being dropped, and therefore chance for damage to workpieces under process is eliminated. When you do not cut the fabric after sewing, keep on pressing the knife stop lever, and the knife will not be dropped.
- * Automatic one-pedal unit--This new unit incorporating an automatic device requires only one pedal operation to start or terminate buttonholing. The work clamp check comes down or goes up automatically through this automatic device developed. Accordingly, this unit may allow one operator to attend to two machines.

PK511 SERIES FEATURES



機械式單線環縫釘釦機

Single thread chain-stitch button attaching machine

適用縫製雙孔、四孔或按鍵式鈕扣至襯衫、西服衣褲、外套、工作服等，軸承傳動系統，使運轉更平順、無噪音；底部油棉與頂部油池，雙供油系統設計

Suitable to attach flat two holes, four holes, or press buttons onto all kinds of shirts, overcoats, work uniforms etc. Bearing driving system provides smoother and quieter running. Double (top and bottom) oil feeding design,

鈕扣樣式 / TYPES OF BUTTON



U



U



C



M



W



W

規格 / SPECIFICATION

PK01	X	Needle No. TQX1	mm	A B mm	mm	Auto Trimming	S.P.M. (Max)	REMARK
PK511 PK511J	8, 16, 32	#14~#16	9Φ~27Φ	A: 2.5~6.5 B: 0~6.5	14	-	1500	一般型 General stitching
PK511-U PK511J-U	8, 16, 32	#14~#16	9Φ~27Φ	A: 2.5~6.5 B: 0~6.5	14	√	1500	一般型 General stitching
PK511-C PK511J-C	8, 16, 32	#14~#16	9Φ~27Φ	A: 2.5~6.5 B: 0~6.5	14	√	1500	十字縫 Cross stitching
PK511-M PK511J-M	8, 16, 32	#14~#16	9Φ~27Φ	A: 2.5~6.5 B: 0~6.5	14	√	1500	商標縫 Square mark stitching
PK511-W PK511J-W	8, 16, 32	#14~#16	9Φ~27Φ	A: 2.5~6.5 B: 0~6.5	14	√	1500	立釦縫 Warp-around stitching
PK511-S PK511J-S	6, 12, 24	#14~#16	9Φ~27Φ	A: 2.5~6.5 B: 0~6.5	14	√	1500	襪子縫 Socks stitching

PK522 SERIES FEATURES



高速機械式平縫套結機

High-speed lockstitch bar-tacking machine

- * 最高縫速2,000針/分鐘，可提高縫製效率
- * 大幅度減少踏板的壓力，可減輕操作者的疲勞
- * 更寬廣的縫製空間，且壓腳提升量最大可達17mm，易於縫製物料的置入與取出
- * 可以達成低張力的縫製效果，且切線效果良好，因而實現高品質的縫製作業

- * The maximum sewing speed of 2,000 s.p.m. leads to higher efficiency
- * The great reduction of the pedaling pressure required has been achieved, helping reduce operator fatigue.
- * The expanded sewing space & the work clamp foot lift is as high as 17mm, easy for in and out of the sewing products.
- * The low-tension sewing can be performed & the reliable thread trimming is ensured, leading to further improved seam quality.

規格/ SPECIFICATION

PK02	×	Needle No. DPX5	mm	S.P.M. (Max)	加固縫長度 Length (mm)	加固縫寬度 Width (mm)	圖形 Graph	車縫布料 Sewing Material
PK522-28S	28	#11	17	2000	4-8	1.5	~~~~~	薄布料 Light
PK522-28M	28	#16	17	2000	8-18	2	~~~~~	中厚布料 Medium
PK522-28XL	28	#20	17	2000	8-18	2	~~~~~	特厚布料 Extra Heavy
PK522-36M	36	#16	17	2000	8-18	2-3	~~~~~	中厚布料 Medium
PK522-36XL	36	#20	17	1500	8-18	2-3	~~~~~	特厚布料 Extra Heavy
PK522-42M	42	#16	17	1500	8-18	2-3	~~~~~	中厚布料 Medium
PK522-42XL	42	#20	17	1500	8-18	2-3	~~~~~	特厚布料 Extra Heavy

FA007 SERIES FEATURES





雙針/三針臂式雙線環縫車 (曲腕車)

2/3 Needle feed-off-the-arm double chain-stitch machine

- * 最適合車縫各種不同的布料材質，如夾克、牛仔褲、工作服等，亦可成換成兩針使用
- * 彎針獨立便於調整，針受隨狗齒前後移動，薄或厚皆可適用
- * 本機種可加裝精心設計的拉布輪，雙輪上下全帶動，防皺防滑，縫製出平滑完整的衣物

- * It is suitable for sewing various fabrics such as jacket, jeans, working uniforms. It can also be changed into 2-needle for using.
- * Independent looper makes it easier for adjustment, needle quard move by feed dog to stitch light or heavy materials.
- * The special design of cloth puller, moving twin puller will prevent sloping and crinkle and makes the perfect stitch quality.

規格/ SPECIFICATION

FA1	✕	↔	 mm	Needle No.		 S.P.M. (Max)	車縫布料 Sewing Material
FA007-232	2	3.2	1.4-4.2	TV X7#14	-	3600	薄/中厚布料 Light/ Medium
FA007-248	2	4.8	1.4-4.2	TV X7#14	-	3600	薄/中厚布料 Light/ Medium
FA007-264	2	6.4	1.4-4.2	TV X7#14	-	3600	薄/中厚布料 Light/ Medium
FA007-232/DP	2	3.2	1.4-4.2	TV X7#14	2	3600	薄/中厚布料 Light/ Medium
FA007-248/DP	2	4.8	1.4-4.2	TV X7#14	2	3600	薄/中厚布料 Light/ Medium
FA007-264/DP	2	6.4	1.4-4.2	TV X7#14	2	3600	薄/中厚布料 Light/ Medium
FA007-364M	3	6.4	1.4-4.2	TV X5#18	-	3600	中厚布料 Medium
FA007-364XL/SP	3	6.4	1.4-4.2	TV X5#22	1	3600	特厚布料 Extra Heavy
FA007-396XL/SP	3	9.6	1.4-4.2	TV X5#22	1	3600	特厚布料 Extra Heavy
FA007-364M/DP	3	6.4	1.4-4.2	TV X5#18	2	3600	中厚布料 Medium
FA007-364XL/DP	3	6.4	1.4-4.2	TV X5#18	2	3600	特厚布料 Extra Heavy

High speed one needle Zig-Zag stitching machine

LZ457A

140

L

43P4

機種別 Model

曲折縫縫紉機
High speed one needle Zig-Zag stitching machine

車縫布料 Sewing Material

L 薄布料
Light

M 中厚布料
Medium

輔助件 Device

43P4 : 4針一景
Four stitches form one crinkle.

43P6 : 6針一景
Six stitches form one crinkle.

MDL312 : 送帶寬度2" (50mm)
Feeding width: 2"(50mm)

MDL314 : 送帶寬度4" (100mm)
Feeding width: 4"(100mm)

表示功能或用途 Function or Purpose

20 可做蕾絲鑲邊及一般人字形縫紉
General zig-zag work and lace attaching.

21 可縫蕾絲花邊及肩帶之縫製
Lace and shoulder strap attaching.

40 可做緊身衣物和胸衣之鬆緊帶縫製及裝飾縫製之功能
Attach elastic straps to corsets and bras and making decorative sewing.

140 漁網狀3針4點人字形
Fishnet type three stitches four points zigzag sewing type.

143N 萬能車
Universal sewing

LZ SERIES FEATURES



漁網車 Fishnet Type

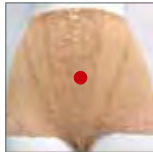

Fishnet

LZ1388-5/140L

漁網狀3針4點人字形，適用於束褲、束腹、塑身衣褲、護腰、醫療及運動器材...

Fishnet type three stitches four points zigzag sewing type. Suitable for corsets, fitting clothes, waist protection clothes, medical and fitness equipment, etc.

貝殼型車 Shell Type

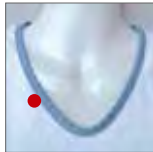

six stitches
one crinkle

LZ457A-143N-L-43P4

貝殼形線跡滾領推景器可選擇4針一景或6針一景，以鎖式線跡牢固地縫製出漂亮的荷葉邊，最適合婦女的背心式襯衣、睡衣、無領衫及針織衣物的領口、袖口或肩帶

Shell type stitches piping collar pleating device. Four stitches one crinkle or six stitches one crinkle. Tightly sewing a perfect rickrack with the zigzag stitches, suitable for corsets, camisoles, bed gowns, collarless shirts, and collar, cuff or shoulder strap of knitting clothes.

萬用車 Universal Type











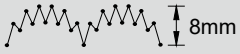

專利萬用可換花盤
Patented Universal
Decorative Cam

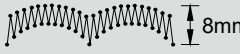
LZ457A-143N-L

可作裝飾縫製，新式流行女用緊身內衣褲及襯衫之縫紉。配合線跡需要而備有多種花樣凸輪供更換

Decorative sewing, new type fashion feminine underwear and shirts. Multiple decorative type cam for changing based on needs.

花盤(凸輪)選購表(Optional Cams)

12針跡開式扇形花盤 NP-6358 12-stitch opened scallop cam	24針跡新月扇形花盤 NP-6360 24-stitch crescent scallop cam	24針跡勻稱扇形花盤 NP-6464 24-stitch even scallop cam	24針跡勻稱扇形花盤 NP-6295 24-stitch even scallop cam
 8mm	 8mm	 8mm	 8mm
4針跡盲縫花盤 NP-6396 Blind stitch cam (4 stitches)	6針跡盲縫花盤 NP-6364 Blind stitch cam (6 stitches)	8針跡盲縫花盤 NP-6480 Blind stitch cam (8 stitches)	12針跡盲縫花盤 NP-6482 Blind stitch cam (12 stitches)
 5mm	 5mm	 5mm	 5mm
普通Z字形花盤 NP-6394 1-step Zig Zag cam	2針3點Z字形花盤 NP-6462 2-step Zig Zag cam	3針4點Z字形花盤 NP-6362 3-step Zig Zag cam	
 5mm	 8mm	 8mm	

規格/ SPECIFICATION

LZ1		S.P.M.(Max)	用途 Applications	圖形 Graph
LZ457A-105L	8.0mm (5/16")	1.3mm (20spi)	5000 可做蕾絲鑲邊及一般人字形之縫紉 Attaching lace and making general herringbone sewing.	
LZ457A-125L	5.0mm (13/64")	2.0mm (13spi)	5000 可做蕾絲花邊及肩帶縫製等等 Attaching lace, making shoulder straps etc.	
LZ457A-135L	8.0mm (5/16")	1.3mm (20spi)	5000 可做緊身衣物或胸衣之鬆緊帶縫製 Elastic seaming and attaching for corsets or bras.	
LZ457A-143N-L (Universal Type)	8.0mm (5/16")	1.3mm	3400 裝飾縫製配合線跡需要而備有各種花樣凸輪供更換 (5.0mm凸輪隨車附於配件盒裡) Decorative sewing, multiple decorative type cam for changing based on needs. (The 5.0mm cam is attached inside the accessory box with each product.)	
	5.0mm (13/64")	2.0mm		
LZ1388-5/140L	8.0mm	6.5mm	4000 漁網狀3針4點人字形。 Fishnet type three stitches four points zigzag sewing type.	
LZ1388-5/140M	8.0mm	6.5mm	4000	
LZ457A-143N-L-43P4	5.0mm	-	3400 貝殼形線跡滾領4針一景 Shell type stitches piping collar pleating device. Four stitches one crinkle	
LZ457A-143N-L-43P6	5.0mm	-	3400 貝殼形線跡滾領6針一景 Shell type stitches piping collar pleating device. Six stitches one crinkle.	

輔助件/ ATTACHMENT



- 43P4 推景器(限143N機型)**
43P6 43P4:4針一景
43P6:6針一景
Pleating device (143N model only)
 four stitches form one crinkle.
 six stitches form one crinkle.



- MDL312 機械式鬆緊帶調節裝置**
MDL314 MDL312:送帶寬度2" (50mm)
 MDL314:送帶寬度4" (100mm)
Mechanical metering device for elastic tape
 Feeding width: 2"(50mm)
 Feeding width: 4"(100mm)

L380/ DL380 SERIES

CHAINSTITCH SEWING MACHINE



L	38	2	R	H	-	32	P																						
機種別 Model		針向 Needle array					後拖輪 Rear puller																						
L 一般型 Normal type		- 橫列 Parallel					- 無 None																						
DL 直驅型 Direct-drive type		R 縱列 Tandem					P 塑膠拖輪 Plastic puller																						
							I 鐵制拖輪 Iron Puller																						
針數 Number of needles		車縫布料 Sewing fabric		<table border="1"> <thead> <tr> <th>No.</th> <th>mm</th> <th>inch</th> </tr> </thead> <tbody> <tr> <td>32</td> <td>3.2</td> <td>1/8"</td> </tr> <tr> <td>48</td> <td>4.8</td> <td>3/16"</td> </tr> <tr> <td>64</td> <td>6.4</td> <td>1/4"</td> </tr> <tr> <td>79</td> <td>7.9</td> <td>5/16"</td> </tr> <tr> <td>95</td> <td>9.5</td> <td>3/8"</td> </tr> <tr> <td>127</td> <td>12.7</td> <td>1/2"</td> </tr> </tbody> </table>			No.	mm	inch	32	3.2	1/8"	48	4.8	3/16"	64	6.4	1/4"	79	7.9	5/16"	95	9.5	3/8"	127	12.7	1/2"		
No.	mm	inch																											
32	3.2	1/8"																											
48	4.8	3/16"																											
64	6.4	1/4"																											
79	7.9	5/16"																											
95	9.5	3/8"																											
127	12.7	1/2"																											
1 單針 Single Needle		- 中厚料 Medium																											
2 雙針 Two Needles		H 厚料 Heavy																											
3 三針 Three Needles																													

規格/ SPECIFICATION

L11		TVx7 #9-21			mm		選配 Option		
							馬達 Motor	後拉輪 Rear Puller	桌板 Table
L381	-	1	2	Min: 1.4 mm Max: 4 mm	手動 Hand lifter 5.5mm	4000	離合器馬達 T32xxHx	-P	L818-T2A
L382-□□	32, 48, 64, 79, 95, 127	2	4				Clutch Motor T32xxHx		
L382R	-	3	6						
L383-64	32+32	3	6		膝動 Knee lifter 10mm	4000	標配直驅馬達 Built-in Direct-drive Motor	-P	L818-T2A
DL381	-	1	2						
DL382-□□	32, 48, 64, 79, 95, 127	2	4						
DL382R	-	3	6						
DL383-64	32+32	3	6						

AA FEATURES



手提式縫袋口機(附加潤滑油裝置)





手提操作，輕便快捷，每台約 5 公斤。自動切線及壓具提升裝置，塑膠握把附皮帶護蓋，可加裝掛勾裝置，節省人力，機構優良附加潤滑油裝置，經久耐用。適宜縫合各類紙袋、麵粉袋、塑膠編織袋、麻袋及其他袋類之袋口縫合或布頭接合染整



portable bag closer(with lubricating device)

Light weight, easy operation with automatic thread cutter and presser foot lifter. Equipped with lubricating device for oiling and prolonging machine life. For closing all kinds of paper, cotton, PP/PE and gunny bags for packing feeds, seed, fertilizer, flour, chemical powder etc. Also available for closing textile end-join before dyeing.

規格/ SPECIFICATION

A1	 X		 mm	 Needle No.	 S.P.M. (Max)
AA-6	1	1	7.2	D5	1700



Архангельск (8182)63-90-72
Астана (7172)727-132
Астрахань (8512)99-46-04
Барнаул (3852)73-04-60
Белгород (4722)40-23-64
Брянск (4832)59-03-52
Владивосток (423)249-28-31
Волгоград (844)278-03-48
Вологда (8172)26-41-59
Воронеж (473)204-51-73
Екатеринбург (343)384-55-89
Иваново (4932)77-34-06

Ижевск (3412)26-03-58
Иркутск (395)279-98-46
Казань (843)206-01-48
Калининград (4012)72-03-81
Калуга (4842)92-23-67
Кемерово (3842)65-04-62
Киров (8332)68-02-04
Краснодар (861)203-40-90
Красноярск (391)204-63-61
Курск (4712)77-13-04
Липецк (4742)52-20-81

Киргизия (996)312-96-26-47

Магнитогорск (3519)55-03-13
Москва (495)268-04-70
Мурманск (8152)59-64-93
Набережные Челны (8552)20-53-41
Нижний Новгород (831)429-08-12
Новокузнецк (3843)20-46-81
Новосибирск (383)227-86-73
Омск (3812)21-46-40
Орел (4862)44-53-42
Оренбург (3532)37-68-04
Пенза (8412)22-31-16

Россия (495)268-04-70

Пермь (342)205-81-47
Ростов-на-Дону (863)308-18-15
Рязань (4912)46-61-64
Самара (846)206-03-16
Санкт-Петербург (812)309-46-40
Саратов (845)249-38-78
Севастополь (8692)22-31-93
Симферополь (3652)67-13-56
Смоленск (4812)29-41-54
Сочи (862)225-72-31
Ставрополь (8652)20-65-13

Казахстан (772)734-952-31

Сургут (3462)77-98-35
Тверь (4822)63-31-35
Томск (3822)98-41-53
Тула (4872)74-02-29
Тюмень (3452)66-21-18
Ульяновск (8422)24-23-59
Уфа (347)229-48-12
Хабаровск (4212)92-98-04
Челябинск (351)202-03-61
Череповец (8202)49-02-64
Ярославль (4852)69-52-93